

HEADERS J1, J2, J5 & J6: ALLOW ALL ARDUINO PINS TO BE EASILY REASSIGNED.

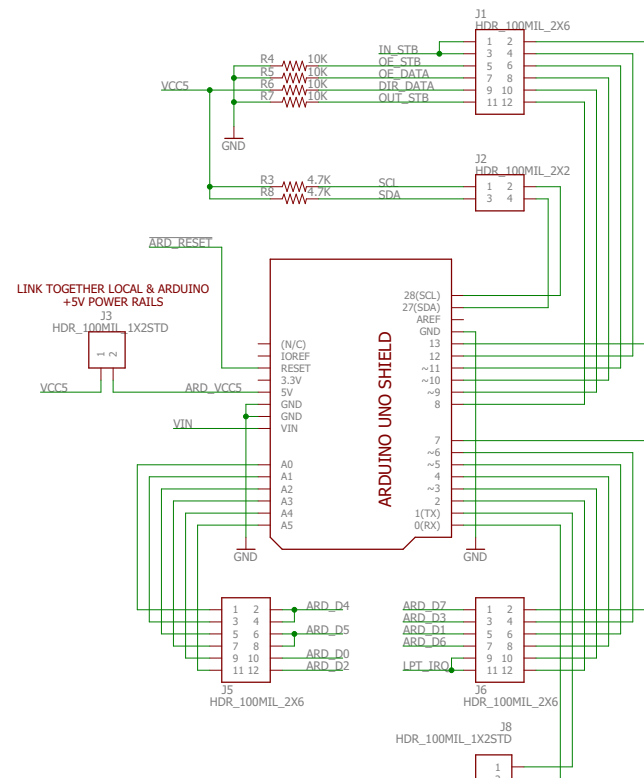

SET BASE I2C-ADDRESS FOR PCA9535 GPIO-EXPANDERS

J7: 3-4 (A2)	J7: 1-2 (A1)	(8-bit) Base Address U7	(7-bit) Base Address U9
IN	IN	0x40	0x42
IN	OUT	0x44	0x46
OUT	IN	0x48	0x4A
(DEFAULT) OUT	OUT	0x4C	0x4E
			0x20
			0x21
			0x22
			0x23
			0x24
			0x25
			0x26
			0x27

