

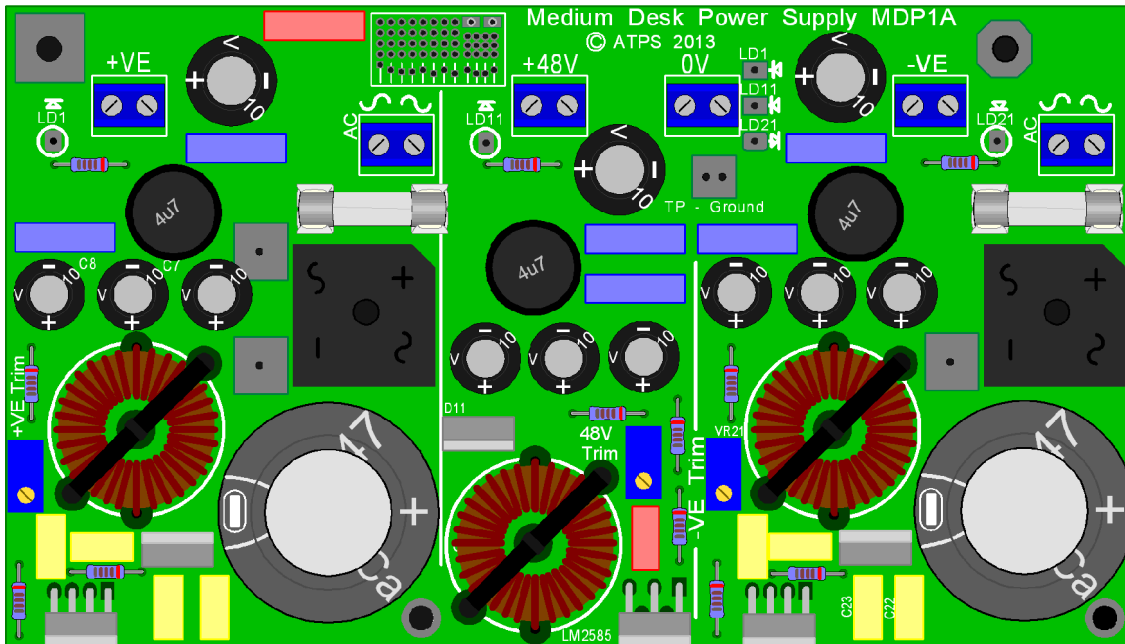

Australian Technical Production Services

Medium Desk Supply



Copyright notice.

These notes, the design, schematics and diagrams are Copyright © Richard Freeman, 2013

While I am happy for the notes to be printed and copied for personal or educational use, they may not be used in any other publication, or published on any other website without written permission.

Further information may be found at www.atps.net

Revision history:

16/09/2013		Start document – Prototype - PCB rev P1A
12/02/2014	pdf-mdpR1A	Production R1A - PCB (Medium Desk PSU 6B.PCB)
16/04/2014	pdf-mdpR1A(b)	Final corrections following build

Credits

This Article contains contributions by:

Richard Freeman

Table of Contents

Medium desk supply	2
Circuit description	2
Powering 51x Racks	4
Transformer	4
Choosing a Transformer	4
Choosing Input capacitors	5
Heat-sinking requirements	5
Regulators	5
Rectifiers	5
Shielding	5
Grounding	6
Ground lifting	6
Construction	7
Parts locator	7

Assembly	8
Secondary Filter	9
Connecting the Transformer	10
Connecting the LEDs	10
Regulator mounting	10
Parts list	11
Electronics	11
Hardware	11
Inside Template	12

Medium desk supply

While specifications ultimately depend on the Transformer and heat-sinking used, the power supply is capable of delivering:

Rail	Current	
+17V	5 A	Audio Supply
-17V	5 A	Audio Supply
+48V	1 A	Phantom power

Circuit description

This circuit is based around Texas Instruments LM2585 and LM2679 simple switchers regulators, I did consider using linear regulators, but that approach would have ended up generating up to 200W of heat, (or almost as much power as the supply delivers). Using switching regulators dropped power dissipation to a much more manageable 16 Watts.

There are two basic Switchers in use here, IC1 and IC21 act as buck regulators, while IC11 is a boost regulator generating the 48V supply. They are configured to run off a 21- 40 Volt input, so a readily available dual 25 Volt transformer may be used.

Following feedback from the small desk supply project, I elected to make this supply trimmable with a range covering 13-18 Volts which should cover the common supply voltages, typically 15V, 16V and 17V.

Following feedback from the small desk supply project, I elected to make this supply trimmable with a range covering 13-18 Volts which should cover the common supply voltages, typically 15V, 16V and 17V.

Based on experience with a bench supply that had a noisy pot, the wiper arm for the trim-pot is between the feedback line and the shunt to ground, this means that should the contact go open circuit, the regulator will decrease the output voltage to its internal reference, of around 2 Volts.

As the Switchmode integrated circuits used in this supply have a fast rise time, this can result in some ringing on the output with a fundamental above 30-35Mhz (I had recorded 35Mhz for my first prototype, but measured 65Mhz on my final build, so I am not sure if I measured incorrectly the first time, and as the Prototype is now in studio in Melbourne, I am not in a position to easily remeasure this).

I did consider and test an alternative circuit with a slower rise time, however this increased power dissipation (although in the scheme of things this was not significant), circuit complexity and the size of the PCB.

As this ringing was well above Audio frequencies, I decided a more complex design was not worth the extra effort and added secondary filters of L2, C101, C102 etc. which largely deal with this noise.

Having said this however, I strongly recommend the power supply is mounted in an earthed metal box and ferrites placed on any input and output leads.

As this is intended as an external supply I would expect this to be mounted in a metal case anyway, but it is worth mentioning here.

I chose the LM2679 over the LM2678 as it has soft start capability, so it should be able to start with a highly capacitive load. Having said this though, tests with the LM2678 found that it started happily even with 15,00uF across it, while the LM2679 started under full load and 33,000uF.

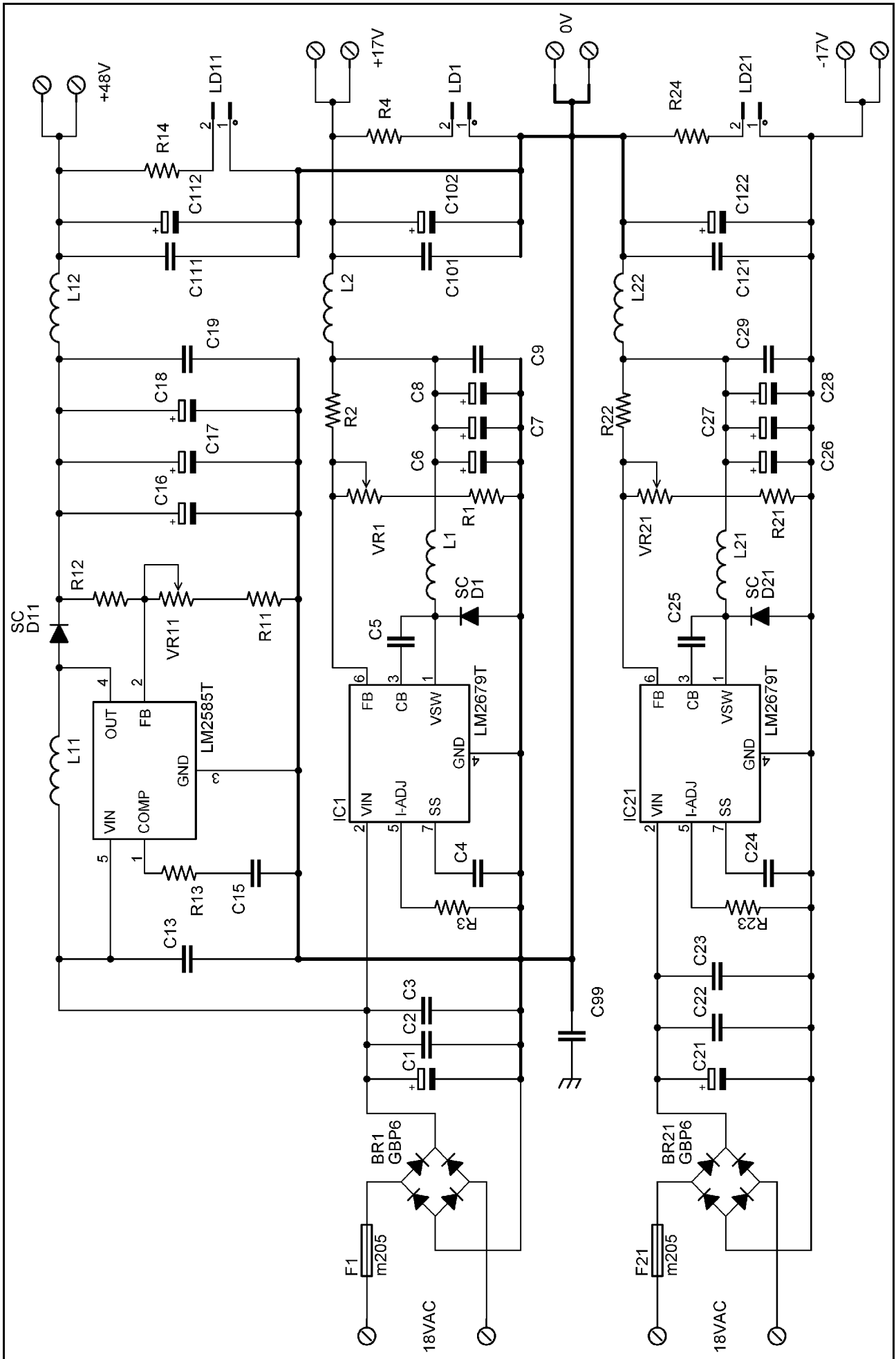

I would not expect that any mixing consoles would have any issues with the soft-start, however I have not tested every desk out there, so it may be safer to assemble the power supply with soft-start disabled (this is done by leaving off C4 and C24) and only fitting them if soft-start is required (i.e. if the power supply struggles to start under load).

Powering 51x Racks

If you wish to use this power supply for powering 51x style racks then you will need 2 x PCBes, one for the +/-16V and 48V supplies and the second to deliver the +/-24V rails.

The power supply may be readily modified for +/- 24V output by using the 25v transformer option and increasing the value of R2 and R22 to 15K

5 Amps per rail is overkill for a 51x rack (which specifies 130mA per slot) so you may also wish to drop the current limit to say 3 Amps and use two 160Va toroidal transformers instead.

Current limit can be reduced by increasing the value of R3 and R23 as these set the peak current limit for the regulator. As this sets Peak, rather than DC current we need to allow about 50% over steady state current, so for 5 Amps The peak current output may be calculated using the formula $37125 / R3$ so to drop current limit to 3 Amps (4.5A peak) use an 8K2 resistor for R3 and R23.

Transformer

This project requires a dual wound 25v Transformer capable of delivering at least 5 Amps. 300VA 25V Toroidal Transformers are readily available which are ideal for this project any Transformer with dual windings between 18 and 27 Volts with power rating of over 225VA should do the job

Frame ground terminal on the PCB also ties noise suppression capacitor C99 to ground and should have enough room for a spade lug so it can be used for mains ground distribution.

If you use a toroidal transformer I strongly recommend that the Power supply ground is connected to mains ground at some point (see also section on Grounding) as the construction of toroidal transformers means that they are inadequate for use in double insulated power supplies.

Choosing a Transformer

In Australia AC supply is specified as 230V +10/-6% but is typically between 240 and 250V. a 300VA Toroidal transformer should have regulation of around 6% but lets pessimistically assume 10% (to safely cover any likely variations).

The upper supply limit is set by the regulator, the LM2679 and LM2585 have a maximum input voltage ratings of 40V, so this sets the upper limit ('Absolute maximum' is specified as 45V, so actually there is still some wriggle room here) while ideally the minimum input voltage wants to about 3V higher than the output voltage (again there is some wriggle room here, but it is always best to leave that for unforeseen circumstances than design to absolute limits)

So it depends on what output voltage you want, if you want a 17V output, then the input needs to be between 20 and 40 Volts, while if you want 15V then the input can be between 18V and 40V

Since the positive rail needs the most current (supporting both the +17V regulator and the 48V regulator) it will therefore have the most ripple.

With an 18V transformer and 15,000uF of capacitance my calculations give me between 21.2 and 24V peak. But by the time we allow for power supply variations, Transformer regulation etc. we get a maximum voltage of 29V with a minimum of 20, so that only just fits the required range.

The next commonly available transformer is 25v, and if we used a 10,00uF capacitor instead (as we have a higher secondary voltage we will need a higher voltage rating on the capacitor, so may not be able to fit in a 15,000uF capacitor, but since supply voltage is higher the current draw will be lower, so we can get away with a smaller capacitor) this will give us between 39 and 25 Volts, allowing for Transformer regulation, Mains supply variations etc.

So either an 18V or 25v 300VA toroidal transformer will work fine, however the 25V transformer is the safer selection, so for the sake of this article I will presume a 25v Transformer.

Choosing Input capacitors

Ok so as you may have noticed from above if you run an 18V transformer with a 17V output we need a >15,000uF capacitor for C1 with a voltage rating of greater than 30V. If however you use a 25v Transformer then you can use a >10,000uF capacitor but it will need a voltage rating of at least 40V.

Ripple current is typically about half the DC supply current, so with current draw of around 6Amps (this presumes the 48V supply is fully loaded, which is unlikely) I would aim for a ripple current of greater than 3 Amps.

Generally 105°C rated capacitors will take elevated temperatures better and last longer than 85°C so although we should be going nowhere near that temperature it is worth paying a little extra and getting 105°C capacitors

The final limitation is the size, by all means go as high as you like (presuming it will fit in your case) but the **PCB allows for a 30mm (1.18 inch) diameter capacitor with a pin spacing of 10mm (0.39 inch which appears to be the standard spacing for 'snap fit' style capacitors)** looking at catalogues, there does generally appear to be a reasonable selection available that fits the above requirements.

Note: Capacitors of this rating come in both 35mm (1.4 inch) and 30mm (1.18 inch) diameter varieties, we want the thinner ones).

So to summarise, if you want 17V out:

for an **18V transformer at least 15,000uF at 35V**, with at least 3 Amp ripple current

for a **25v Transformer at least 10,000uF at 40V** with at least 2.5 Amp ripple current

They need to be Snap fit style, **30mm diameter (about 1.18 inch) with lead spacing of 10mm (0.39 inch)**, and for preference (although not mandatory) 105°C rated.

Heat-sinking requirements

Regulators

The two LM2678 Regulators dissipate around 6W each, and the LM2585 around 4W, for a total power dissipation of 16W. As the LM2585 dissipates less power I will base the following calculations on the LM2678.

The LM2678 has a junction to case Thermal resistance of 2°C per watt plus allow another 1°C per watt for a total thermal resistance of 3°C Per watt so at 6W, the junction will be 18°C hotter than the heatsink. The data sheet specifies a maximum junction temperature of 125°C, so the heatsink needs to be less than 107°C. Since a heatsink at that temperature is going to become a major hazard, and the lifespan of other components will be seriously compromised, it is more realistic to aim for a heatsink temperature of no more than 65°C (hot, but will not cause burns or injury except under sustained contact) which in turn will keep the junction at a frosty 83°C.

If we assume an ambient temperature of 40°C maximum, then we will need a heatsink of $(65-40)/18 = 1.4°C$ per watt.

Rectifiers

In my prototype the rectifiers ran hot under full load, and calculations suggested they were dissipating around 7 Watts, so if we again aim at 65°C with an ambient temperature of 40°C then they will need a Heatsink of at least 3.5°C per watt.

The PCB has a hole under the rectifiers for inserting a screw driver to tighten heatsink bolts, or running a long bolt up into the heatsink, see construction notes for more details.

Shielding

As mentioned earlier the fast rise time of the switching transistors can result in this power supply causing RF interference (typically over 30-35 MHz) if care is not taken.

The power supply should be mounted in an earthed metal box and I would suggest that wires going into and out of that box have ferrite beads to for noise suppression, or if you have one available a mains filter on the AC line is a good idea (in this case you would not need to worry about ferrite beads on the AC supply).

The mounting hole near the +VE supply links a suppression capacitor to mains ground so this will need to either be firmly bolted to the chassis using spring washers to ensure a good connection or I suggest mounting a spade lug under this bolt and using this point as your mains earth distribution.

Grounding

As toroidal transformers (as recommended) have the secondary winding wound directly over the top of the Primary winding, they will not be up to double insulation standards so the secondary side will need to be grounded in some way.

So my first recommendation is that the output is grounded with a link between 0V and Mains ground.

Ground lifting

I have seen a potentially deadly system sold for general 'ground breaking' use which use two back to back diodes to break the ground connection while still providing a clamp for any fault scenario. While this system is good in theory, the issue is the amount of current the diodes may be required to handle in a fault condition. In Australia 10 Amp mains circuits typically have breakers of 20 Amps but in some cases may be higher (say a poorly wired 3 phase Distro which may have 45 or 60 Amp breakers) and in the event of an Active to Ground fault, these diodes could have surge currents peaking at hundreds or thousands of amps through them.

While semiconductors will typically fail short, this is not a guaranteed failure mode and also currents of this magnitude are likely to also evaporate the smoking remains of the diode Junction, quickly turning it into an open circuit.

With this project however, we have a controlled environment with an AC mains fuse of around 1.5 Amps* slow blow so at least we have a known fuse in circuit.

One warning here, you should always assume that Active and Neutral may have been swapped, so this means we want two fuses, one in Active and one in Neutral.

As we have used a slow blow fuse to accommodate surge current from the toroidal transformer any ground clamping diodes will need to be able to handle a surge of at least 10 times the fuse rating.

35 Amp bridge rectifiers are readily available (which will handle typical surge currents of 10-20 times of their rated current, or 300-700 Amps) for only a few dollars, so I would suggest using one of these.

If you wish to take this ground lifted approach, connect the AC terminals of the bridge between mains ground and circuit ground, and then short out the +VE and -VE terminals on the Bridge (as per the diagram below).

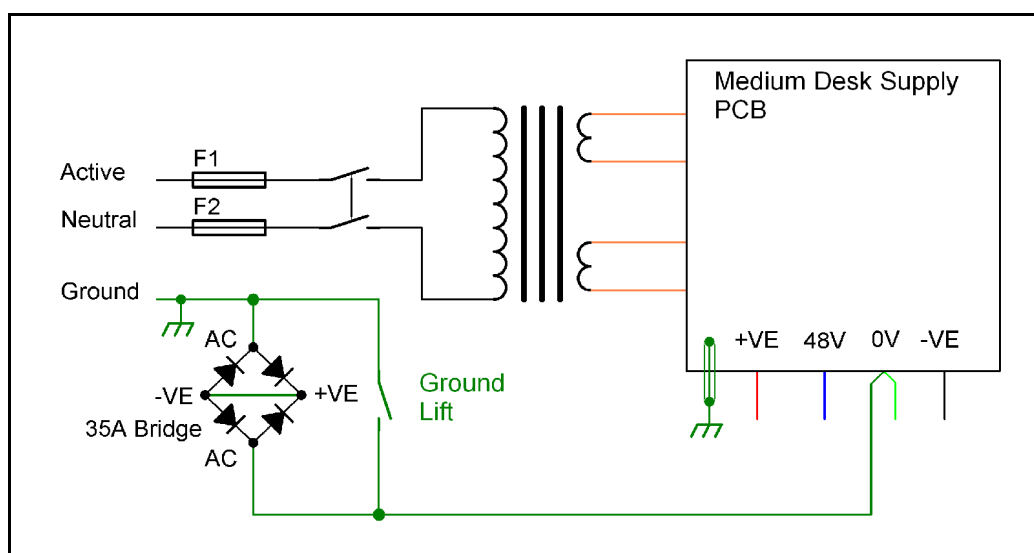

I just want to emphasise as mentioned before, if you adopt this arrangement both Fuse F1 and F2 are absolutely essential for safety.

* This assumes 240V, for 110V you would probably go with a 3.5 Amp fuse with a corresponding fault surge current of 35 Amps, although given the low cost and ready availability of 35 Amp bridges I suggest using them anyway.

Construction

Parts locator

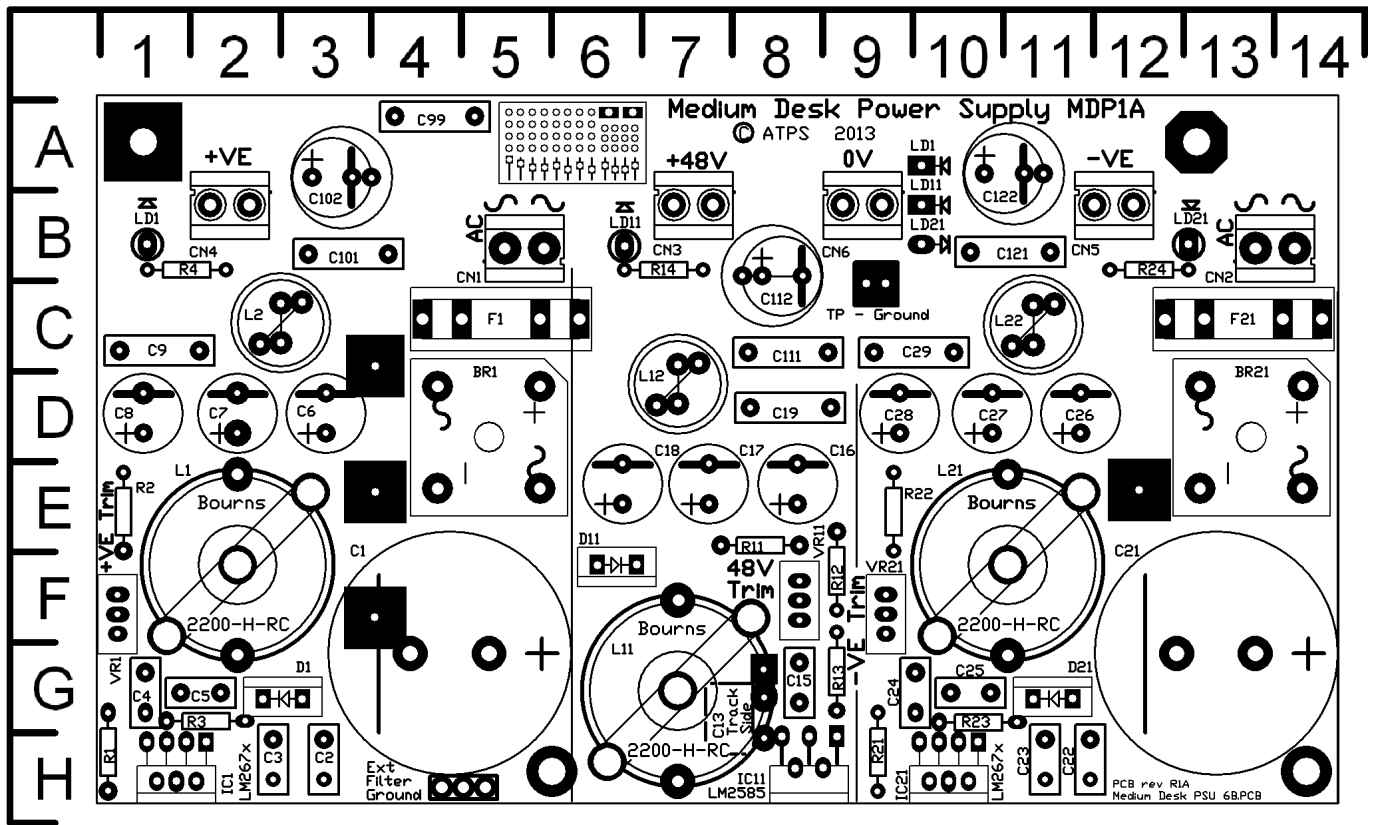

Part	Location	Description	Part	Location	Description
BR1	D-5	10 Amp bridge (MP1004G)	C112	C-8	220uF 63V Low ESR
BR21	D-13	10 Amp bridge (MP1004G)	C121	B-10	470nF 63V Poly
<i>C1</i>	<i>G-4</i>	<i>10,000uF 45V 30mm dia (see "choosing input capacitors")</i>	C122	A-10	470uF 25V Low ESR
C2	H-3	1uF 63V Poly	D1	G-3	MBR1060 Schottky Diode
C3	H-2	1uF 63V Poly	D11	F-6	MBR1060 Schottky Diode
<i>C4</i>	<i>G-1</i>	<i>10nF 50V Poly (soft-start)</i>	D21	G-11	MBR1060 Schottky Diode
C5	G-2	10nF 50V Poly	<i>F1</i>	<i>C-5</i>	<i>6 Amp slow blow m205</i>
C6	D-3	47uF 25V Low ESR	<i>F21</i>	<i>C-13</i>	<i>6 Amp slow blow m205</i>
C7	D-2	47uF 25V Low ESR	IC1	H-1	LM2678T-ADJ
C8	D-1	47uF 25V Low ESR	IC11	H-8	LM2585T-ADJ
C9	C-1	470nF 63V Poly	IC21	H-10	LM2678T-ADJ
C13	G-7 (under)	1uF 63V Poly	L1	F-2	27uH Bourns 2206-H-RC
C15	G-8	150nF 100V Poly	<i>L2</i>	<i>C-2</i>	<i>4.7uH (Link out if not in use)</i>
C16	E-8	68uF 63V Low ESR	L11	G-7	270uH Bourns 2117-H-RC
C17	E-7	68uF 63V Low ESR	<i>L12</i>	<i>D-7</i>	<i>22uH (Link out if not in use)</i>
C18	E-6	68uF 63V Low ESR	L21	F-10	27uH Bourns 2206-H-RC
C19	D-8	470nF 63V Poly	<i>L22</i>	<i>C-11</i>	<i>4.7uH (Link out if not in use)</i>
<i>C21</i>	<i>G-13</i>	<i>10,000uF 45V 30mm dia (see "choosing input capacitors")</i>	R1	H-1	750R 1% Metal film
C22	H-12	1uF 63V Poly	R2	E-1	11K 1% Metal film
C23	H-11	1uF 63V Poly	R3	G-2	5K 1% metal film
<i>C24</i>	<i>G-10</i>	<i>10nF 50V Poly (for soft-start)</i>	R4	B-1	1K 1% Metal film
C25	G-10	10nF 50V Poly	R11	E-8	1K2 1% Metal film
			R12	F-8	56K 1% Metal film
			R13	G-8	3K 1% Metal film

Part	Location	Description	Part	Location	Description
C26	D-11	47uF 25V Low ESR	R14	B-7	3K 1% Metal film
C27	D-10	47uF 25V Low ESR	R21	H-9	750R 1% Metal film
C28	D-9	47uF 25V Low ESR	R22	E-9	11K 1% Metal film
C29	C-9	470nF 63V Poly	R23	G-10	5K 1% metal film
C99	A-4	0u1F 230V Poly	R24	B-12	1K 1% Metal film
<i>C101</i>	<i>B-3</i>	<i>470nF 63V Poly</i>	VR1	F-1	500R 25 turn Vertical trimpot
<i>C102</i>	<i>A-3</i>	<i>470uF 25V Low ESR</i>	VR11	F-8	500R 25 turn Vertical trimpot
<i>C111</i>	<i>C-8</i>	<i>470nF 63V Poly</i>	VR21	F-9	500R 25 turn Vertical trimpot

Assembly

I suggest that you start by mounting the board in your case (or on your bracket), then bolt the TO220 devices in place and solder the outside pins of each device from the top of the PCB (which you can do as it is double sided) note you will need a fine tipped soldering iron to do this (**note** picture is from a different project, but the idea is the same). This will ensure that the devices line up properly, the lead length is correct, and makes life a lot easier when it comes to final assembly.

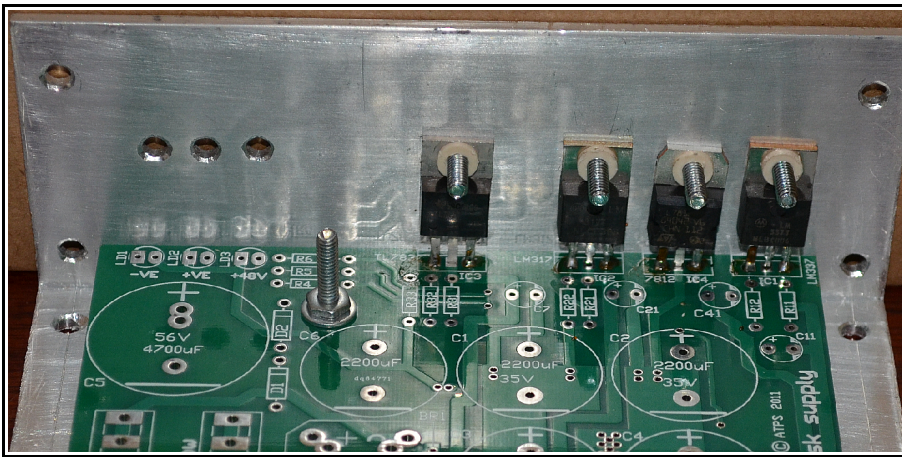

Remove the board from the case and finish assembly by next inserting all the smaller components such as the resistors and smaller capacitors – except for C13, leave C13 until later, also if you are unsure about using soft-start then leave out the soft start capacitors C4 and C24.

Next solder in the Variable resistors, Diodes and fuses. When soldering in the fuse clips it is a good idea to clip in an old M205 fuse before applying solder as this will ensure that you have the fuse clips the right way around and also keeps them clips lined up during soldering.

Now mount the toroidal inductors (L1, L11 and L21) I recommend that these are insulated from the PCB by placing a piece of cardboard (or similar) between the inductor and the PCB to avoid any chance of shorts between the Vias and the inductor.

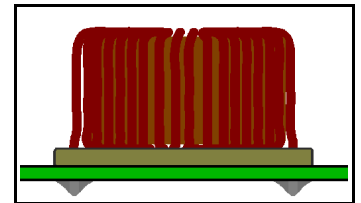

The Bridge rectifiers will need to be mounted higher off the PCB, for a couple of reasons, firstly Data sheets for Bridge rectifiers showed showed a variation of up to 2mm in the spacing between the legs of the bridges so the legs may have to spread out slightly. Secondly the Bridges get rather warm during operation and mounting them off the board allows for better cooling.

You will need to fit heatsinks to the bridge rectifiers (I used spare pieces of angle Aluminium) and check how they fit in around the Main filter capacitors and fuses.

The 3.5mm wide hole under the rectifier is so you can insert a (thin) screwdriver under the Bridge for tightening screws as, or if required or use a spacer between the Bridge and the PCB and then run a long bolt up from the underside of the PCB into the heatsink, **note** you will need to insulate any metalwork from the PCB and I suggest using either an insulated or non conductive spacer. If you use a spacer then bolt the Bridge firmly in place before soldering, as this will avoid placing undue stress on the soldered joints.

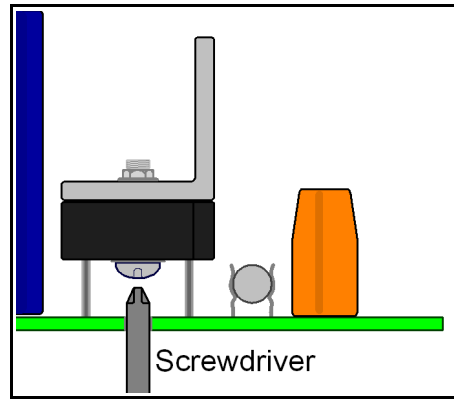
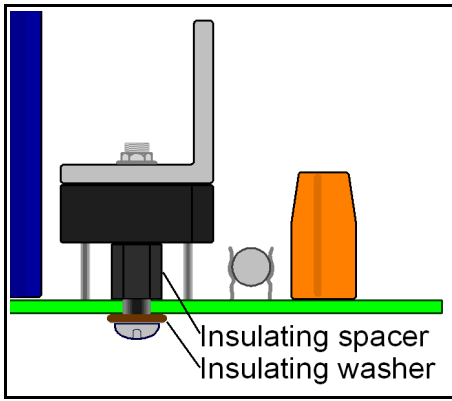

Wires may be soldered directly to the PCB, or you can use screw terminals if you like. Direct soldering saves a few dollars and potentially increases reliability, as screw terminations may be prone to loosening in a high vibration/movement environment such as may be found on the road.

Finally turn the board over and solder on C13 as shown in the picture below

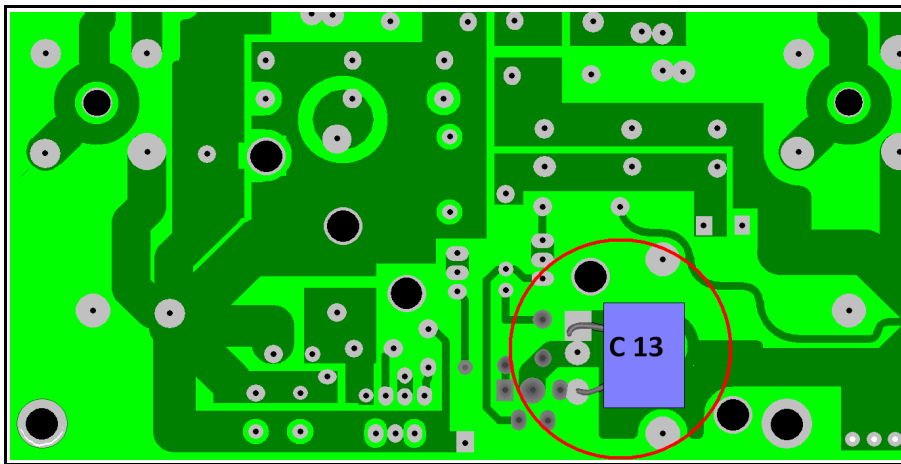

Secondary Filter

If you do not wish to use the secondary filter, then link out Inductors **L2, L12,L22** as shown below (only **L2** shown, link out **L12** and **L22** in the same way).and leave off capacitors **C101, C102, C111, C112, C211,C212**.

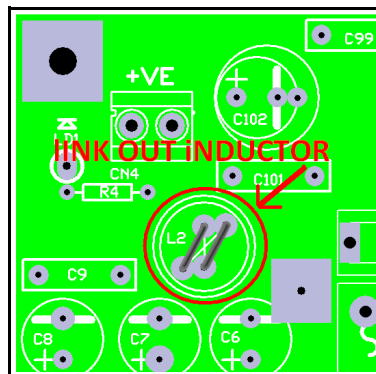

Connecting the Transformer

Each winding of the transformer goes to one of the two AC connectors as shown below (this diagram presumes one winding uses the Red/Yellow wires and the other the Black/White wires).

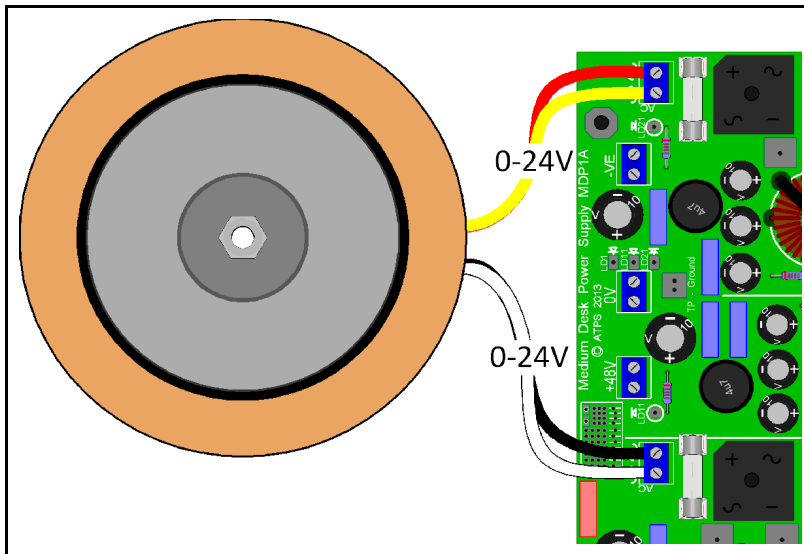

Connecting the LEDs

While as a general rule I try to avoid off board wiring as much as possible, however any LEDs mounted directly on the PCB may have been obscured by heat sinking so the Rail indicator LEDs will need to be wired as per the diagram below.

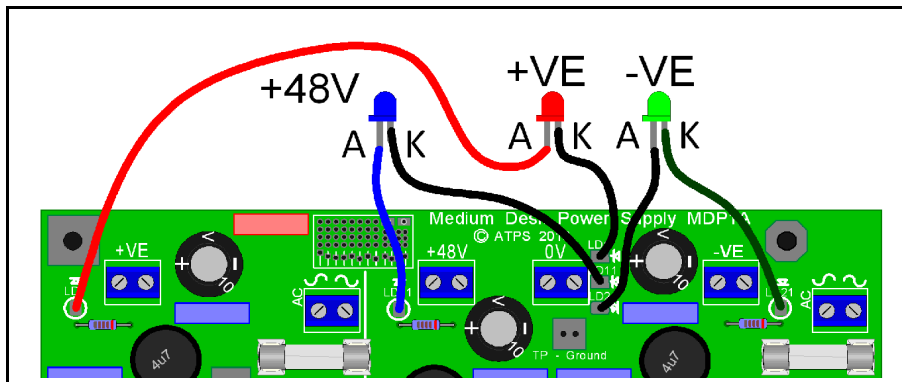

Regulator mounting

The regulators will need to be insulated from the heatsink or case using either Mica washers or Silicone pads. While I would suggest Mica washers for higher performance applications in this case either would be adequate. If using mica washers you will need to apply a thin smear of heatsink compound either side of the washer, this only needs to be enough to fill any little gaps between the regulator and the washer or the heatsink and the washer.

Also you will need to use an insulating bush between the bolt and the Regulator. Note the bolt will need to be an M3 or 3mm bolt, as 1/8 bolts usually do not fit in a TO220 bush.

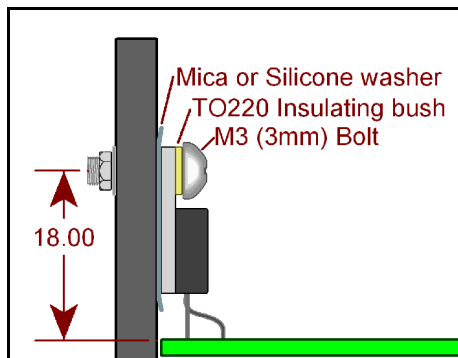

Parts list

Electronics

(Parts in *blue Italics* may vary depending on Transformer selection etc. - see notes)

QTY	Description	Reference	Notes
2	10 Amp bridge (MP1004G)	BR1,BR21	
1	0u1F 230V Poly	C99	
2	<i>10,000uF 45V (30mm Dia, 10mm pitch)</i>	<i>C1,C21</i>	
2	<i>10nF 50V Poly (soft-start)</i>	<i>C4,C24</i>	
2	10nF 50V Poly	C5,C25	
1	150nF 100V Poly	C15	
5	1uF 63V Poly	C2-3,C13,C22-23	
1	<i>220uF 63V Low ESR</i>	<i>C112</i>	
3	470nF 63V Poly	C9,C19,C29	
3	<i>470nF 63V Poly</i>	<i>C101,C111,C121</i>	
2	<i>470uF 25V Low ESR</i>	<i>C102,C122</i>	
6	47uF 25V Low ESR	C6-8, C26-28	
3	68uF 63V Low ESR	C16,C17,C18	
3	MBR1060 Schottky Diode	D1,D11,D21	
2	<i>6.3 Amp slow blow m205</i>	<i>F1,F21</i>	
1	LM2585T-ADJ	IC11	
2	LM2678T-ADJ	IC1,IC21	
1	<i>22uH Radial</i>	<i>L12</i>	
1	270uH Bourns 2117-H-RC	L11	
2	27uH Bourns 2206-H-RC	L1,L21	
2	<i>4.7uH Radial</i>	<i>L2,L22</i>	
2	11K 1% Metal film	R2,R22	
2	1K 1% Metal film	R4,R24	
1	1K2 1% Metal film	R11	
2	3K 1% Metal film	R13,R14	
1	56K 1% Metal film	R12	
2	5K 1% Metal film	R3,R23	
2	750R 1% Metal film	R1,R21	
3	500R 25 turn Vertical trimpot	VR1,VR11,VR21	
4	M205 PCB fuse clips	F1,F21	

Hardware

QTY	Description	Notes
1 or 2	Bridge heatsinks	
1	Dual 25v 300VA transformer	
3	TO220 insulating washers	
3	TO220 insulating bushes	
3	M3 bolts (and nuts)	
3	M3 washers	

