

PWM1B – Isolated PWM to Analog Converter

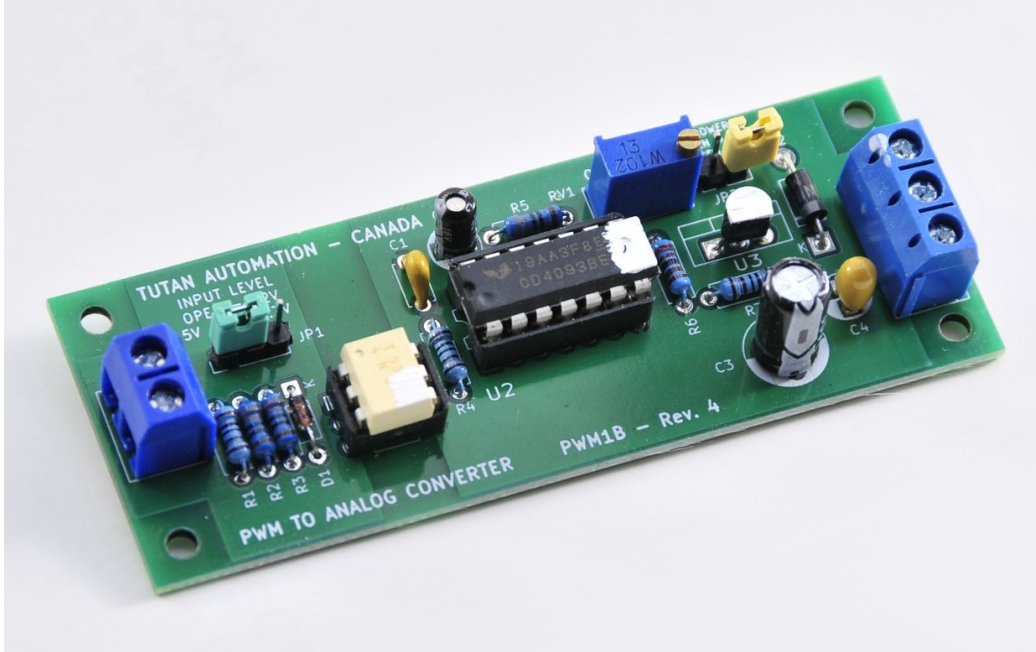

DESCRIPTION

This board contains one PWM to analog converter that provides a linear output proportional to the duty cycle of the input signal.

Its intended application is to interface micro-controllers with PWM outputs to industrial devices that require linear analog signals, such as Variable Frequency Drives (VFD), direct flame burners, etc.

FEATURES

- Adjustable output level
- Optical isolation
- Independent channels
- Through hole components
- Socket mounted ICs
- Sturdy construction
- Fits in standard DIN rail enclosure (not supplied)

SPECIFICATIONS

1. Number of channels: 1
 - PWM input level: 3.3, 5, 12V Selectable
 - Max frequency:
 - Input current: 5mA @ 5V
 - Output: Adjustable 0 to 5..12V or equal to Power Supply
 - Linearity: 2% FSD
 - Isolation: Min. 500 Vac
 - Power: Nominal 24 Vdc (Acceptable range 17 to 30Vdc) See NOTE below.
 - Dimensions: 3.400 x 1.950 in. (87 x 50 mm) 1.22 oz (0.025 Kg)

UTILIZATION

SELECT INPUT LEVEL

Use jumper JP1 to select the desired input level. Leave the jumper open for 12V.

SELECT OPERATION MODE

Determine the mode of operation most suitable for your application: FIXED or ADJUSTABLE output MODE.

FIXED MODE:

Jumper JP2 must be CLOSED. Power supply must be in the range 6 to 15Vdc (higher voltages will damage the CD4093 chip in the board).

The output level will be from 0V to the actual power supply voltage used.

This mode is used when the target device provides a “wetting” voltage that also corresponds with the Full Scale Input required. Most VFD provide this voltage.

WARNING: Maximum voltage in this mode is 15Vdc.

ADJUSTABLE MODE:

Jumper JP2 must be OPEN. The output level will be from 0V to the value adjusted with the trim-pot RV1, in the range 5 to 12V. The boards are factory adjusted to 10Vdc output.

WIRING

PWM2B - TYPICAL WIRING

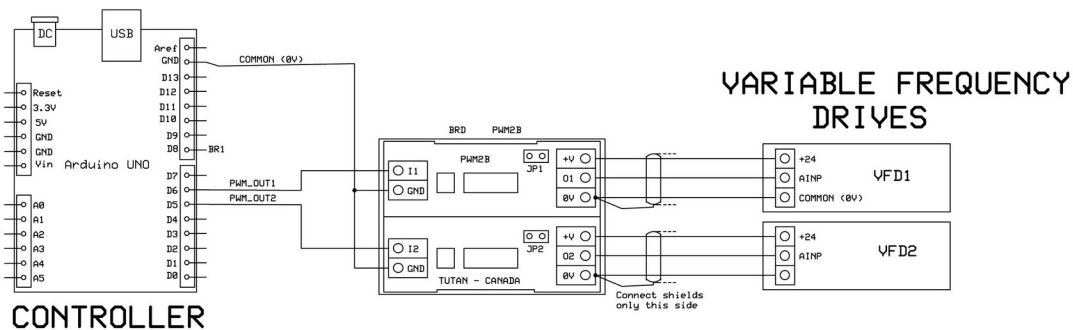

OUTPUT LEVEL ADJUST

Apply 5V to input (PWM=100%) and adjust trim-pot RV1 to desired value.

Verify that the output is 0-10mV with the input open (PWM=0%).

NOTE: It is recommended to adjust the output voltage with the board connected to the device in order to compensate for the voltage drop caused by the input resistance.

PWM1B – BOM

Item	Qty	Reference	Value
1	1	C1	100nF
2	1	C2	10uF/16V
3	1	C3	47uF/35V
4	1	C4	10uF/ 16VTANT
5	1	D1	1N4148
6	1	D2	1N4007
7	1	JP1	JUMPER
8	1	JP2	JUMPER
9	3	R1, R4, R7	1K
10	3	R2, R3, R5	330
11	1	R6	2K2
12	1	RV1	1KOhm
13	1	TB1	CONN_2_V
14	1	TB2	CONN_3_V
15	1	U1	4N35
16	1	U2	4093
17	1	U3	LM317AT
18	1	SK1	DIL6_300
19	1	SK2	DIL14_300
20	1	PCB	PWM1B-R4