

Industrial-grade LiFePo4 v.2.3 Charger module: PDCharger

by ProtoDevs® GmbH

Datasheet (Rev. 06.03.2025)

PDCharger Family description

The PDCharger is a smart charger module which manages the LiFePo4 battery charging with extended functions and I2C control/monitoring for Charger chip, Gauge chip and Microcontroller onboard.

The Charger supports the narrow VDC power path management, in which the system is regulated at a voltage slightly higher than the battery voltage without being allowed to drop below the minimum system voltage. The minimum system voltage allows the system to operate even when the battery is completely discharged or removed. When system power exceeds the input source rating, battery supplement mode supports the system power requirement without overloading the input source.

The device charges a battery from a wide range of the input sources including external DC adapter and Solar Panels to high voltage PD adapter and traditional barrel adapter. The charger automatically sets converter to be buck, boost or buck-boost configurations based on input voltage and battery voltage without the host control. The dual input source selector manages the power flowing from two different input sources. The inputs selection is controlled by the host through I2C with default source #1 (VAC1) as the primary input and the source #2 (VAC2) as the secondary input.

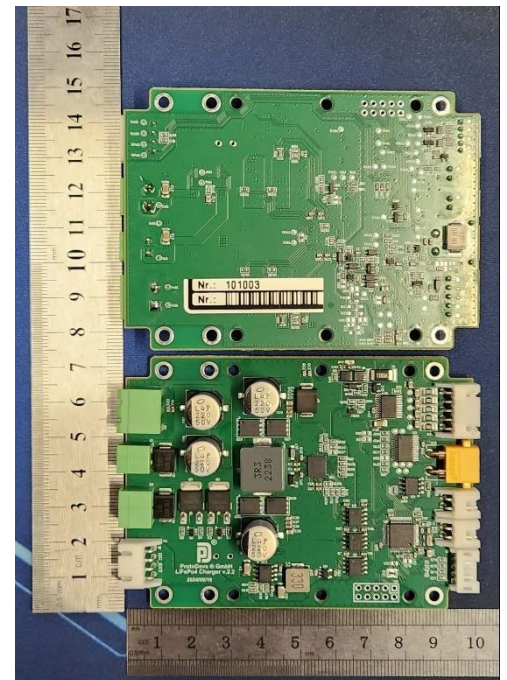

PDCharger module based on the newest STM32 microcontroller utilizing the power and cost-effectiveness of the latest industry standards. PDCharger could be customized for any type of battery.

There are several PDCharger variants available:

PDCharger v.2.3

up to 12V @ **12A+** load, **ALLOWED** to connect I2C monitoring/control interface to the Load side (no loopback issue)

Table of Contents

PDCharger Family description	1
Simplified block diagram	3
Operational conditions	3
General specifications	4
Electrical specifications	5
Mechanical dimensions (PDCharger module)	6
PDCharger module installation and operating requirements	7
Mounting requirements:	7
LiFePo4 Battery balancer connector pinout (a must)	7
Connection sequence requirements:	8
PDCharger module programming/flashing recommendations	9
PDCharger module mounting recommendations	10
External connectors placement	11
Preparations for PDCharger module communication	14
List of commands supported (I2C)	15

Simplified block diagram

(For PDCharger v.2.3)

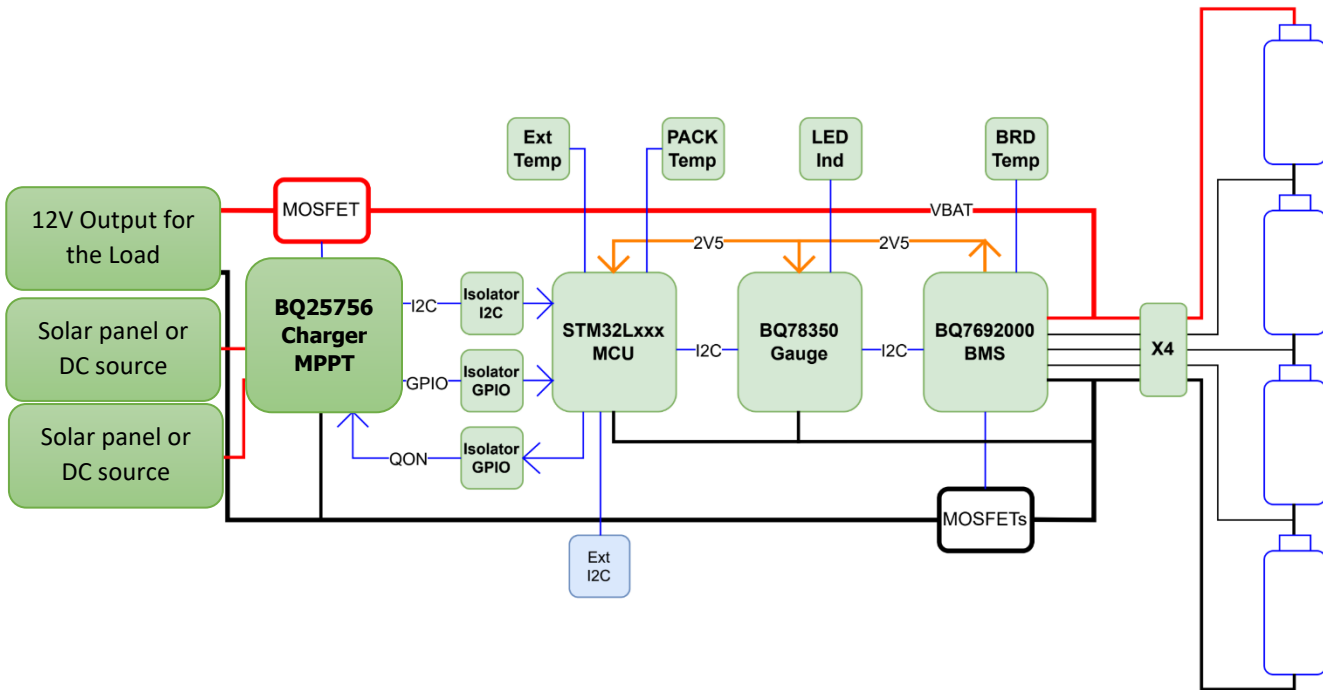

Operational conditions

Operational temperature:	-40 ... 85 C
Storage temperature:	-55 to 150 C
Input voltages range (X1, X2 connectors) :	3.6V to 24V wide input voltage
ESD rating:	Charged device model (CDM), per JEDEC specification JESD22-C101, all V pins: +-250V
Max batteries charging current supported:	5A by default (see API)
Mass:	48 grams for v.2.3
Communication speed (I2C bus):	up to 1 Megabit per second (1 Mbps)



General specifications

PDCharger v.2.3 typical connection diagram:

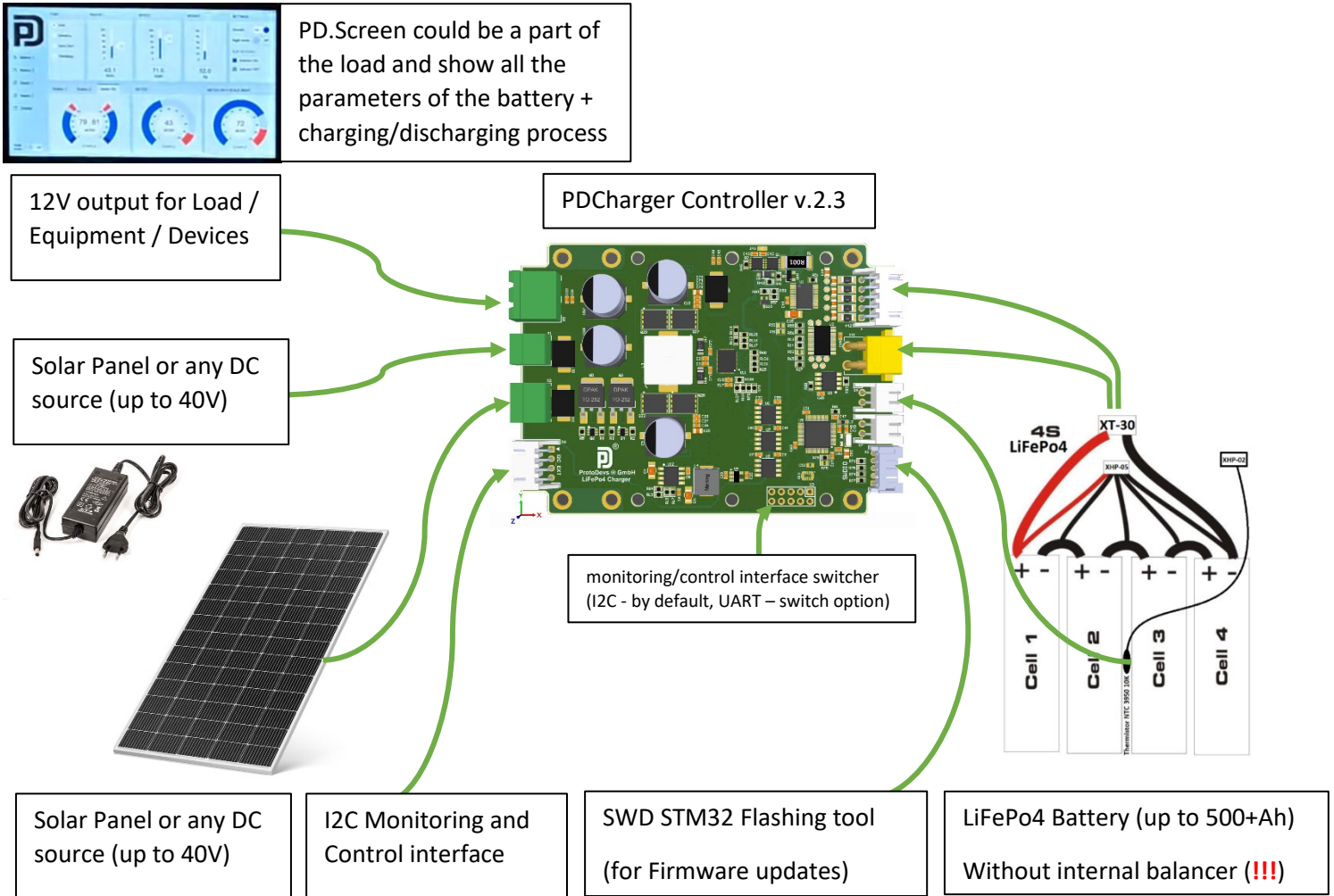

PDCharger Controller consists of 4 major blocks: [SMT32 MCU](#), [BMS chip](#), [Gauge chip](#) and [Charger chip](#).

The default configuration of the PDCharger v.2.3 is designed to use all the possible information to provide detailed information regarding the battery status and load status during the idle load operation, charging or discharging states.

The strict requirement is to use LiFePo4 batteries **without any** additional electronics inside the battery pack (load balancers, protection circuits) because everything already implemented on the PDCharger side.

If there is an emergency case that no other variant exist and the system should work with the battery pack balancer then there is a strict rule to turn OFF the PDCharger internal balancer to avoid two balancers working at the same time. The API command could be found in this document to turn OFF the PDCharger balancer.

Mechanical dimensions (PDCharger module)

(For PDCharger v.2.3)

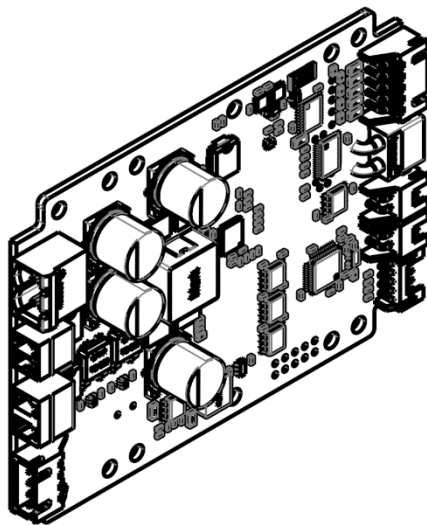
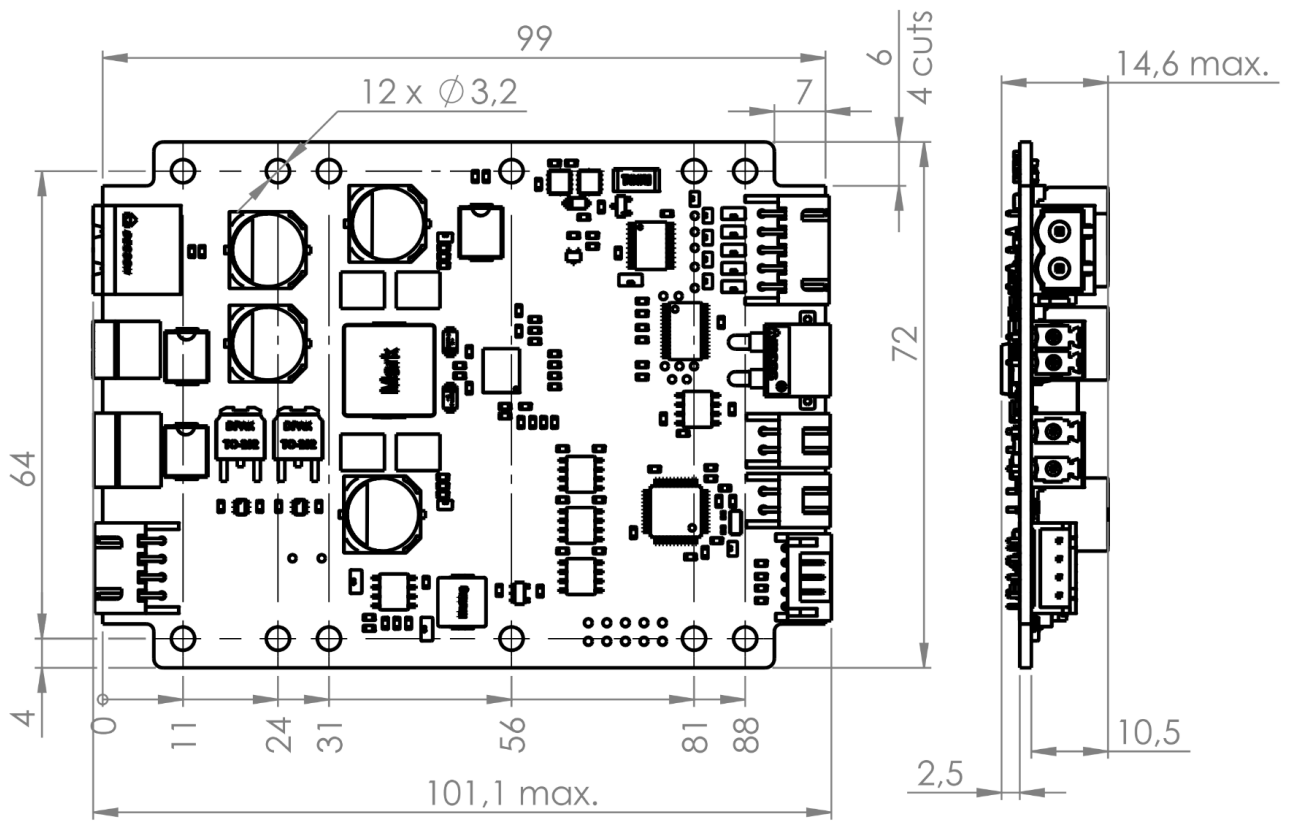

PDCharger module installation and operating requirements

Mounting requirements:

There are 6 mounting holes for the mechanical fixing the charger module inside the enclosure, they marked with the red arrows on the picture :

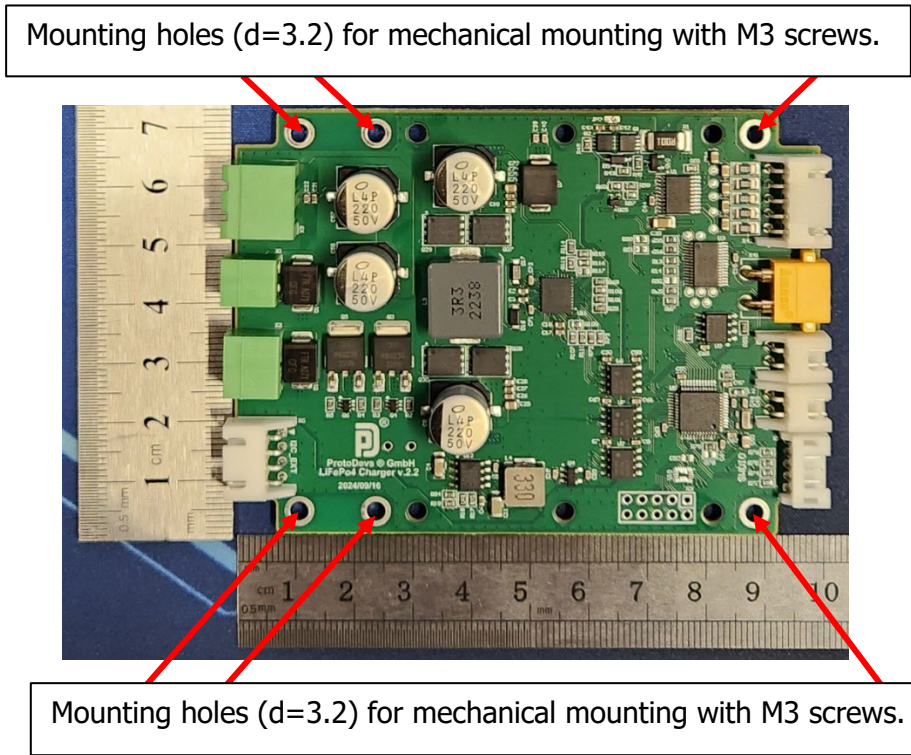

Use only the marked holes for the mechanical fixing.

LiFePo4 Battery balancer connector pinout (a must)

There is a strict requirement for the balancer connector pinout from the external LiFePo4 battery, in other case the Charger module will turn ON the protection and will not work (no output):

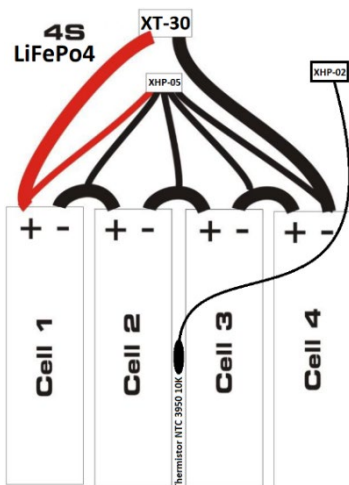

Battery balancer pinout	
XHP-05 connector pin	connect to
1 (Red wire)	+ 12.8V
2 (Black wire)	+ 9.6V
3 (Black wire)	+ 6.4V
4 (Black wire)	+ 3.2V
5 (Black wire)	GND

Connection sequence requirements:

There is a special connection sequence exists in order to start the device properly due to the POST (Power On Self-Test) procedure:

Step 1: Connect Battery temperature connector (2 pin, white -> to X8)

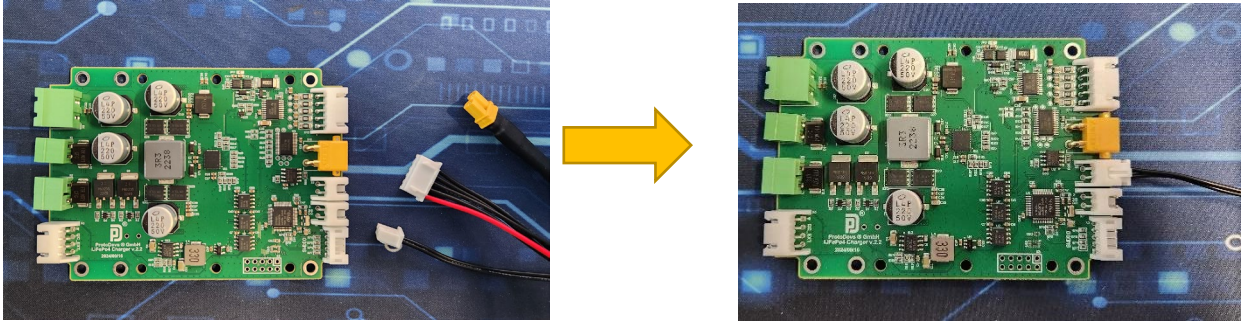

Step 2: Connect LiFePo4 Battery connector (2 pin, orange -> to X41)

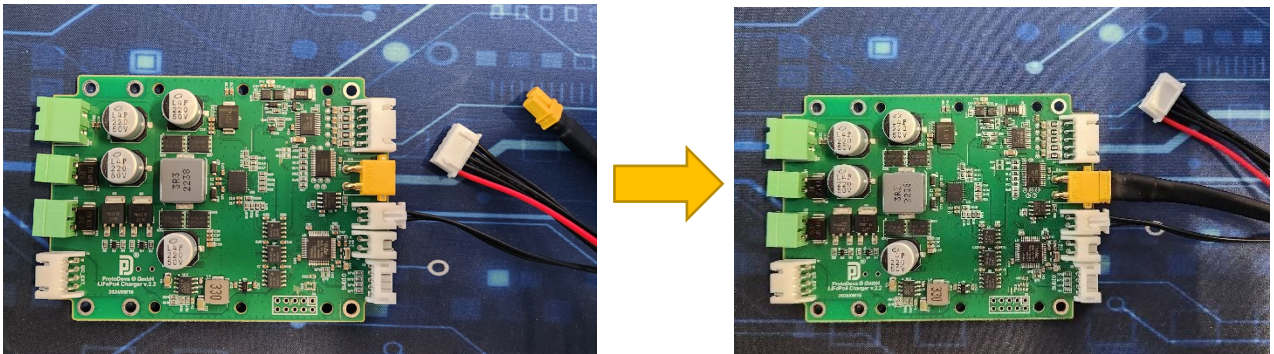

Step 3: Connect Battery balancer connector (5 pin, white -> to X42)

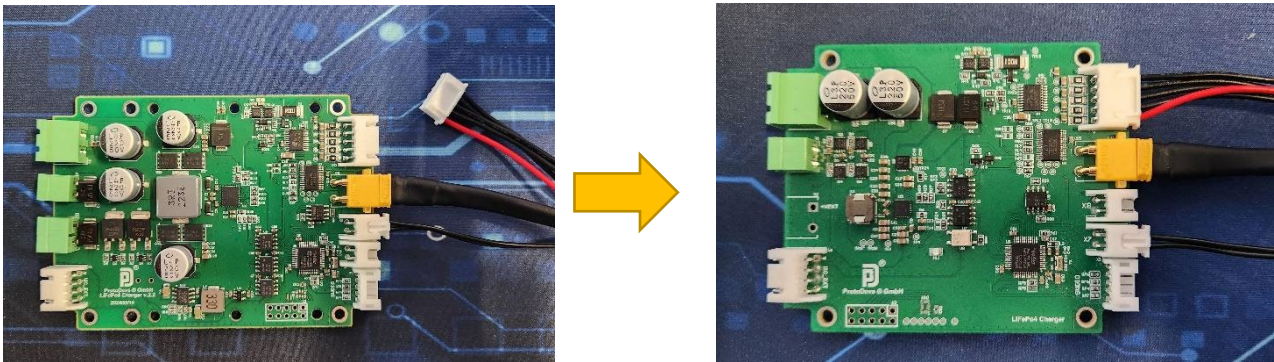

Connect the Load **ONLY** after connecting the battery (these 3 steps described)

To obtain correct (precise) "state of charge" parameters there is a must to connect 100% charged battery from the very first installation, in other case several discharge-charge cycles are needed for system to calibrate itself.

PDCharger module programming/flashing recommendations

PDCharger module has so called SWDIO interface to program/flash the Firmware.

If there is a need to update the Firmware then it is recommended to use ST-Link V2 programmer/flasher as the easiest way to proceed.



Connection diagram for programming/flashing the Firmware:

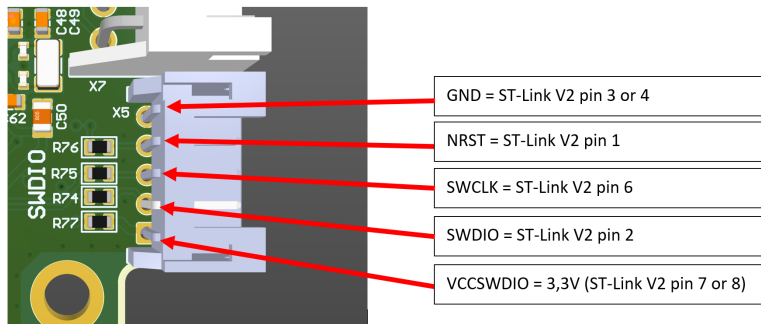

The Software to program/flash the PDCharger module: **STM32CubeProgrammer** ([Link](#))

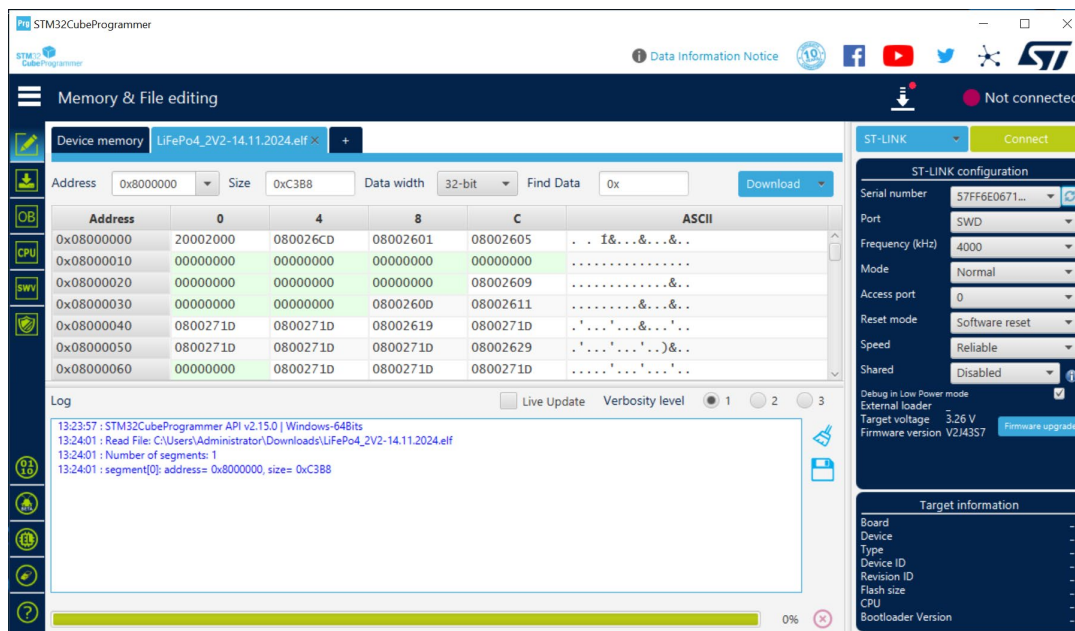

PDCharger module mounting recommendations

Outdoor installation of the PDCharger modules require certain type of protection and climatic considerations to follow.

The module should be mounted into enclosure which is a solid metal, outdoor plastic or similar material which gives fully weatherproof barrier but also through climatic controls ensures the interior of the enclosure is the optimum environment for running the charger module – no matter what the ambient conditions or temperatures are like.

1. Install lightning protection devices

In outdoor environments, lightning protection devices must be installed for the charger placement enclosure and the building where it is located. The main body and casing of the module should be well grounded, and the grounding resistance should be less than **3 Ohms** to ensure that the large current caused by lightning can be discharged in time. Effective lightning protection measures can prevent strong electric and magnetic attacks on the charger module caused by lightning, thereby protecting the safety of the equipment.

2. Waterproof measures

Outdoor charging modules must have excellent waterproof performance. Since the outdoor environment is often exposed to the sun, rain, wind and dust, the charger may face serious challenges in waterproofing and moisture resistance. Once electronic equipment is wet or damp, it may cause a short circuit or even a fire, causing serious losses. Therefore, waterproof enclosure design is the key to ensure the long-term stable operation of the charger

3. Ventilation and cooling

In order to prevent the charger module from malfunctioning due to overheating, ventilation equipment must be installed for cooling. Usually, an axial fan is installed above the back of the rack where the module is mounted to discharge heat and ensure that the internal temperature of the module is maintained between -30°C and 80°C. If the heat dissipation is poor, the integrated circuit may be abnormal or even burn out, causing the display system to fail to work properly.

The installation of the outdoor PDCharger modules must consider the requirements of lightning protection, waterproofing, moisture-proofing and heat dissipation. Only by making full preparations for these details can ensure that the module can operate stably and efficiently in various harsh environments and provide users with high-quality charging services.

External connectors placement

PDCharger (v.2.3):

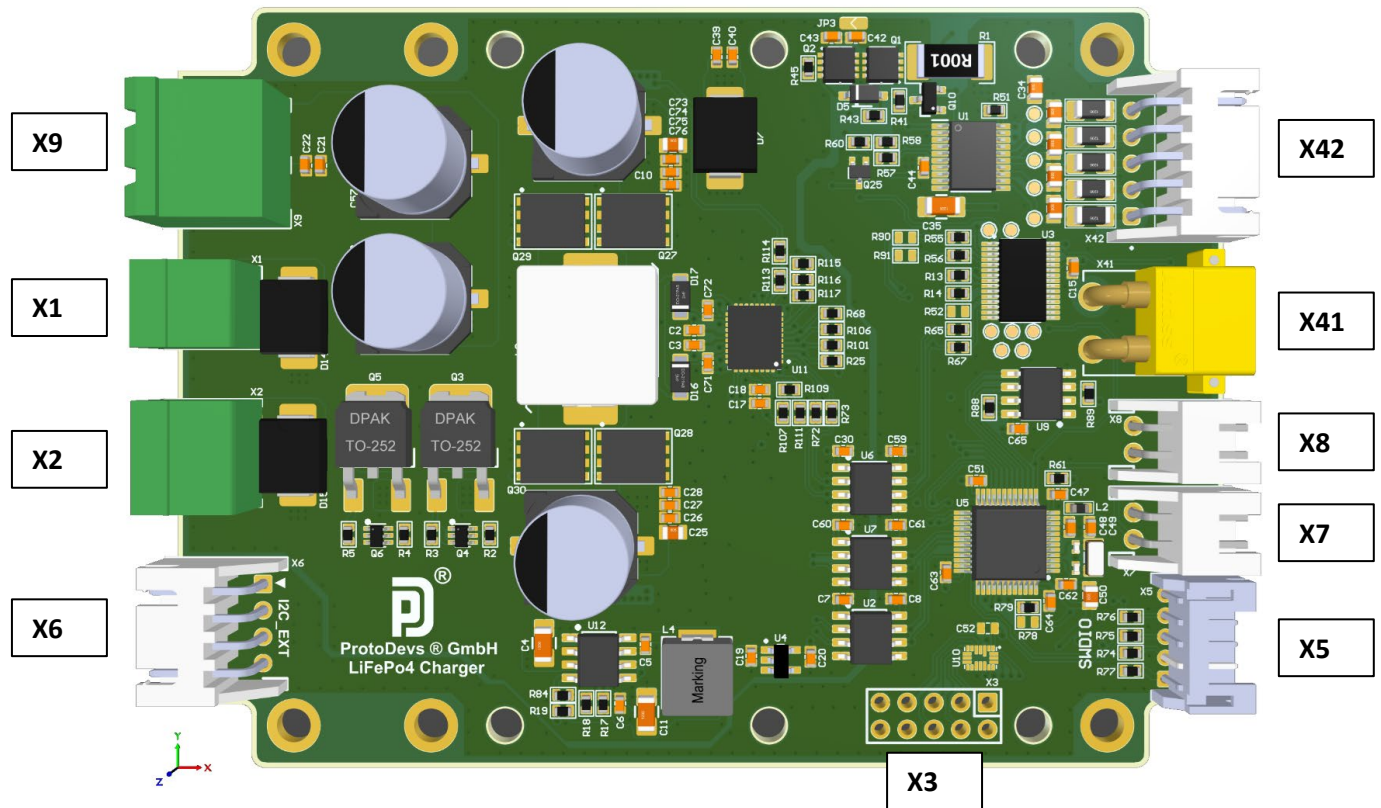

- X1:** Input, input #1 (3.6-V to 24-V wide input operating voltage) :
Solar panel or external DC
Partnumber : 15EDGRC-3.5-02P
- X2:** Input, input #2 (3.6-V to 24-V wide input operating voltage) :
Solar panel or external DC
Partnumber : 15EDGRC-5.08-02P-14
- X9:** Output, From 2.5 V to 19.4V regulated output ;
By default = 12V (factory settings) but depends on LiFePo battery output voltage
X9 output follows the battery if not in charging mode
Nominal = 12,8V ; Maximum = 14,4V ; Minimum = 10V ;
Partnumber : 2EDGRC-5.08-02P-14-100A
- X41:** Input , LiFePo 4 battery main cables connector (high current)
Partnumber : XT30PW-M
- X7 :** Input , NTC could be connected here (NTC 10k 1% 3905), for example [THIS ONE](#)
Partnumber : S2B-XH-A
- X8 :** Input , NTC from the **LiFePo battery Temp sensor must be connected** here (NTC 10k 1% 3905),
Partnumber : S2B-XH-A

X5: SWDIO STM32 programming connector
(Scheme part from the PCB side)

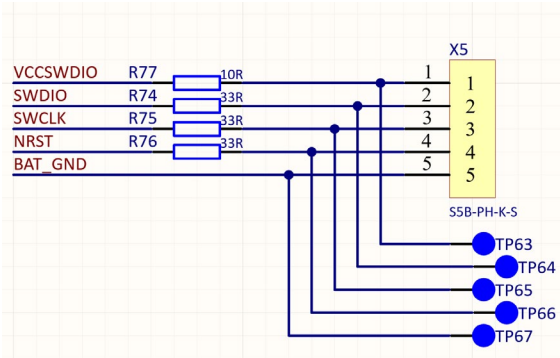

Partnumber : S5B-PH-K-S

X6: I2C EXT connector, for connecting external I2C devices for debug purposes
(Scheme part from the PCB side).

PDCharger v.2.2 must not have connected this I2C interface to the load side
PDCharger v.2.3 allows to connect this I2C interface to the load side

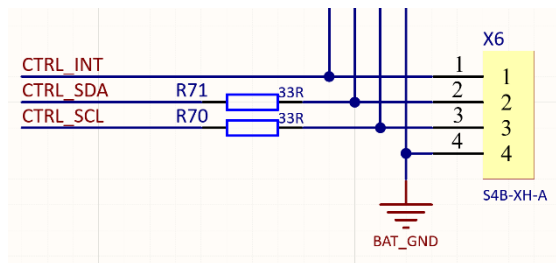

Attention!
 The SDA and SCL lines on the Charger PCB have **10k** pull-ups and ~2,5V voltage level. Connection to Charger PCB via I2C should be aligned by driver strength and voltage level.

Partnumber : S4B-XH-A

X42: Input, balancer cable input from the LiFePo external battery

Partnumber : S5B-XH-A

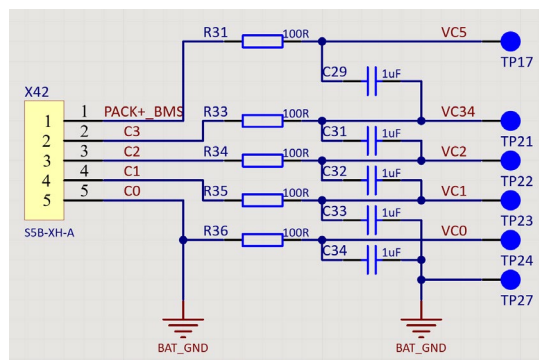

X3: Optional connector, could be not mounted. For I2C changing address use only

Partnumber : ZX-PZ2.54-2-5PZZ

The alternative function of X6 connector is UART protocol instead of I2C, this setting is controlled by PB4 state on **X3 GPIO** extender area, default interface is I2C (EXT_SDA, EXT_SCL). In case of pulling up the **PB4** (10k resistor from PB4 to 2V5) to the high level, **SDA** becomes **TxD** and **SCL** becomes **RxD**. The PB4 check is executed every time the Charger PCB starts (powerup sequence).

More details you can find in the Charger API doc, please visit our forum for more details :

<https://www.protodevs.de/forum/>

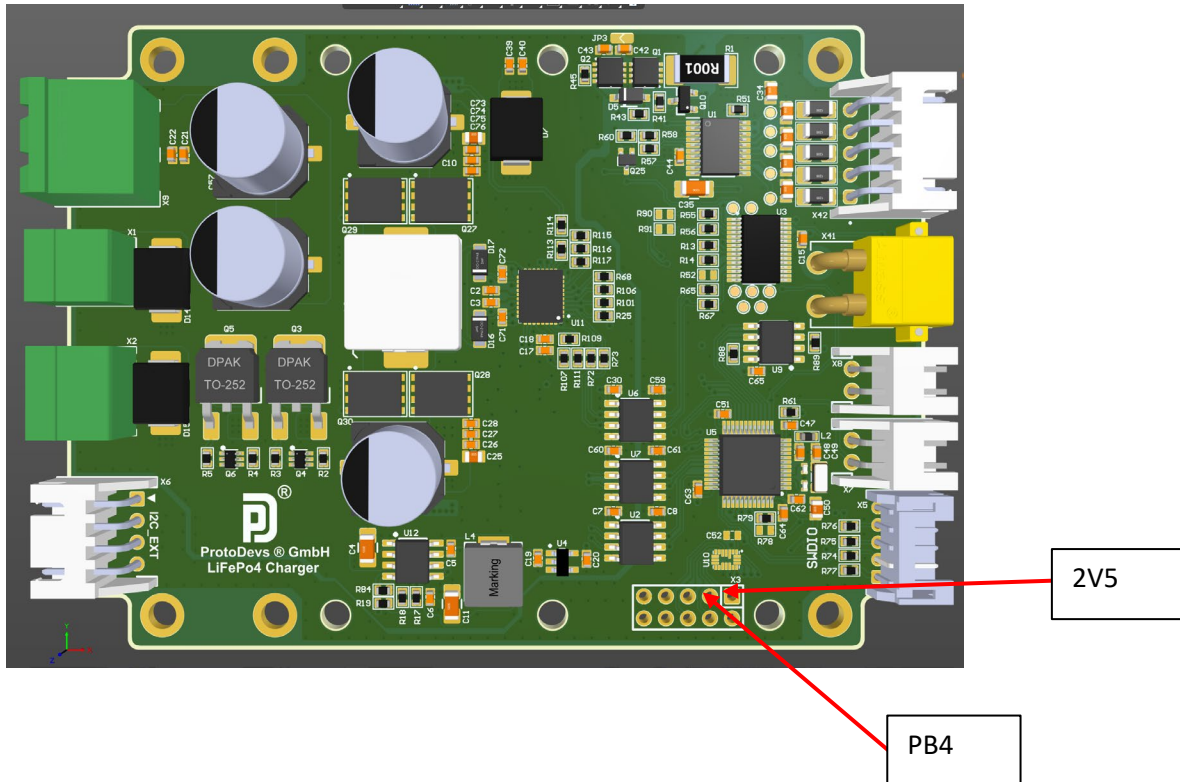

Preparations for PDCharger module communication

Board jumpers.

X3 port can be used for board configuration. Board reads jumpers during the startup.

Jumpers on pins PB0 and PB2 are used to change board i2c address.

Default address is 0x3B with jumpers you can increment the address on value from 0 to 0x10

- - pin not connected

0 - pin is LOW

1 - pin is HIGH

address increment: 0 2 4 6 8 A C E 10

pin PB0 state : - 0 1 - 0 1 - 0 1

pin PB2 state : - - - 0 0 0 1 1 1

Jumper on pin PB4 is used to specify communication format. default - i2c

format : I2C UART UART_HU

pin PB4 state: - 0 1

Communication formats.

I2C - used by default, tested at 100KHz speed, default board address is 0x3B.

You must know how many bytes you send, byte 0 in the response always contains the number of following bytes.

Connection:

SDA - X6.2,

SCL - X6.3,

GND - X6.4

UART - speed 115200. You must know how many bytes you send, byte 0 in the response always contains the number of following bytes.

All requests must contain one extra leading byte - number of following bytes. For example, command 00 01 in UART mode is 02 00 01,

where 02 is number of following bytes = 2.

Connection:

TxD - X6.2,

RxD - X6.3,

GND - X6.4

UART_HU - also uart, speed 115200, but in human-friendly format. you send/receive not bytes, but text representation of bytes separated with spaces.

Command is ended with ; character.

For example: 00 01; or 0 1;

Response in this format does not contain byte 0 and is ended with \n character.

List of commands supported (I2C)

Important note!

To preserve battery MCU sleeps most of the time. To start the communication X6.1 signal must be pulled LOW. Transition X6.1 from HIGH to LOW wakes up MCU, it stays awake for 5 seconds, communication must be started in 5 seconds after X6.1 changes from HIGH to LOW. MCU goes to sleep after 5 seconds after the last communication command.

Using crc.

Crc is disabled by default. To enable crc command 10 01 01 must be issued.

When crc is enabled:

- Each request from host to board must be trailed with 4 extra bytes - crc hash, LSB first.

For example, command to read if crc is used in requests/responses with disabled crc is

00 01

and with enabled crc same command is

00 01 69 22 DE 36

because crc32 hash of bytes 00 01 is 36DE2269

- Each response from board to host, except the error responses, is also trailed with 4 extra bytes - crc hash, LCB first.

CRC hash is calculated over the response bytes starting from 1! I.e. response byte 0 is not included in crc hash calculation.

Response byte 0 is a number of the following response bytes. It is appended to the response after crc hash calculation,

therefore is not included in crc calculation.

Error response is always 00, it is not trailed with crc hash.

For example, response with crc disabled is

01 01

Same response with crc enabled is

05 01 1B DF 05 A5

please note that crc hash A505DF1B is calculated over the 1 byte - 01. Byte 0 - 05 - is a number of the following bytes.

00 General information read.

Some information is unique, some duplicates charger/gauge register reads
response in case of command error: 00
Multibit numbers LSB first

00 - initialization status

request: 00 00

response: 01 BB

BB - 1 byte:

bit 0 = 1 - init error gauge,

bit 1 = 1 - gauge flash required update,

bit 2 = 1 - init error charger. charger state is updated on each iteration (every 5 seconds or

so)

bit 3 = 1 - custom charger configuration was used

01 - use crc in requests/responses

request: 00 01

response: 01 BB

BB - 1 byte:

0 - crc not used,

1 - crc is used

02 - charger Input Voltage for Max Power Point detected

request: 00 02

response: 02 BBBB

BBBB - 2 bytes. Content of charger REG0x1F_VAC_Max_Power_Point_Detected register

03 - charger MPPT status

request: 00 03

response: 02 BBBB

BBBB - 2 bytes. Content of charger REG0x1A_MPPT_Control register

04 - gauge temperature

request: 00 04

response: 02 BBBB

BBBB - 2 bytes. Result of gauge 0x08 Temperature() command

05 - gauge voltage

request: 00 05

response: 02 BBBB

BBBB - 2 bytes. Result of gauge 0x09 Voltage() command

06 - gauge current

request: 00 06

response: 02 BBBB

BBBB - 2 bytes. Result of gauge 0x0A Current() command

07 - gauge average current

request: 00 07

response: 02 BBBB

BBBB - 2 bytes. Result of gauge 0x0B AverageCurrent() command

08 - gauge max error

request: 00 08

response: 02 BBBB

BBBB - 2 bytes. Result of gauge 0x0C MaxError() command

09 - gauge relative state of charge

request: 00 09

response: 02 BBBB

BBBB - 2 bytes. Result of gauge 0x0D RelativeStateOfCharge() command

0A .. 0E - gauge cell voltage. 0A - 0x3E CellVoltage1() ... 0E - 0x3A CellVoltage5()

request: 00 0A

response: 02 BBBB

BBBB - 2 bytes. Result of gauge 0x3E CellVoltage1() ... 0x3A CellVoltage5() command

0F - gauge full charge capacity

request: 00 0F

response: 02 BBBB

BBBB - 2 bytes. Result of gauge 0x10 FullChargeCapacity() command

10 - gauge charging current

request: 00 10

response: 02 BBBB

BBBB - 2 bytes. Result of gauge 0x14 ChargingCurrent() command

11 - gauge charging voltage

request: 00 11

response: 02 BBBB

BBBB - 2 bytes. Result of gauge 0x15 ChargingVoltage() command

12 - gauge battery status

request: 00 12

response: 02 BBBB

BBBB - 2 bytes. Result of gauge 0x16 BatteryStatus() command

13 - gauge charging status

request: 00 13

response: 02 BBBB

BBBB - 2 bytes. Result of gauge 0x0055 ChargingStatus command

14 - gauge gauging status

request: 00 14



response: 02 BBBB

BBBB - 2 bytes. Result of gauge 0x0056 GaugingStatus command

15 - gauge manufacturing status

request: 00 15

response: 02 BBBB

BBBB - 2 bytes. Result of gauge 0x0057 ManufacturingStatus command

16 - gauge AFE status

request: 00 16

response: 02 BBBB

BBBB - 2 bytes. Result of gauge 0x0058 AFESTatus command

17 - read flash settings

request: 00 17

response: 0E BBBB BBBB...

BBBB - 7 2-byte numbers, LSB first. First 4 numbers are reserved, numbers 4-7 can be used for user data:

0 - charger voltage threshold,

1 - input current for low voltage,

2 - input current for high voltage,

3 - configuration flags. bit 0 - enable MPPT in cycle, bit 1 - update input current in cycle

18 - read flash content

request: 00 18 AAAAAA CC

AAAAAA - 3 bytes. flash address. from 0 to 512 KBytes

CC - 1 byte. number of bytes to read. from 1 to 32

response: CC BB...

CC - 1 byte. Number of bytes in the response

BB... - CC bytes of flash content

19 - read custom charger registers configuration

request: 00 19

response: 1F BB...BB BBBB...BBBB

1F - 1 byte. Number of bytes in the response

BB...BB - 15 1-byte registers:

REG0x14_Precharge_and_Termination_Control,

REG0x15_Timer_Control,

REG0x16_ThreeStage_Charge_Control,

REG0x17_Charger_Control,

REG0x19_Power_Path_and_Reverse_Mode_Control,

REG0x1A_MPPT_Control,

REG0x1B_TS_Charging_Threshold_Control,

REG0x1C_TS_Charging_Region_Behavior_Control,

REG0x1D_TS_Reverse_Mode_Threshold_Control,

REG0x1E_Reverse_Undervoltage_Control,

REG0x2B_ADC_Control,



REG0x2C_ADC_Channel_Control,
 REG0x3B_Gate_Driver_Strength_Control,
 REG0x3C_Gate_Driver_Dead_Time_Control,
 REG0x62_Reverse_Mode_Battery_Discharge_Current
 BBBB...BBBB - 8 2-byte registers, LSB first:
 REG0x00_Charge_Voltage_Limit,
 REG0x02_Charge_Current_Limit,
 REG0x06_Input_Current_DPM_Limit,
 REG0x08_Input_Voltage_DPM_Limit,
 REG0x0A_Reverse_Mode_Input_Current_Limit,
 REG0x0C_Reverse_Mode_Input_Voltage_Limit,
 REG0x10_Precharge_Current_Limit,
 REG0x12_Termination_Current_Limit

1A - read MCU ticks since start. Normally 1 tick = 1 msec but ticks are stopped during sleep. This command can be used to find out if MCU restart happened since previous command

request: 00 19

response: BBBB BBBB

BBBB BBBB - 4 bytes. number of ticks since MCU start

1B - read firmware revision

request: 00 20

response: 0E DD...DD.BBBB

DD...DD - 11 bytes, build date in format 'MMM DD YYYY', ex: Sep 19 2024

. - 1 byte = '.'

BBBB - 2 bytes, build number byte in hex format

10 General information write

response in case of command error: 00

response in case of command success: 01 01

00 - restart

request: 10 00 BB

BB - 1 byte. 1 - restart

01 - set use/not use crc

request: 10 01 BB

BB - 1 byte. 0 - not use crc, 1 - use crc

02 - close/open gauge FETs

request: 10 02 BB

BB - 1 byte. 0 - close FETs, 1 - open FETs

03 - write flash settings

request: 10 03 BBBB BBBB...



BBBB - 7 2-byte numbers, LSB first. First 4 numbers are reserved, numbers 4-7 can be used for user data:

- 0 - charger voltage threshold,
- 1 - input current for low voltage,
- 2 - input current for high voltage,
- 3 - configuration flags. bit 0 - enable MPPT in cycle, bit 1 - update input current in cycle

04 - write flash content. Writes arbitrary content to flash. Up to 32 bytes. Address must be 0x2000 or more. Just writes, does not erase.

request: 10 04 AAAAAA CC BB...

AAAAAA - 3 bytes. flash address. from 0x2000 to 0x80000

CC - 1 byte. number of bytes to write. from 1 to 32

BB... - CC bytes to write to flash content

05 - erase flash sector. Erases flash sector. Sector size is 4096bytes, sectors 2 to 127 are allowed for user use

request: 10 05 AAAAAA

AAAAAA - 3 bytes. flash sector address. 0..4095 - sector 0, 4096..8191 - sector 1, etc.

06 - write custom charger registers configuration. these register values will be loaded to charger on the next charger start

request: 10 06 BB...BB BBBB...BBBB

BB...BB - 15 1-byte registers:

REG0x14_Precharge_and_Termination_Control,
 REG0x15_Timer_Control,
 REG0x16_ThreeStage_Charge_Control,
 REG0x17_Charger_Control,
 REG0x19_Power_Path_and_Reverse_Mode_Control,
 REG0x1A_MPPT_Control,
 REG0x1B_TS_Charging_Threshold_Control,
 REG0x1C_TS_Charging_Region_Behavior_Control,
 REG0x1D_TS_Reverse_Mode_Threshold_Control,
 REG0x1E_Reverse_Undervoltage_Control,
 REG0x2B_ADC_Control,
 REG0x2C_ADC_Channel_Control,
 REG0x3B_Gate_Driver_Strength_Control,
 REG0x3C_Gate_Driver_Dead_Time_Control,
 REG0x62_Reverse_Mode_Battery_Discharge_Current

BBBB...BBBB - 8 2-byte registers, LSB first:

REG0x00_Charge_Voltage_Limit,
 REG0x02_Charge_Current_Limit,
 REG0x06_Input_Current_DPM_Limit,
 REG0x08_Input_Voltage_DPM_Limit,
 REG0x0A_Reverse_Mode_Input_Current_Limit,
 REG0x0C_Reverse_Mode_Input_Voltage_Limit,
 REG0x10_Precharge_Current_Limit,
 REG0x12_Termination_Current_Limit

special request: 10 06 FF - erases custom charger registers configuration and makes charger use the default configuration

07 - write gauge balancing configuration. Flash address 0x460C. After flash is updated gauge must be restarted for settings to be applied. Since this setting is in flash it remains unchanged after the restart or power reconnect.

request: 10 07 BB RR

BB - 1 byte. Content of flash address 0x460C. 0 - disable cell balancing, 1 - enable cell balancing

RR - 1 byte. 1 - restart gauge to apply new settings

08 - write battery capacity to gauge, adjusts related settings accordingly - design capacity, learned FCC, newr full, etc. After flash is updated gauge must be restarted for settings to be applied.

request: 10 08 BBBB RR

BBBB - 2 bytes. Battery design capacity value, LSB first. Allowed range 1000 - 32767

RR - 1 byte. 1 - restart gauge to apply new settings

01 Charger registers read

response in case of command error: 00

Multibit numbers LSB first

00 - REG0x00_Charge_Voltage_Limit Register

request: 01 00

response: 02 BBBB

BBBB - 2 bytes. Content of charger REG0x00_Charge_Voltage_Limit Register

02 - REG0x02_Charge_Current_Limit Register

request: 01 02

response: 02 BBBB

BBBB - 2 bytes. Content of charger REG0x02_Charge_Current_Limit Register

06 - REG0x06_Input_Current_DPM_Limit Register

request: 01 06

response: 02 BBBB

BBBB - 2 bytes. Content of charger REG0x06_Input_Current_DPM_Limit Register

08 - REG0x08_Input_Voltage_DPM_Limit Register

request: 01 08

response: 02 BBBB

BBBB - 2 bytes. Content of charger REG0x08_Input_Voltage_DPM_Limit Register

0A - REG0x0A_Reverse_Mode_Input_Current_Limit Register

request: 01 0A

response: 02 BBBB

BBBB - 2 bytes. Content of charger REG0x0A_Reverse_Mode_Input_Current_Limit Register

0C - REG0x0C_Reverse_Mode_Input_Voltage_Limit Register

request: 01 0C

response: 02 BBBB

BBBB - 2 bytes. Content of charger REG0x0C_Reverse_Mode_Input_Voltage_Limit Register

10 - REG0x10_Precharge_Current_Limit Register

request: 01 10

response: 02 BBBB

BBBB - 2 bytes. Content of charger REG0x10_Precharge_Current_Limit Register

12 - REG0x12_Termination_Current_Limit Register

request: 01 12

response: 02 BBBB

BBBB - 2 byte. Content of charger REG0x12_Termination_Current_Limit Register

14 - REG0x14_Precharge_and_Termination_Control Register

request: 01 14

response: 01 BB

BB - 1 byte. Content of charger REG0x14_Precharge_and_Termination_Control Register

15 - REG0x15_Timer_Control Register

request: 01 15

response: 01 BB

BB - 1 byte. Content of charger REG0x15_Timer_Control Register

16 - REG0x16_ThreeStage_Charge_Control Register

request: 01 16

response: 01 BB

BB - 1 byte. Content of charger REG0x16_ThreeStage_Charge_Control Register

17 - REG0x17_Charger_Control Register

request: 01 17

response: 01 BB

BB - 1 byte. Content of charger REG0x17_Charger_Control Register

18 - REG0x18_Pin_Control Register

request: 01 18

response: 01 BB

BB - 1 byte. Content of charger REG0x18_Pin_Control Register

19 - REG0x19_Power_Path_and_Reverse_Mode_Control Register

request: 01 19

response: 01 BB

BB - 1 byte. Content of charger REG0x19_Power_Path_and_Reverse_Mode_Control Register

1A - REG0x1A_MPPT_Control Register

request: 01 1A



response: 01 BB

BB - 1 byte. Content of charger REG0x1A_MPPT_Control Register

1B - REG0x1B_TS_Charging_Threshold_Control Register

request: 01 1B

response: 01 BB

BB - 1 byte. Content of charger REG0x1B_TS_Charging_Threshold_Control Register

1C - REG0x1C_TS_Charging_Region_Behavior_Control Register

request: 01 1C

response: 01 BB

BB - 1 byte. Content of charger REG0x1C_TS_Charging_Region_Behavior_Control Register

1D - REG0x1D_TS_Reverse_Mode_Threshold_Control Register

request: 01 1D

response: 01 BB

BB - 1 byte. Content of charger REG0x1D_TS_Reverse_Mode_Threshold_Control Register

1E - REG0x1E_Reverse_Undervoltage_Control Register

request: 01 1E

response: 01 BB

BB - 1 byte. Content of charger REG0x1E_Reverse_Undervoltage_Control Register

1F - REG0x1F_VAC_Max_Power_Point_Detected Register

request: 01 1F

response: 02 BBBB

BBBB - 2 bytes. Content of charger REG0x1F_VAC_Max_Power_Point_Detected Register

21 - REG0x21_Charger_Status_1 Register

request: 01 21

response: 01 BB

BB - 1 byte. Content of charger REG0x21_Charger_Status_1 Register

22 - REG0x22_Charger_Status_2 Register

request: 01 22

response: 01 BB

BB - 1 byte. Content of charger REG0x22_Charger_Status_2 Register

23 - REG0x23_Charger_Status_3 Register

request: 01 23

response: 01 BB

BB - 1 byte. Content of charger REG0x23_Charger_Status_3 Register

24 - REG0x24_Fault_Status Register

request: 01 24

response: 01 BB

BB - 1 byte. Content of charger REG0x24_Fault_Status Register



25 - REG0x25_Charger_Flag_1 Register

request: 01 25

response: 01 BB

BB - 1 byte. Content of charger REG0x25_Charger_Flag_1 Register

26 - REG0x26_Charger_Flag_2 Register

request: 01 26

response: 01 BB

BB - 1 byte. Content of charger REG0x26_Charger_Flag_2 Register

27 - REG0x27_Fault_Flag Register

request: 01 27

response: 01 BB

BB - 1 byte. Content of charger REG0x27_Fault_Flag Register

28 - REG0x28_Charger_Mask_1 Register

request: 01 28

response: 01 BB

BB - 1 byte. Content of charger REG0x28_Charger_Mask_1 Register

29 - REG0x29_Charger_Mask_2 Register

request: 01 29

response: 01 BB

BB - 1 byte. Content of charger REG0x29_Charger_Mask_2 Register

2A - REG0x2A_Fault_Mask Register

request: 01 2A

response: 01 BB

BB - 1 byte. Content of charger REG0x2A_Fault_Mask Register

2B - REG0x2B_ADC_Control Register

request: 01 2B

response: 01 BB

BB - 1 byte. Content of charger REG0x2B_ADC_Control Register

2C - REG0x2C_ADC_Channel_Control Register

request: 01 2C

response: 01 BB

BB - 1 byte. Content of charger REG0x2C_ADC_Channel_Control Register

2D - REG0x2D_IAC_ADC Register

request: 01 2D

response: 02 BBBB

BBBB - 2 bytes. Content of charger REG0x2D_IAC_ADC Register

2F - REG0x2F_IBAT_ADC Register

request: 01 2F

response: 02 BBBB

BBBB - 2 bytes. Content of charger REG0x2F_IBAT_ADC Register

31 - REG0x31_VAC_ADC Register

request: 01 31

response: 02 BBBB

BBBB - 2 bytes. Content of charger REG0x31_VAC_ADC Register

33 - REG0x33_VBAT_ADC Register

request: 01 33

response: 02 BBBB

BBBB - 2 bytes. Content of charger REG0x33_VBAT_ADC Register

37 - REG0x37_TS_ADC Register

request: 01 37

response: 02 BBBB

BBBB - 2 bytes. Content of charger REG0x37_TS_ADC Register

39 - REG0x39_VFB_ADC Register

request: 01 39

response: 02 BBBB

BBBB - 2 bytes. Content of charger REG0x39_VFB_ADC Register

3B - REG0x3B_Gate_Driver_Strength_Control Register

request: 01 3B

response: 01 BB

BB - 1 byte. Content of charger REG0x3B_Gate_Driver_Strength_Control Register

3C - REG0x3C_Gate_Driver_Dead_Time_Control Register

request: 01 3C

response: 01 BB

BB - 1 byte. Content of charger REG0x3C_Gate_Driver_Dead_Time_Control Register

3D - REG0x3D_Part_Information Register

request: 01 3D

response: 01 BB

BB - 1 byte. Content of charger REG0x3D_Part_Information Register

62 - REG0x62_Reverse_Mode_Battery_Discharge_Current Register

request: 01 62

response: 01 BB

BB - 1 byte. Content of charger REG0x62_Reverse_Mode_Battery_Discharge_Current Register

11 Charger registers write

response in case of command error: 00

response in case of command success: 01 01

Multibit numbers LSB first

00 - REG0x00_Charge_Voltage_Limit Register

request: 11 00 BBBB

BBBB - 2 bytes. New content of charger REG0x00_Charge_Voltage_Limit Register

02 - REG0x02_Charge_Current_Limit Register

request: 11 02 BBBB

BBBB - 2 bytes. New content of charger REG0x02_Charge_Current_Limit Register

06 - REG0x06_Input_Current_DPM_Limit Register

request: 11 06 BBBB

BBBB - 2 bytes. New content of charger REG0x06_Input_Current_DPM_Limit Register

08 - REG0x08_Input_Voltage_DPM_Limit Register

request: 11 08 BBBB

BBBB - 2 bytes. New content of charger REG0x08_Input_Voltage_DPM_Limit Register

0A - REG0x0A_Reverse_Mode_Input_Current_Limit Register

request: 11 0A BBBB

BBBB - 2 bytes. New content of charger REG0x0A_Reverse_Mode_Input_Current_Limit Register

0C - REG0x0C_Reverse_Mode_Input_Voltage_Limit Register

request: 11 0C BBBB

BBBB - 2 bytes. New content of charger REG0x0C_Reverse_Mode_Input_Voltage_Limit Register

10 - REG0x10_Precharge_Current_Limit Register

request: 11 10 BBBB

BBBB - 2 bytes. New content of charger REG0x10_Precharge_Current_Limit Register

12 - REG0x12_Termination_Current_Limit Register

request: 11 12 BBBB

BBBB - 2 bytes. New content of charger REG0x12_Termination_Current_Limit Register

14 - REG0x14_Precharge_and_Termination_Control Register

request: 11 14 BB

BB - 1 byte. New content of charger REG0x14_Precharge_and_Termination_Control Register

15 - REG0x15_Timer_Control Register

request: 11 15 BB

BB - 1 byte. New content of charger REG0x15_Timer_Control Register

- 16 - REG0x16_ThreeStage_Charge_Control Register
request: 11 16 BB
BB - 1 byte. New content of charger REG0x16_ThreeStage_Charge_Control Register
- 17 - REG0x17_Charger_Control Register
request: 11 17 BB
BB - 1 byte. New content of charger REG0x17_Charger_Control Register
- 18 - REG0x18_Pin_Control Register
request: 11 18 BB
BB - 1 byte. New content of charger REG0x18_Pin_Control Register
- 19 - REG0x19_Power_Path_and_Reverse_Mode_Control Register
request: 11 19 BB
BB - 1 byte. New content of charger REG0x19_Power_Path_and_Reverse_Mode_Control Register
- 1A - REG0x1A_MPPT_Control Register
request: 11 1A BB
BB - 1 byte. New content of charger REG0x1A_MPPT_Control Register
- 1B - REG0x1B_TS_Charging_Threshold_Control Register
request: 11 1B BB
BB - 1 byte. New content of charger REG0x1B_TS_Charging_Threshold_Control Register
- 1C - REG0x1C_TS_Charging_Region_Behavior_Control Register
request: 11 1C BB
BB - 1 byte. New content of charger REG0x1C_TS_Charging_Region_Behavior_Control Register
- 1D - REG0x1D_TS_Reverse_Mode_Threshold_Control Register
request: 11 1D BB
BB - 1 byte. New content of charger REG0x1D_TS_Reverse_Mode_Threshold_Control Register
- 1E - REG0x1E_Reverse_Undervoltage_Control Register
request: 11 1E BB
BB - 1 byte. New content of charger REG0x1E_Reverse_Undervoltage_Control Register
- 28 - REG0x28_Charger_Mask_1 Register
request: 11 28 BB
BB - 1 byte. New content of charger REG0x28_Charger_Mask_1 Register
- 29 - REG0x29_Charger_Mask_2 Register
request: 11 29 BB
BB - 1 byte. New content of charger REG0x29_Charger_Mask_2 Register
- 2A - REG0x2A_Fault_Mask Register
request: 11 2A BB

BB - 1 byte. New content of charger REG0x2A_Fault_Mask Register

2B - REG0x2B_ADC_Control Register

request: 11 2B BB

BB - 1 byte. New content of charger REG0x2B_ADC_Control Register

2C - REG0x2C_ADC_Channel_Control Register

request: 11 2C BB

BB - 1 byte. New content of charger REG0x2C_ADC_Channel_Control Register

3B - REG0x3B_Gate_Driver_Strength_Control Register

request: 11 3B BB

BB - 1 byte. New content of charger REG0x3B_Gate_Driver_Strength_Control Register

3C - REG0x3C_Gate_Driver_Dead_Time_Control Register

request: 11 3C BB

BB - 1 byte. New content of charger REG0x3C_Gate_Driver_Dead_Time_Control Register

62 - REG0x62_Reverse_Mode_Battery_Discharge_Current Register

request: 11 62 BB

BB - 1 byte. New content of charger REG0x62_Reverse_Mode_Battery_Discharge_Current Register

04 Gauge ManufacturerAccess read

response in case of command error: 00

Multibit numbers LSB first

0001 - 0x0001 Device Type

request: 04 01 00

response: CC bbb...

CC - 1 byte. Number of following bytes

bbb... - byte(0) ... byte(CC-1)

0002 - 0x0002 Firmware Version

0003 - 0x0003 Hardware Version

0004 - 0x0004 Instruction Flash Signature

0005 - 0x0005 Static DF Signature

0006 - 0x0006 Chemical ID

0008 - 0x0008 Static Chem DF Signature

0050 - 0x0050 SafetyAlert

0051 - 0x0051 SafetyStatus

0052 - 0x0052 PFAAlert

0053 - 0x0053 PFStatus

0054 - 0x0054 OperationStatus

0055 - 0x0055 ChargingStatus

0056 - 0x0056 GaugingStatus

0057 - 0x0057 ManufacturingStatus



0058 - 0x0058 AFESStatus
0059 - 0x0059 AFESConfig
005A - 0x005A AFEVCx
005B - 0x005B AFEData
0060 - 0x0060 Lifetime Data Block 1
0061 - 0x0061 Lifetime Data Block 2
0062 - 0x0062 Lifetime Data Block 3
0063 - 0x0063 Lifetime Data Block 4
0064 - 0x0064 Lifetime Data Block 5
0065 - 0x0065 Lifetime Data Block 6
0066 - 0x0066 Lifetime Data Block 7
0070 - 0x0070 ManufacturerInfo
0071 - 0x0071 DStatus1
0072 - 0x0072 DStatus2
0080 - 0x0080 CUV Snapshot
0081 - 0x0081 COV Snapshot

14 Gauge ManufacturerAccess write
response in case of command error: 00
response in case of command success: 01 01
Multibit numbers LSB first

0010 - 0x0010 SHUTDOWN Mode - Execute SHUTDOWN Mode command
request: 14 10 00

0011 - 0x0011 SLEEP Mode
001B - 0x001B Cell Balance Toggle
001C - 0x001C AFE Delay Disable
001D - 0x001D SAFE Toggle
001E - 0x001E PRE-CHG FET
001F - 0x001F CHG FET
0020 - 0x0020 DSG FET
0022 - 0x0022 FET Control
0023 - 0x0023 Lifetime Data Collection
0024 - 0x0024 Permanent Failure
0025 - 0x0025 Black Box Recorder
0026 - 0x0026 SAFE
0027 - 0x0027 LED Display Enable
0028 - 0x0028 Lifetime Data Reset
0029 - 0x0029 Permanent Fail Data Reset
002A - 0x002A Black Box Recorder Reset
002B - 0x002B LED TOGGLE
002C - 0x002C LED Display Press
002D - 0x002D CALIBRATION Mode
0041 - 0x0041 Device Reset
0F00 - 0x0F00 ROM Mode



F080 - 0xF080 Exit Calibration Output Mode
F081 - 0xF081 OutputCellVoltageforCalibration
F082 - 0xF082 OutputCellVoltageCCandTempforCalibration

05 Gauge SBS Command read

response in case of command error: 00
Multibit numbers LSB first

01 - 0x01 RemainingCapacityAlarm()

request: 05 01

response: CC bbb...

CC - 1 byte. Number of following bytes

bbb... - byte(0) ... byte(CC-1)

02 - 0x02 RemainingTimeAlarm()

03 - 0x03 BatteryMode()

04 - 0x04 AtRate()

05 - 0x05 AtRateTimeToFull()

06 - 0x06 AtRateTimeToEmpty()

07 - 0x07 AtRateOK()

08 - 0x08 Temperature()

09 - 0x09 Voltage()

0A - 0x0A Current()

0B - 0x0B AverageCurrent()

0C - 0x0C MaxError()

0D - 0x0D RelativeStateOfCharge()

0E - 0x0E AbsoluteStateOfCharge()

0F - 0x0F RemainingCapacity()

10 - 0x10 FullChargeCapacity()

11 - 0x11 RunTimeToEmpty()

12 - 0x12 AverageTimeToEmpty()

13 - 0x13 AverageTimeToFull()

14 - 0x14 ChargingCurrent()

15 - 0x15 ChargingVoltage()

16 - 0x16 BatteryStatus()

17 - 0x17 CycleCount()

18 - 0x18 DesignCapacity()

19 - 0x19 DesignVoltage()

1A - 0x1A SpecificationInfo()

1B - 0x1B ManufacturerDate()

1C - 0x1C SerialNumber()

20 - 0x20 ManufacturerName()

21 - 0x21 DeviceName()

22 - 0x22 DeviceChemistry()

23 - 0x23 ManufacturerData()/CalibrationData()

2B - 0x2B HostFETControl



2C - 0x2C GPIOStatus
2D - 0x2D GPIOControl
2E - 0x2E VAUXVoltage()
3B - 0x3B CellVoltage5
3C - 0x3C CellVoltage4
3D - 0x3D CellVoltage3
3E - 0x3E CellVoltage2
3F - 0x3F CellVoltage1
4C - 0x4C DynamicPower()
4D - 0x4D ExtAveCellVoltage()
4E - 0x4E PendingEDV()
4F - 0x4F StateOfHealth (SOH)
50 - 0x50 SafetyAlert
51 - 0x51 SafetyStatus
52 - 0x52 PFAlert
53 - 0x53 PFStatus
54 - 0x54 OperationStatus
55 - 0x55 ChargingStatus
56 - 0x56 GaugingStatus
57 - 0x57 ManufacturingStatus
58 - 0x58 AFESStatus
59 - 0x59 AFESConfig
5A - 0x5A AFEVCx
5B - 0x5B AFEDData
60 - 0x60 Lifetime Data Block 1
61 - 0x61 Lifetime Data Block 2
62 - 0x62 Lifetime Data Block 3
63 - 0x63 Lifetime Data Block 4
64 - 0x64 Lifetime Data Block 5
65 - 0x65 Lifetime Data Block 6
66 - 0x66 Lifetime Data Block 7
70 - 0x70 ManufacturerInfo
71 - 0x71 DASTatus1
72 - 0x72 DASTatus2
80 - 0x80 CUV Snapshot
81 - 0x81 COV Snapshot

15 Gauge SBS Command write

response in case of command error: 00

response in case of command success: 01 01

Multibit numbers LSB first

01 - 0x01 RemainingCapacityAlarm() - Set new value of RemainingCapacityAlarm

request: 15 01 BBBB

BBBB - 2 bytes. New value

02 - 0x02 RemainingTimeAlarm()

03 - 0x03 BatteryMode()

04 - 0x04 AtRate()

17 - 0x17 CycleCount()

18 - 0x18 DesignCapacity()

19 - 0x19 DesignVoltage()

1A - 0x1A SpecificationInfo()

1B - 0x1B ManufacturerDate()

1C - 0x1C SerialNumber()

2B - 0x2B HostFETControl

2D - 0x2D GPIOControl

06 Gauge flash read

response in case of command error: 00

Flash address - LSB first

request: 06 AAAA

AAAA - 2 bytes. Flash address, must be in range 0x4000–0x5FFF

response: CCbbb...

CC - 1 byte. Number of following bytes

bbb... - byte(0) ... byte(CC-1)

16 Gauge flash write

response in case of command error: 00

response in case of command success: 01 01

Flash address - LSB first

request: 06 AAAA CC bbb...

AAAA - 2 bytes. Flash address, must be in range 0x4000–0x5FFF

CC - 1 byte. Number of following bytes

bbb... - byte(0) ... byte(CC-1)