

Tynemouth Software

PET IEEE-488 DIAGNOSTICS BUILD INSTRUCTIONS

MAIN BOARD

PARTS

- 1 x PET IEEE-488 Diagnostics PCB
- 1 x 24 way 0.156" edge connector (pins or solder tabs)
- 2 x 100nF axial capacitor
- 16 x 1K Resistor
- 8 x 5mm Red LED
- 8 x 5mm Green LED
- 2 x 74HCT245
- 1 x pin header (2 x 18 pin, 0.1")
- 1 x right angle header pin

ASSEMBLY

Start with the resistors and capacitors, then the driver chips, LEDs and connectors. The LEDs should be installed matching the footprint on the PCB. The cathode (negative) lead is the shorter one, and corresponds to the flat on the case. Fit the right angle pin into the pin marked +5V. The pin next to it (which is ground) can be ignored if powering the board from the PET datasette connector as ground is supplied through the IEEE-488 bus connector. Finally solder on the edge connectors, at the end nearest the driver chips and the optional pin header for logic analyser connections.

POWER BOARD

PARTS

- 1 x PET Datasette power PCB
- 1 x 12 way 0.156" edge connector (pins or solder tabs)
- 1 piece of wire

ASSEMBLY

Solder on the edge connector to the side marked 'computer'. The wire should be attached to the pin marked +. The wire can be threaded through the extra holes in the board to provide a strain relief. Cut it a suitable length to reach the pin on the side of the IEEE-488 board.

Tynemouth Software

COMPONENT PLACEMENT

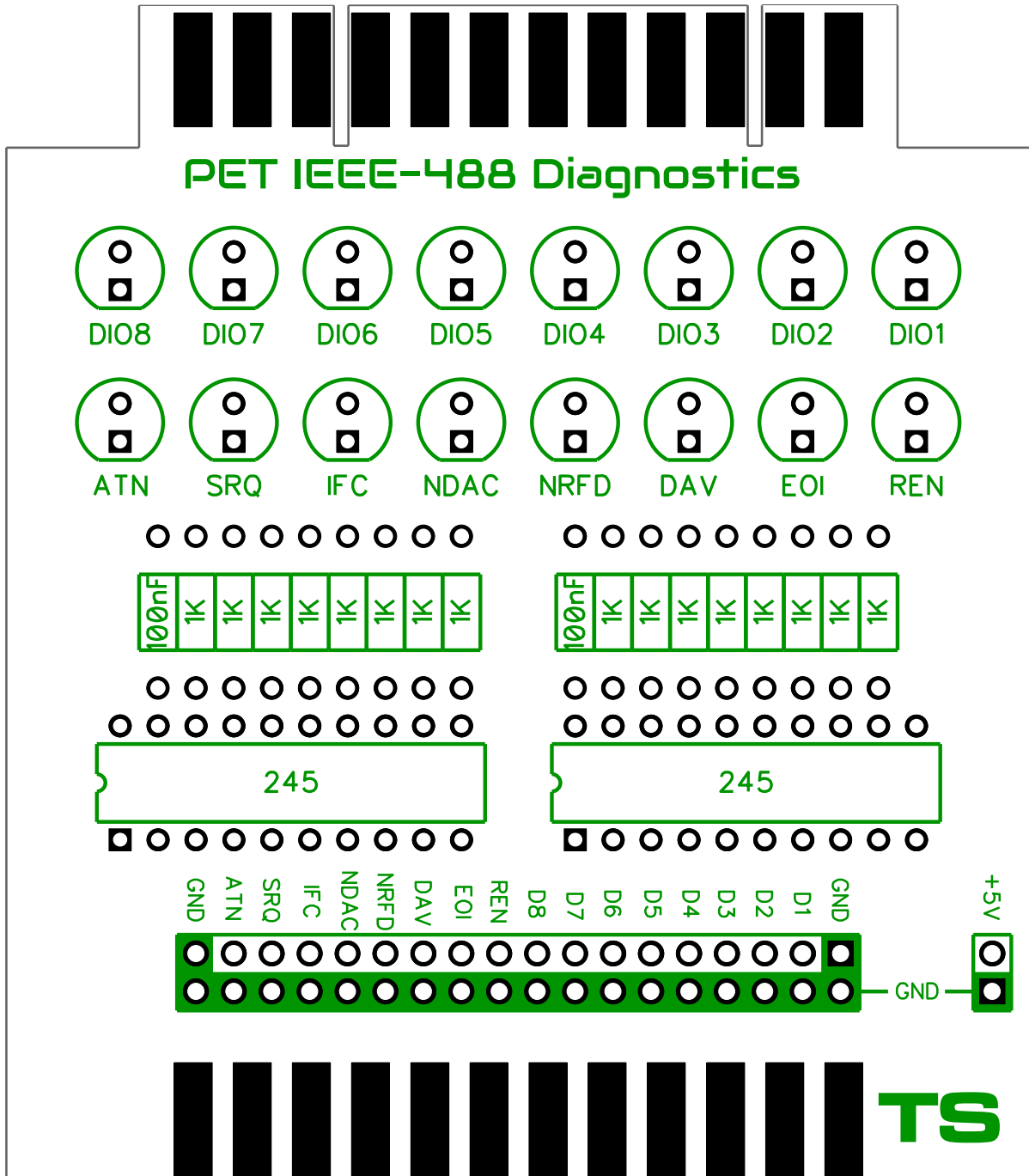

Tynemouth Software

SCHEMATIC

There are three connectors wired in parallel to the IEEE-488 bus. The PET bus connector, the pass through at the top and the debug pin header.

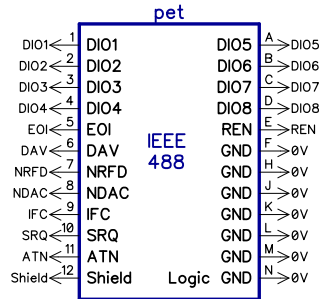

Ground pins are provided for each signal on the debug header, with extras at each side, so a single row connector could be used if preferred.

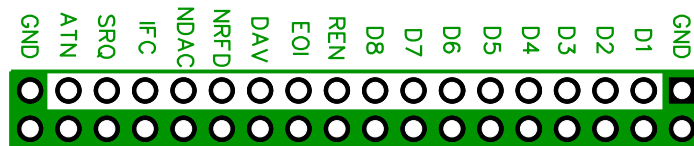

The LEDs are driven from two 74HCT245 buffer chips. The inputs levels of these chips line up with the IEEE-488 bus specification, which is 3V logic. The input stages put a very small load on the bus so as not to affect the signalling. The HCT chips have strong output stages, so have no problem driving the LEDs directly.

The LEDs are arranged so the light when the output is low, so they show when signals on the bus are active (low).

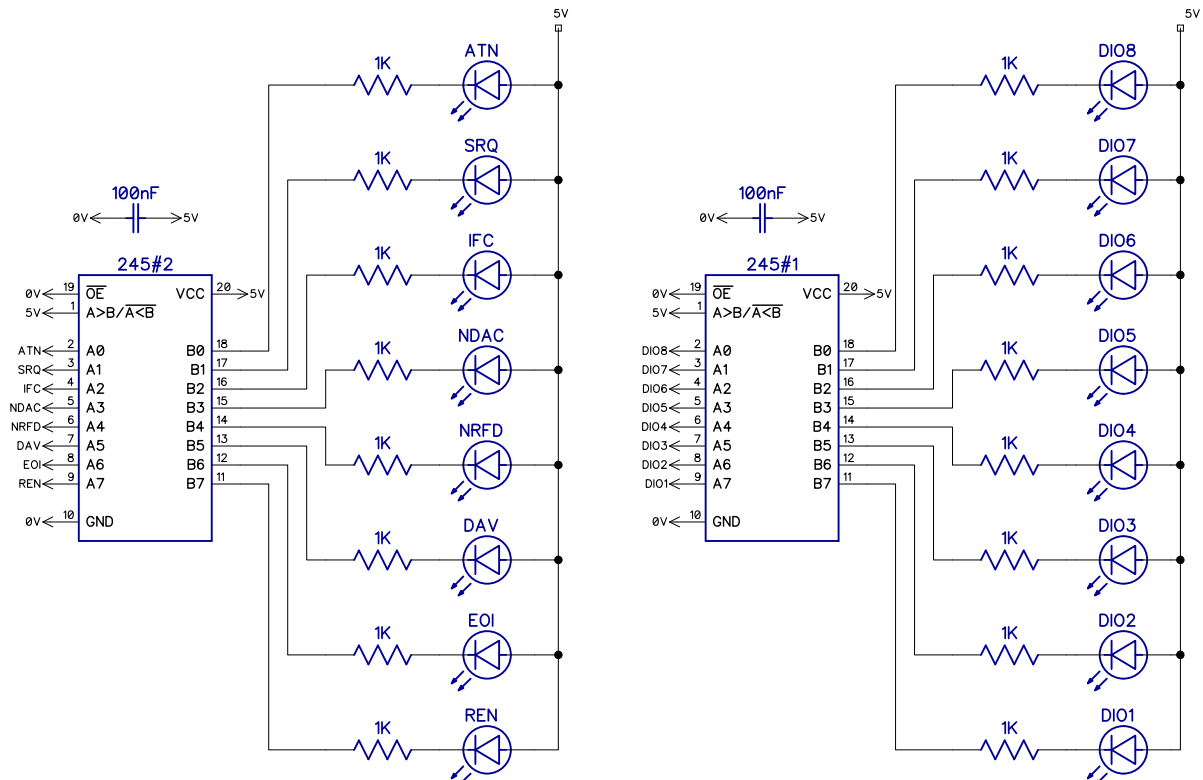

Tynemouth Software

PET IEEE-488 DIAGNOSTICS USAGE

The signals on the IEEE-488 bus are generated from several sources inside the PET. There are two connections for most pin on the bus. One is the write signal, to drive the bus; the other reads the bus signal.

Signal	Read	Write
DIO1-DIO8	PIA#1 PA0-PA7	PIA#1 PB0-PB7
EOI	PIA#2 PA6	PIA#2 CA2
DAV	VIA PB7	PIA#1 CB2
NRFD	VIA PB6	VIA PB1
NDAC	VIA PB0	PIA#1 CA2
IFC	N/C	Reset buffered through 7417
SRQ	PIA#1 CB1	N/C
ATN	PIA#2 CA1	VIA PB2
REN	N/C	0V (permanently asserted)

REN is wired to 0V on all PETs, so will always be active, and serves as a power indicator. SRQ is input only, and IFC (reset) is output only.

An IEEE-488 bus pin has two states; normally it is 'released' and will float high. No device will drive the bus high, there are pull up resistors in each device on the bus to allow the signal to float high when no device is driving the bus. When a device wants to 'assert' a signal, it pulls it low. The LEDs show bus activity, and will be lit when the signals are asserted (low). In normal released state (floating high), the LEDs are of.

State	Voltage on pins	LED state
Normal / Released	> 2V	Off
Active / Asserted	< 1V	On

To test these, various PEEKs and POKEs can be used to alter pin states and see if they change. If poking a value causes the LED to change, the writing pin is working, if it is read back correctly, then the reading is working.

Pin	Write 0 (Assert)	Write 1 (Release)	Read value
DIO1-DIO8	POKE 59426,0	POKE 59426,255	PRINT PEEK(59424)
EOI	POKE 59409,52	POKE 59409,60	PRINT PEEK(59408)
DAV	POKE 59427,52	POKE 59427,60	PRINT PEEK(59456)
NRFD	POKE 59456,253	POKE 59456,255	PRINT PEEK(59456)
NDAC	POKE 59425,52	POKE 59425,60	PRINT PEEK(59456)
ATN	POKE 59456,251	POKE 59456,255	PRINT PEEK(59425)