

Wi-Fi Module

MS14SF1

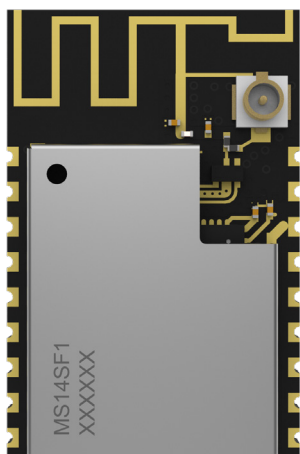

Datasheet

V 1.0.0



Version Note

Version	Details	Contributor(s)	Date	Notes
1.0.0	First edit	Vincle, Leo	2024.07.08	

Part Number

Model	Hardware Code
MS14SF1	1N02AI

Click the icon to view and download the latest product documents electronically.
https://en.minewsemi.com/file/MS14SF1-nRF7002_Datasheet_K_EN.pdf



MS14SF1-nRF7002

Low-power, Dual-band 2.4&5G Wi-Fi 6, Support TWT, Support STA/AP Mode

The MS14SF1 is a low-power, cost-effective wireless WiFi 6 module based on nRF7002. It integrates 2.4G and 5.8G dual-band 1T1R transceiver and LNA, as well as other powerful supporting development resources to provide a perfect solution for WiFi connection. The module has optional onboard antenna and IPEX external antenna, supports WPA/WPA2/WPA3 encryption, supports STA/AP mode, and has a transmission distance of 80M in office environment, which can meet the needs of various structural scenarios.

FEATURES



Wi-Fi 6
Low power



High
Cost-effective



Dual-band
2.4G + 5G, 1T1R



Support optional
external antenna



Support TWT



Support STA/AP
Mode



Transmission
distance in office
environment:
80M

KEY PARAMETER

MS14SF1

Chip Model	nRF7002	Antenna	PCB/IPEX
Module Size	22.9×15×3mm	Firmware	None
Receiving Sensitivity	-98.6dBm	Transmission Power	Maximum +21dBm
Current(TX)	191mA - 2.4G 260mA - 5G	Current(RX)	60mA - 2.4G 56mA - 5G

APPLICATION



Smart
Buildings



Consumer
Electronics



Smart
Healthcare



Security
Equipment



Automotive
Devices



Smart
Agriculture



INDEX

1.Block Diagram	05
2.Electrical Specification	05
3.Pin Description	06
4.Pin Definition	06
5.Mechanical Drawing	07
6.Electrical Schematic	07
7.Connection Diagram	08
8.PCB Layout	08
9.Reflow and Soldering.....	09
10.Package Information.....	10
11.Storage Conditions	11
12.Handling Conditions.....	11
13.Quality	11
14.Copyright Statement.....	12
15.Related Documents	12

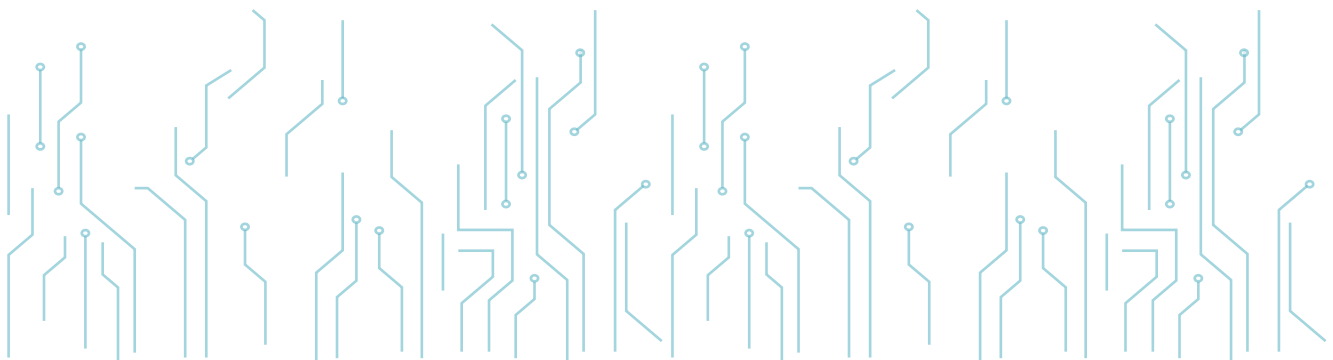

1 BLOCK DIAGRAM

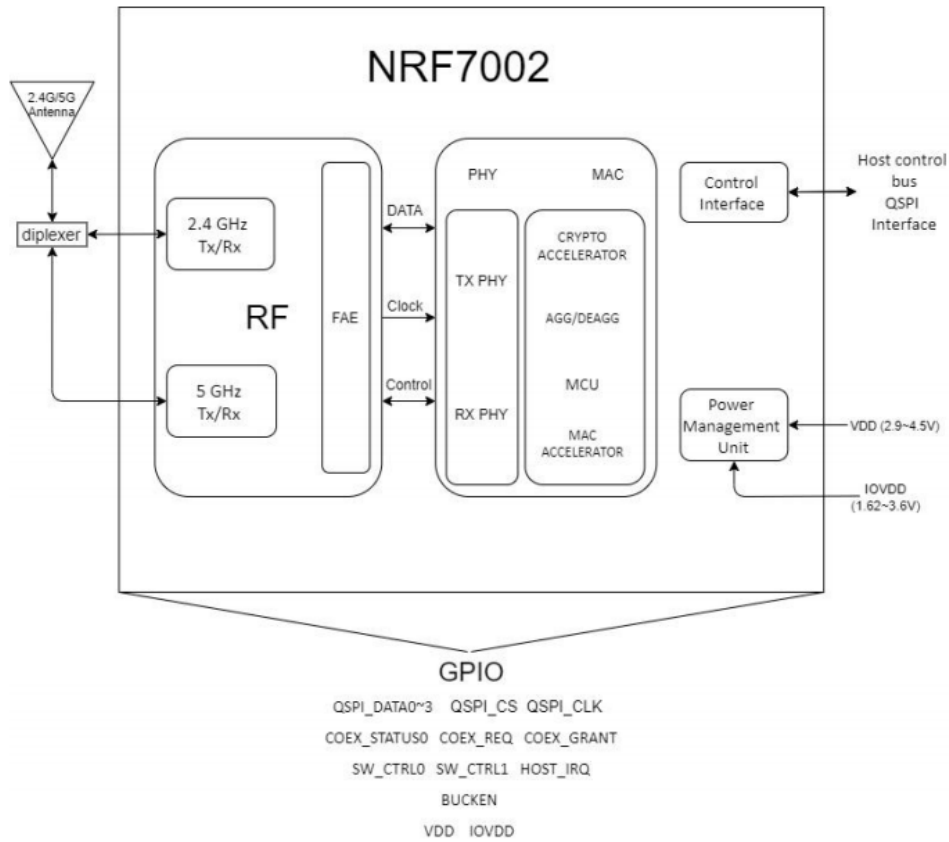

2 ELECTRICAL SPECIFICATION

Parameter	Values	Notes
Operating Voltage	2.9V-4.5V	To ensure RF work, supply voltage suggest not lower than 3.6V
Operating Temperature	-40℃~+85℃	Storage temperature is -40℃~+125℃
Transmission Power	Maximum +21dBm	Configurable
Current(RX)	2.4G - 60mA 5G - 56mA	Maximum output power
Current(TX)	2.4G - 191mA 5G - 260mA	Maximum output power
Module Dimension	22.9*15*3mm	
Quantity of IO Port	13	QSPI, SPI

3 PIN DESCRIPTION

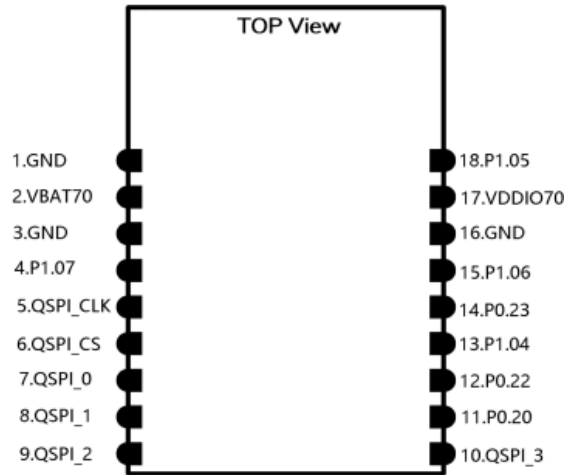



4 PIN DEFINITION

Pin Number	Symbol	Definition
VBAT70	Positive power supply	Power supply, 2.5V-5.5V, with this pin, and recommended voltage 3.6V
VDDIO70	Power	VDD IO Power supply 1.8V
GND	Ground	Negative power supply
P0.20	Digital I/O	Coex interface: COEX_STATUS0
P0.22	Digital I/O	Coex interface: COEX_REQ
P0.23	Digital I/O	SW_CTRL0: External switch control
P1.04	Digital I/O	Coex interface: COEX_GRANT
P1.05	Digital I/O	HOST_IRQ: Host processor interrupt request
P1.06	Digital I/O	SW_CTRL1: External switch control
P1.07	Digital I/O	BUCKEN: PWR IP enable pin
QSPI_CLK	Digital I/O	QSPI clock
QSPI_CS	Digital I/O	QSPI Slave select (CS)
QSPI_0	Digital I/O	QSPI data
QSPI_1	Digital I/O	QSPI data
QSPI_2	Digital I/O	QSPI data
QSPI_3	Digital I/O	QSPI data

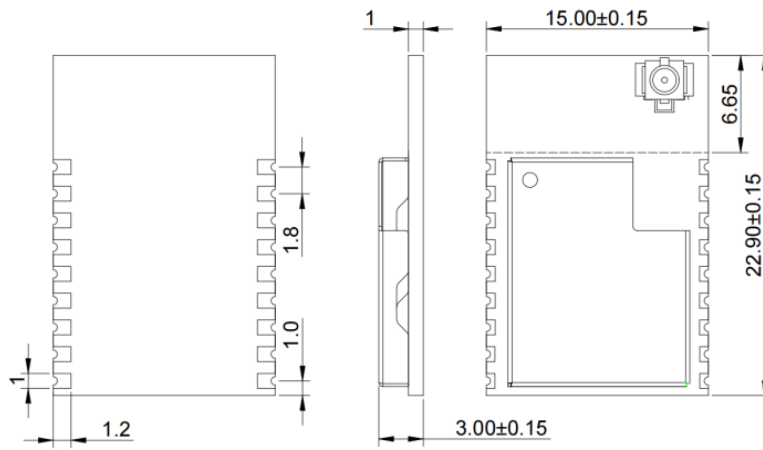
5 MECHANICAL DRAWING



 Default unit: mm Default tolerance: ±0.15

 Notice: The recommended pad size is 1.2*1.0mm with a pad extension of 0.5mm

6 ELECTRICAL SCHEMATIC

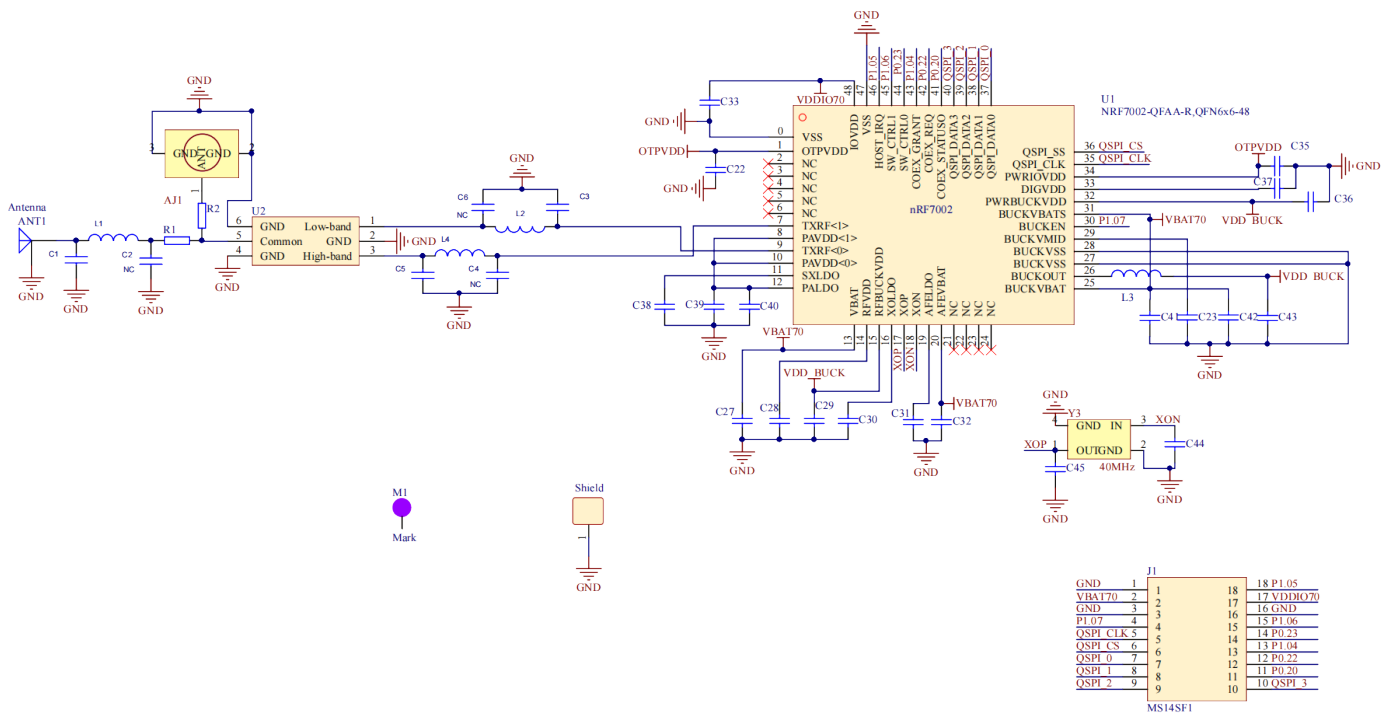

 Notice: Before placing an order, please confirm the specific configuration required with the salesperson.

7 CONNECTION DIAGRAM

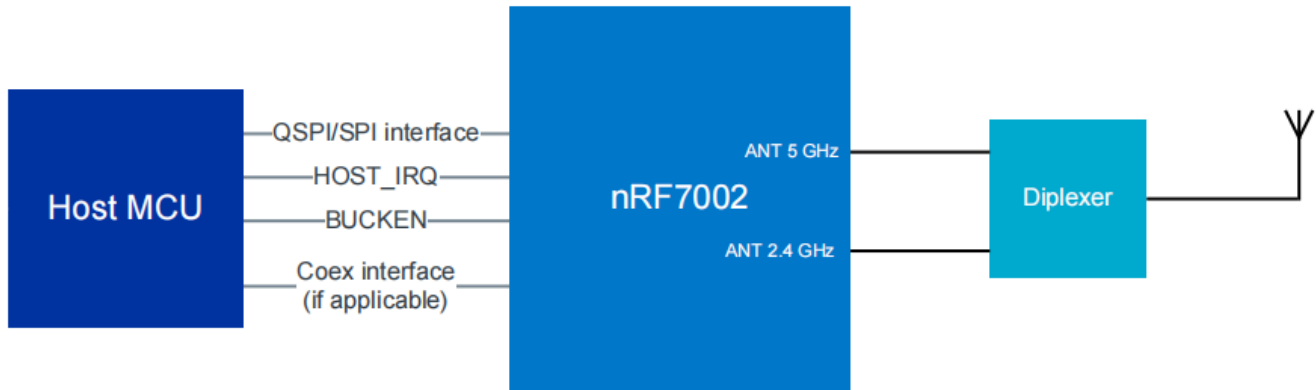

8 PCB LAYOUT

Module antenna area couldn't have GND plane or metal cross line, couldn't place components nearby. It is better to make hollow out or clearance treatment or place it on the edge of PCB board.

 Refer to examples as below, and highly suggest to use the first design and the adjustment of modules antenna design according to the first wiring.

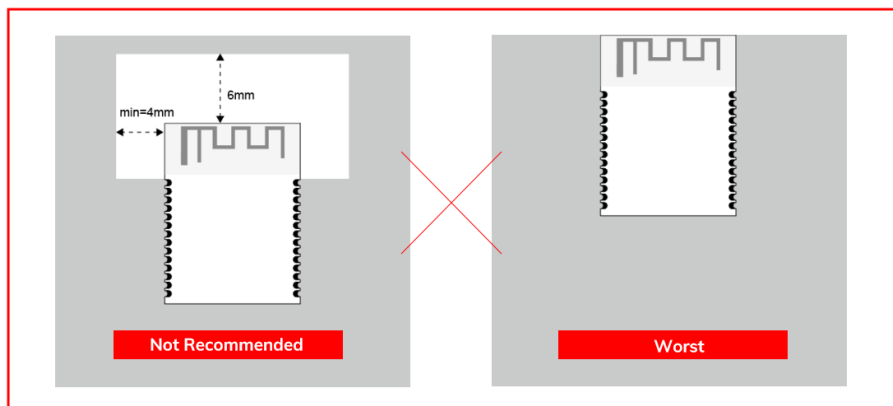
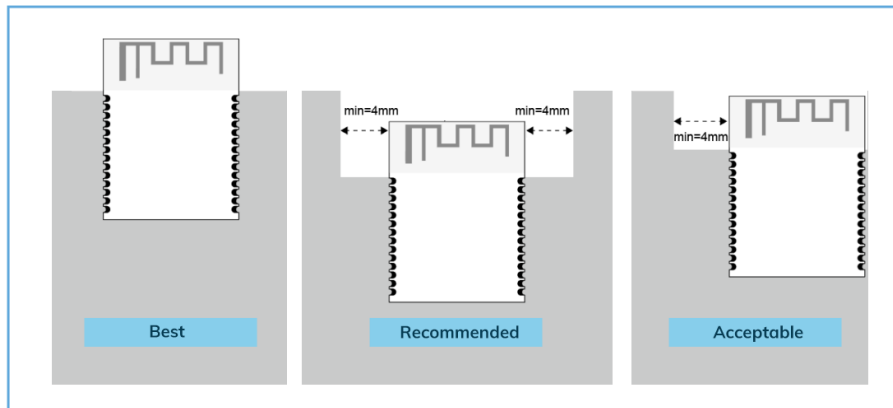

Layout Notes :

- 1) Preferred Module antenna area completely clearance and not be prevented by metals, otherwise it will influence antenna's effect (as above DWG. indication).
- 2) Cover the external part of module antenna area with copper as far as possible to reduce the main board's signal cable and other disturbing.
- 3) It is preferred to have a clearance area of 4 square meter or more area around the module antenna (including the shell) to reduce the influence to antenna.
- 4) Device should be grounded well to reduce the parasitic inductance.
- 5) Do not cover copper under module's antenna in order to avoid affect signal radiation or lead to transmission distance affected.
- 6) Antenna should keep far from other circuits to prevent radiation efficiency reduction or affects the normal operation of other lines.
- 7) Module should be placed on edge of circuit board and keep a distance away from other circuits.
- 8) Suggesting to use magnetic beads to insulate module's access power supply.

9 REFLOW AND SOLDERING

- 1) Do SMT according to above reflow oven temperature deal curve. Max. Temperature is 260°C; Refer to IPC/JEDEC standard; Peak TEMP<260°C; Times: ≤2 times, suggest only do once reflow soldering on module surface in case of SMT double pad involved. Contact us if special crafts involved.

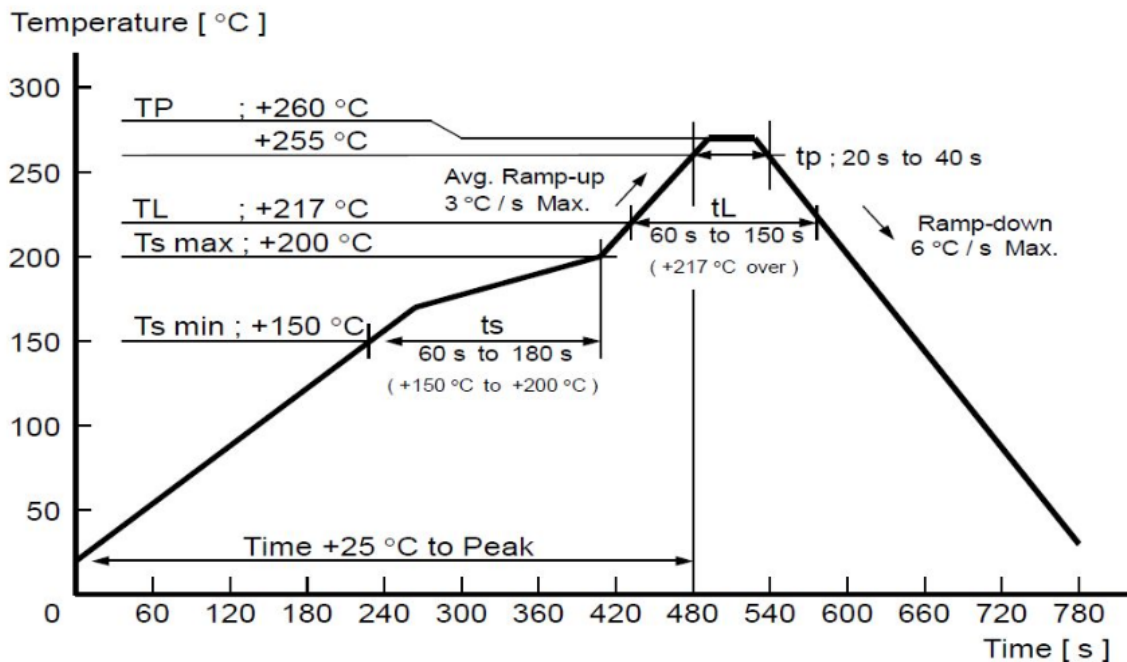



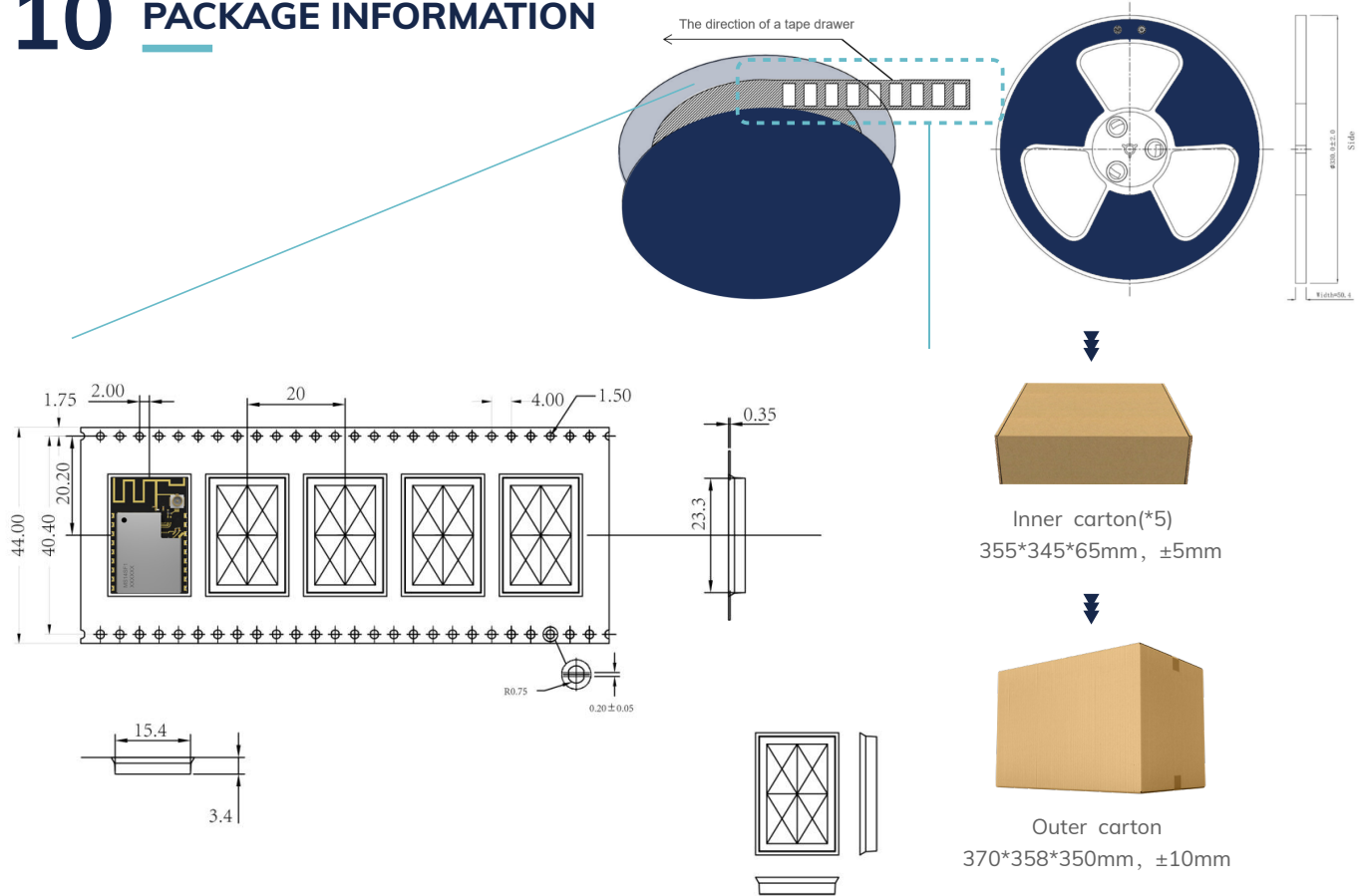

- 2) Suggesting to make 0.2mm thickness of module SMT for partial ladder steel mesh, then make the opening extend 0.8mm
- 3) After unsealing, it cannot be used up at one time, should be vacuumed for storage, couldn't be exposed in the air for long time. Please avoid getting damp and soldering-pan oxidizing. If there are 7 to 30 days interval before using online SMT, suggest to bake at 65-70 °C for 24 hours without disassembling the tape.
- 4) Before using SMT, please adopt ESD protection measure.

10 PACKAGE INFORMATION

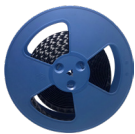
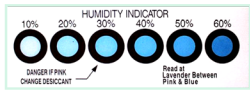

Remarks

General material list for FCL packaging:

			
Carrier tape packaging tray	Humidity Indicator (1 pcs/bag)	Desiccant (placed in a vacuum bag)	Vacuum bag
		Other:	
Inner carton(*5) 355*345*65mm, ±5mm	Outer carton 370*358*350mm, ±10mm	Moisture-proof label (attached to the vacuum bag)	
		Certification label (attached to the vacuum bag)	
		Outer box label	

 Default unit: mm Default tolerance: ±0.1

Packing detail	Specification	Net weight	Gross weight	Dimension
MS14SF1	900PCS	-	-	W=44mm, T=0.35mm

 Note: Default weight tolerance all are within 10g (except the special notes)

11 STORAGE CONDITIONS

- **Please use this product within 6 months after signing the receipt.**
 - This product should be stored without opening the package at an ambient temperature of 5~35°C and a humidity of 20~70%RH.
 - This product should be left for more than 6 months after receipt and should be confirmed before use.
 - The product must be stored in a non-corrosive gas (Cl₂, NH₃, SO₂, NO_x, etc.).
 - To avoid damaging the packaging material, do not apply any excessive mechanical shocks, including but not limited to sharp objects adhering to the packaging material and product dropping.
- **This product is suitable for MSL2 (based on JEDEC standard J-STD-020).**
 - After opening the package, the product must be stored at ≤30°C/<60%RH. It is recommended to use the product within 3-6 months after opening the package.
 - When the color of the indicator in the package changes, the product should be baked before welding.
- **Baking is not required for one year if exposure is limited to <30°C and 60%RH. Refer to MSL2 for exposure criteria for moisture sensitivity level. If exposed to (≥168h@85°C/60%RH) conditions or stored for more than one year, recommended baking conditions.**
 1. 120 +5/-5°C, 8 hours, 1 time
Products must be baked individually on heat-resistant trays because the materials (base tape, reel tape, and cover tape) are not heat-resistant, and the packaging material may be deformed at temperatures of 120°C;
 2. 90°C +8/-0°C, 24hours, 1times
The base tape can be baked together with the product at this temperature. Please pay attention to the uniformity of heat.

12 HANDLING CONDITIONS

- Be careful in handling or transporting products because excessive stress or mechanical shock may break products.
- Handle with care if products may have cracks or damages on their terminals. If there is any such damage, the characteristics of products may change. Do not touch products with bare hands that may result in poor solder ability and destroy by static electrical charge.

13 QUALITY

Cognizant of our commitment to quality, we operate our own factory equipped with state-of-the-art production facilities and a meticulous quality management system. We hold certifications for ISO9001, ISO14001, ISO27001, OHSAS18001, BSCI.

Every product undergoes stringent testing, including transmit power, sensitivity, power consumption, stability, and aging tests. Our fully automated module production line is now in full operation, boasting a production capacity in the millions, capable of meeting high-volume production demands.

14 COPYRIGHT STATEMENT

This manual and all the contents contained in it are owned by Shenzhen Minewsemi Co., Ltd. and are protected by Chinese laws and applicable international conventions related to copyright laws.

The certified trademarks included in this product and related documents have been licensed for use by MinewSemi. This includes but is not limited to certifications such as BQB, RoHS, REACH, CE, FCC, BQB, IC, SRRC, TELEC, WPC, RCM, WEEE, etc. The respective textual trademarks and logos belong to their respective owners. For example, the Bluetooth® textual trademark and logo are owned by Bluetooth SIG, Inc. Other trademarks and trade names are those of their respective owners. Due to the small size of the module product, the "®" symbol is omitted from the Bluetooth Primary Trademarks information in compliance with regulations.

The company has the right to change the content of this manual according to the technological development, and the revised version will not be notified otherwise. Without the written permission and authorization of the company, any individual, company, or organization shall not modify the contents of this manual or use part or all of the contents of this manual in other ways. Violators will be held accountable in accordance with the law.

15 RELATED DOCUMENTS

- nRF7002_Chip_Datasheet
https://en.minewsemi.com/file/nRF7002_Chip_Datasheet_EN.pdf
- MinewSemi_Product_Naming_Reference_Manual_V1.0
https://en.minewsemi.com/file/MinewSemi_Product_Naming_Reference_Manual_EN.pdf
- MinewSemi_Connectivity_Module_Catalogue_V2.0
https://en.minewsemi.com/file/MinewSemi_Connectivity_Module_Catalogue_EN.pdf



For product change notifications and regular updates of Minewsemi documentation, please register on our website: www.minewsemi.com

MINEWSEMI



SHENZHEN MINEWSEMI CO., LTD.



0086-755-2801 0353



<https://minewsemi.com>



minewsemi@minew.com



<https://store.minewsemi.com>



No.8, Qinglong Road, Longhua District, Shenzhen, China