

Three GNSS(GPS, GLONASS and BeiDou)
High Precision、 Low Drift、 Low Power

Product Specification

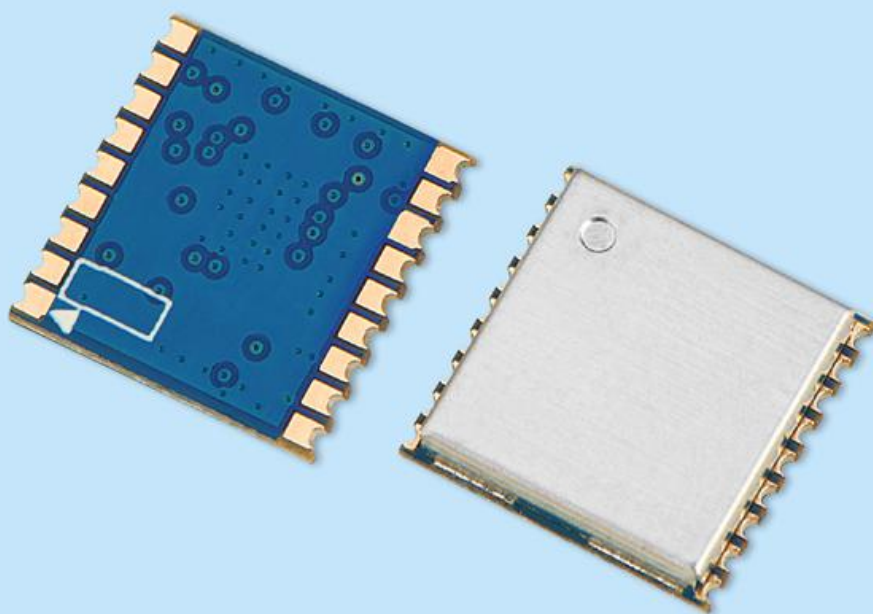

Catalogue

1. Overview	- 3 -
2. Features	- 3 -
3. Applications	- 3 -
4. Typical application circuit	- 3 -
5. Module interface description	- 4 -
6. Performance parameters	- 5 -
7. Typical application circuit	- 6 -
8. Pin definition	- 7 -
9. Recommended antenna index	- 8 -
10. Mechanical size	- 8 -
11. Recommended package	- 9 -
12. Attentions	- 9 -

Note: Revision History

Revision	Date	Comment
V1.0	2022-10	First release
V2.0	2022-11	Description Updated

1. Overview

GPS01-ZK module is a tri-mode GPS module that supports BDS/GPS/GLONASS/QZSS/SBAS and fully supports BeiDou B3, which can provide users with high quality, strong anti-jamming and low-power positioning and navigation solutions.

2. Features

- Support BDS B1/B1C, GPS L1 C/A, GLO L1OF, Gal E1 frequency point
- Support BDS/GPS/GLONASS/Galileo single-mode, dual-mode and multi-mode work, can switch between each other by command, default BDS/GPS/GLO tri-mode work
- Support A-GNSS assisted positioning
- Support power supply to active antenna
- With backup power input interface
- Support hot start
- Support external reset
- Support UART interface
- Cold start capture sensitivity up to -147dBm. Tracking sensitivity up to -163 dBm.

3. Applications

- Personal positioning and navigation products
- Vehicle, ship positioning and navigation
- Internet of Things
- Handheld portable device

4. Typical application circuit

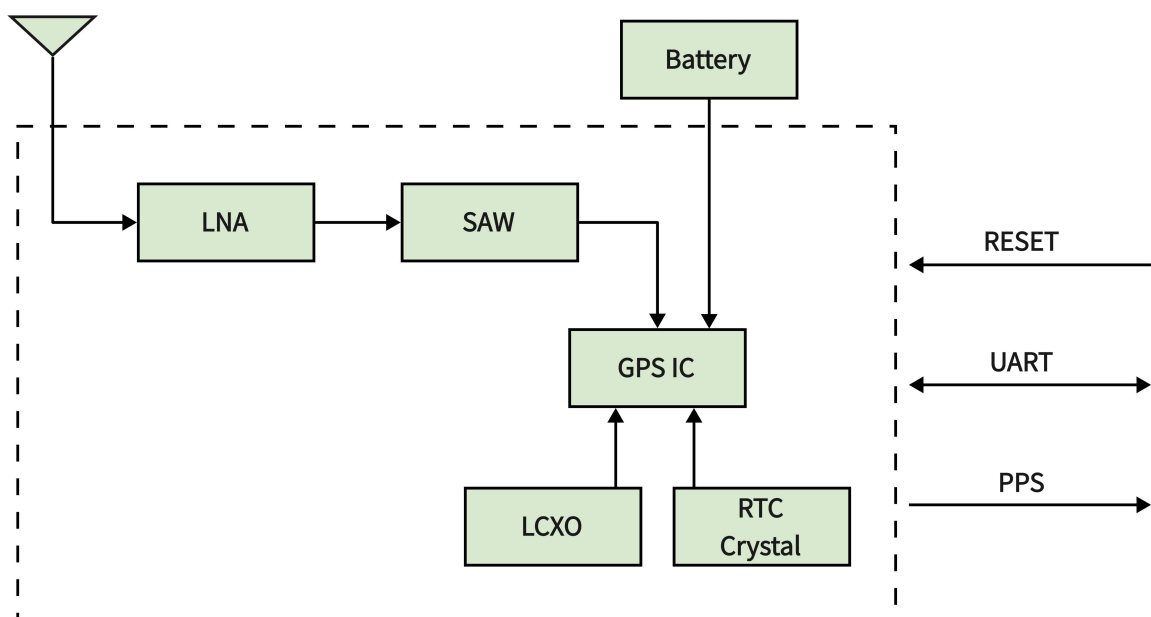

5. Module interface description

1) Power supply

The module has three power input pins (VCC, V_BCKP and VDD_IO) and one power output pin (VCC_RF).

VCC is the main power supply of the module.

VCC_IO is the IO power supply of the module.

V_BCKP : Back up power supply for RTC circuit to ensure that key information is not lost when the main power supply VCC is off.

VCC_RF: 3.3V output , which can be used for antenna or external LNA.

2) Antenna interface

RF_IN of the module can be connected to multi-mode antenna directly. The impedance is 50Ω.

3) Reset interface

The module has built-in power-on reset circuit. The nRESET pin can be left floating if the external reset function is not used; Below is the time chart for external reset function:

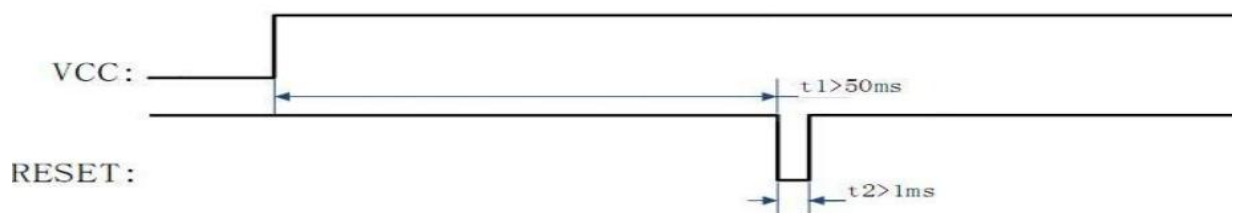

4) 1PPS signal interface

Module 4 pin 1PPS is the second pulse signal output, 1PPS signal needs to be delayed for several seconds after the module achieves positioning before it is output.

5) UART interface

The serial port outputs NMEA data at the UTC second boundary, and the module's working mode and baud rate can be modified by the host computer through the serial port. The range of baud rate is 4800bps ~ 230400bps. The default baud rate is 115200 bps.

The data format is: 1 start bit, 8 data bits, 1 stop bit, no parity bit.

6. Performance parameters

Parameter	Description	Minimum	Typical	Maximum	Unit	Condition
Operating conditions						
Operating voltage range	VCC	3.0	3.3	3.5	V	
	V_BCKP	2.5	3.3	3.5	V	
Temperature Range	Working	-40		85	°C	
	Storage	-40		125	°C	
Current consumption						
Receive current			<28		mA	@Dual mode, VCC=3.3V, V_BCKP=3.3V
Sleep current			< 10		uA	VCC=0V, V_BCKP=3.3V
Radio frequency parameters						
Positioning accuracy			< 2		m	@Open land
Sensitivity	capture		-148		dBm	
	track		-162		dBm	
External antenna gain				30	dB	
Speed measurement accuracy			< 0.1		m/s	
Time to First fix (TTFF)	Cold start		≤ 32		s	
	Hot Start		≤ 1		s	
	Recapture		≤ 1		s	
Serial parameters						
Serial baud rate			9600	115200	bps	
Data update rate (Single mode)	BDS/GPS/GLONASS		1	5	Hz	Default 1 Hz
Data update rate (Dual mode)	BDS+GPS		1	5	Hz	
	BDS+GLONASS		1	5	Hz	
	GPS+GLONASS		1	5	Hz	
Data update rate (Tri-mode)	BDS+GPS+GLONASS		1	5	Hz	

7. Typical application circuit

- Active antenna is used:

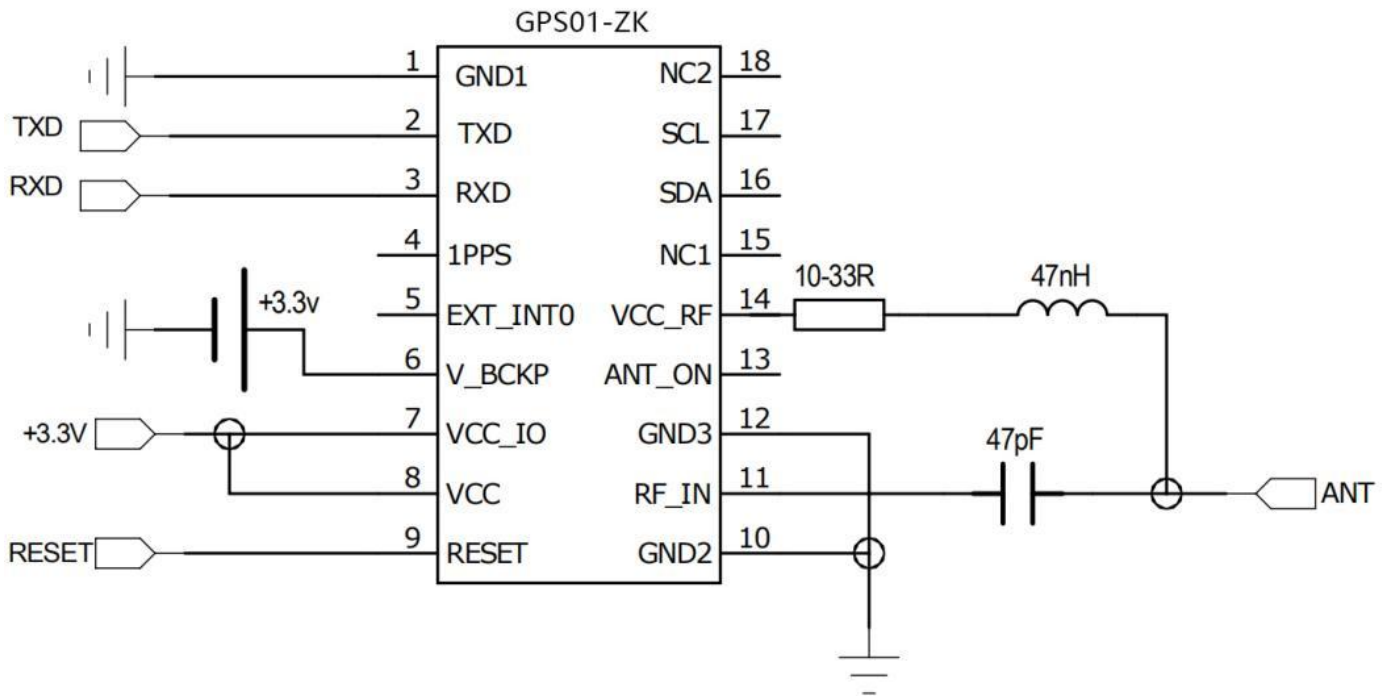

- Passive antenna is used:

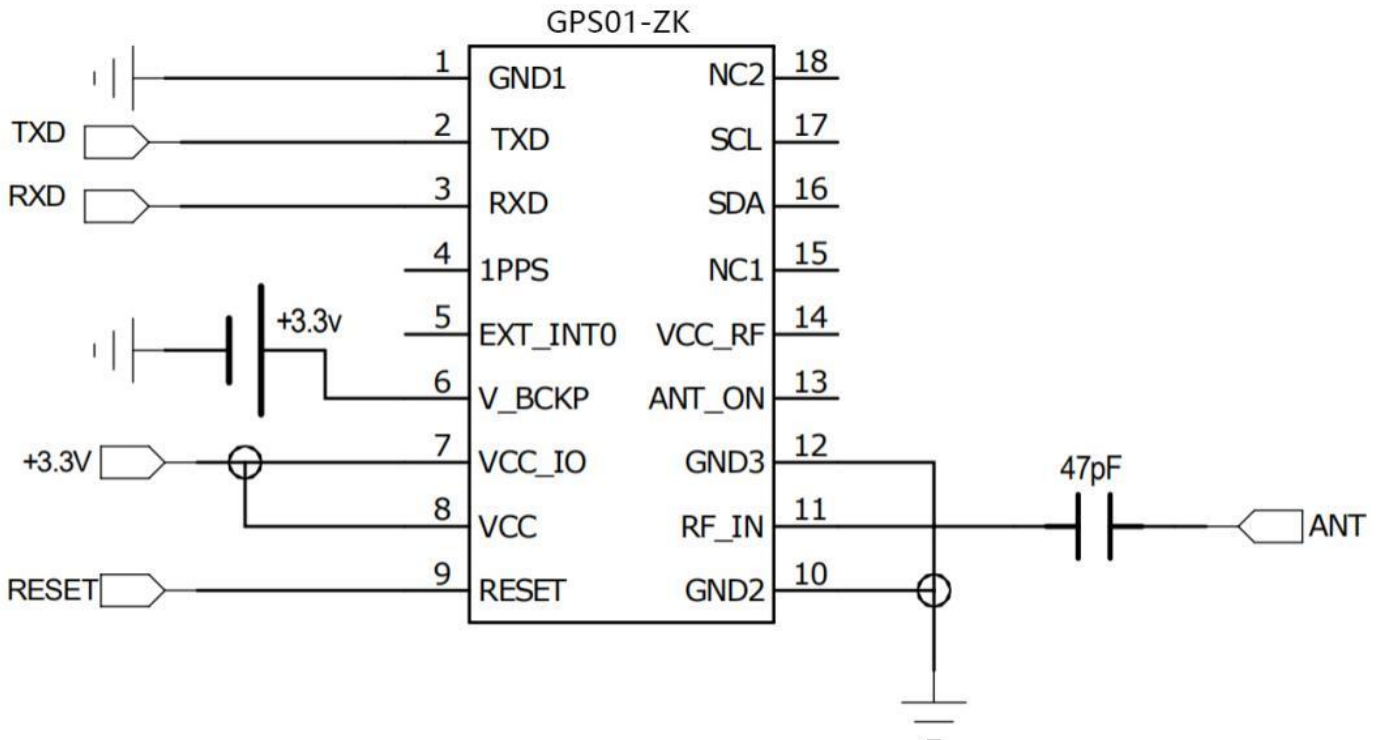

8. Pin definition

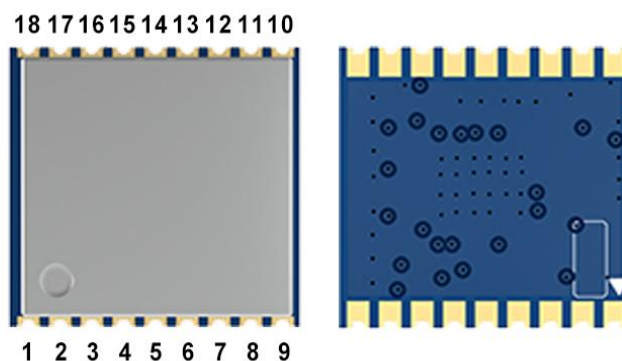

Pin number	Pin definition	I/O	Level standard	Description
1、 10、 12	GND	—		Power ground
2	TXD	O	0-3.5 V	Serial interface
3	RXD	I	0-3.5 V	Serial interface
4	1PPS	O	0-3.5 V	1 pulse output per second
5	EXT_INT0	I	0-3.5 V	Reserved
6	V_BCKP	I	2.5-3.5 V	Backup power input
7	VCC_IO	—	3.0-3.5 V	IO power input
8	VCC	—	3.0-3.5 V	Main power input
9	nRESET	I	0-3.5 V	External reset, active low. Cannot be connected to ground through capacitor.
C	RF_IN	I		Antenna input
13	ANT_ON	O	0-3.5 V	Reserved
14	VCC_RF	O	VCC	3.3V output, powered for the antenna or LNA, not exceed 20mA
15、 18	NC	—		
16	SDA	I/O	0-3.5 V	I2C interface
17	SCL	I	0-3.5 V	I2C interface

9. Recommended antenna index

Item		Active antenna	Passive antenna
Frequency range	BDS	1561.098 ± 2.046 MHz	1561.098 ± 2.046 MHz
	GPS	1575.42 ± 1.023 MHz	1575.42 ± 1.023 MHz
	GLONASS	1602.0 ± 4 MHz	1602.0 ± 4 MHz
Input impedance		50 Ω	50 Ω
Gain		< 30dB	-
In-band gain flatness		≤ 1.5dB	-
Noise Factor		≤ 1.5dB	-
Input standing wave		≤ 1.5	≤ 1.5
Output standing wave		≤ 2	≤ 2
Out-of-band rejection: 1568 ± 30MHz		≤30dB	-
Recommend working voltage		3.0V±0.3	-
Temperature range		-40~85°C	-40~85°C

10. Mechanical size (unit: mm)

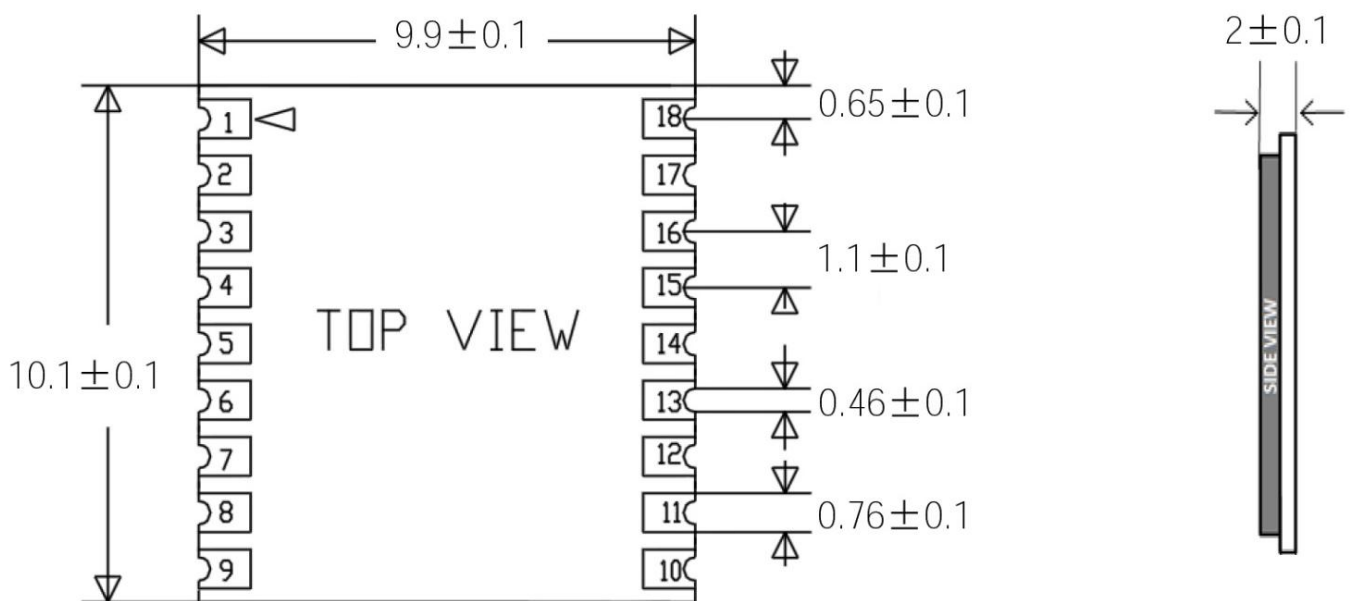

11. Recommended package

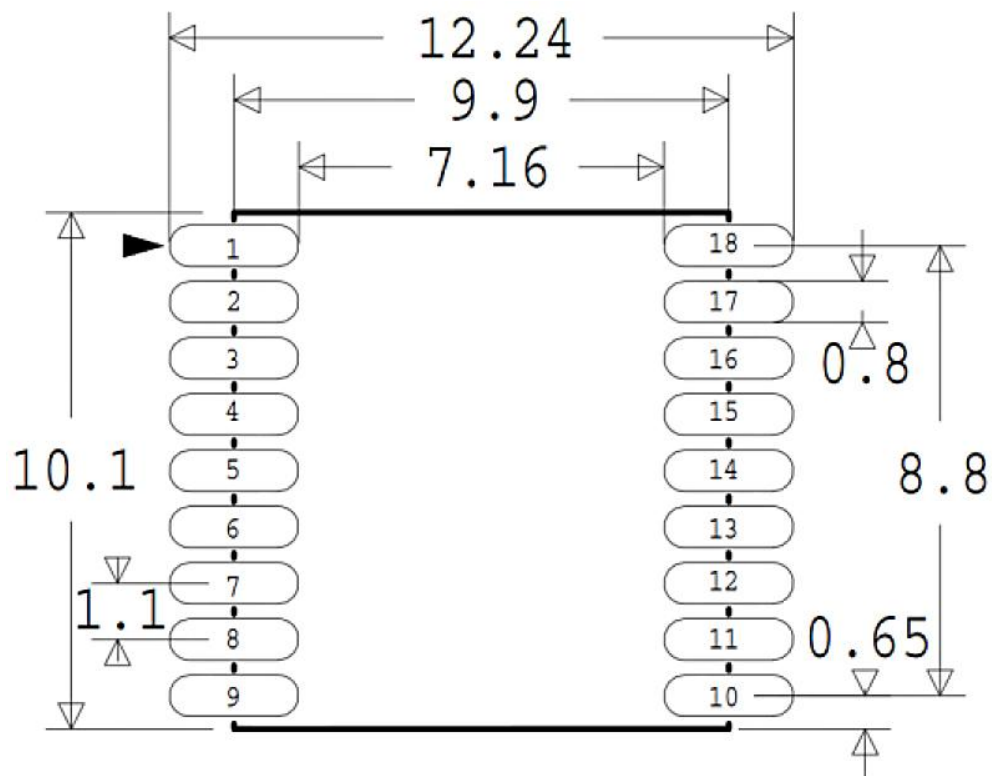

12. Attentions

- 1) The module contains electrostatic sensitive components. Please pay attention to electrostatic protection during soldering, installation and transportation. Please do not touch the RF_IN pin with bare hands, otherwise the module may be damaged.
- 2) Try to control the ripple of VCC power supply within 100mV.
- 3) Please ensure that the baud rate of the host computer and the module is same.
- 4) It is recommended to choose our active or passive antenna.
- 5) Please control the temperature when solder the module..

Appendix: SMD Reflow Chart

Below reflow profile is recommended for SMT technology::

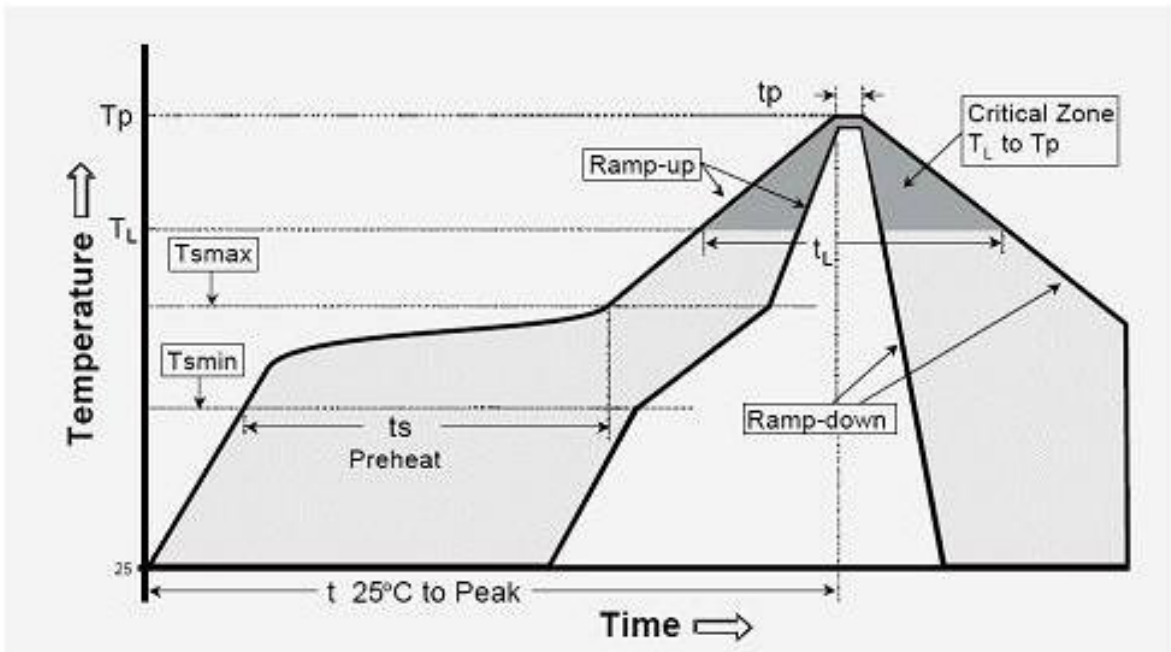

IPC/JEDEC J-STD-020B the condition for lead-free reflow soldering	big size components (thickness $\geq 2.5\text{mm}$)
The ramp-up rate (T _l to T _p)	3°C/s (max.)
preheat temperature	
- Temperature minimum (T _{smin})	150°C
- Temperature maximum (T _{smax})	200°C
- preheat time (t _s)	60~180s
Average ramp-up rate(T _{smax} to T _p)	3°C/s (Max.)
- Liquidous temperature(T _L)	217°C
- Time at liquidous(t _L)	60~150 second
peak temperature(T _p)	245+/-5°C