

BLE Module

MS50SFA

Datasheet

V 1.4.0

Applicable Product Model

MS50SFA-nRF52832

Version Note

Version	Details	Contributor(s)	Date	Notes
1.0.0	First edit	Coral	2020.5.21	
1.1.0	The firmware version has been updated to 2.5.3, and the serial port baud rate command takes effect from immediately taking effect to after resetting the command. Unified rendering	Coral	2021.2.8	
1.2.0	Modify default connection interval	Coral	2021.9.23	
1.3.0	Layout change	Coral	2022.4.20	
1.4.0	Style change	Michelle	2023.8.30	

MS50SFA-nRF52832

Bluetooth master-slave transparent transmission module that supports master-slave switching, serial command configuration, power supply voltage detection, and iBeacon broadcast mode

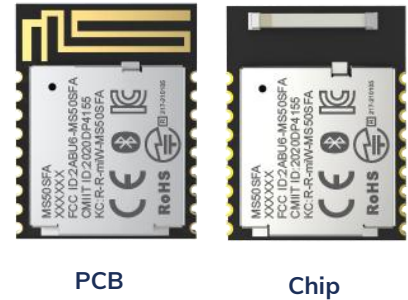

The MS50SFA is a master slave module that can be switched into master/slave mode through instructions. Master and never can work simultaneously and can only be connected one-on-one. The device defaults to host mode. In main mode, devices can be scanned and connected through instructions. Scanning can set broadcast name filtering and MAC address filtering to obtain relevant devices. The connection can only be initiated by specifying a MAC address. The device communicates with the MCU through the UART interface. In command mode, the UART can send commands to modify the scan interval, scan timeout, connection interval, broadcast interval, broadcast custom data, baud rate, etc. MCU sends switching commands to the slave through UART, which has broadcast and connection status and can be connected by the host, serving as a bridge between the host and MCU for transparent data transmission.

■ Features

- Supporting master-slave switching
- 1:1 connection
- The fastest transmission rate can reach 11kB/s
- Support serial port instruction configuration
- Supporting iBeacon broadcast mode

■ Application

Smart home, smart wearable devices, consumer electronics, smart healthcare, security equipment,

■ Certification information

BQB、CE、FCC、REACH、RoHS、KC、TELEC

■ Key parameter

Chip Model	Nordic nRF52832	Antenna	PCB/Chip
Module Size	15.8×12×2mm	GPIO	13
Flash	512kB	RAM	64KB
receiver sensitivity	-96dBm	Transmitting power	-40~ +4dBm
Emission Current	0dBm-5.3mA	Receiving Current	5.4mA
firmware	Master slave switch transparent firmware		

INDEX

1 Block Diagram	6
2 Electrical Specification	6
3 Current Consumption Characteristics	7
4 Pin Description	8
4.1 PCB antenna	8
4.2 Chip	8
5 Pin Definition	9
6 Module Operation Instruction	10
6.1 Tool	10
6.2 Demonstration of module application	10
6.2.1 Power supply	11
6.2.2 SLP(Sleep/Awake)	11
6.2.3 BTDATA(UART control)	11
6.2.4 UART interface:TX and RX	11
6.2.5 CON_IND	12
6.2.6 FIFO_FULL	12
6.2.7 Command instruction	12
6.3 Example of operation	18
6.3.1 Factory Default Parameters	18
6.3.2 Example of Modifying Parameters	19
6.3.3 Scanning devices and connections	20

6.3.4 mainframe transmission.....	21
6.3.5 slave radio.....	22
6.3.6 slave transponder.....	24
7 Mechanical Drawing.....	25
7.1 PCB antenna.....	25
7.2 Chip.....	25
8 Electrical Schematic.....	26
9 PCB Layout.....	27
10 Reflow and Soldering.....	29
11 Package Information.....	30
Quality.....	31
Contact Us.....	31
Copyright Statement.....	32

1 Block Diagram

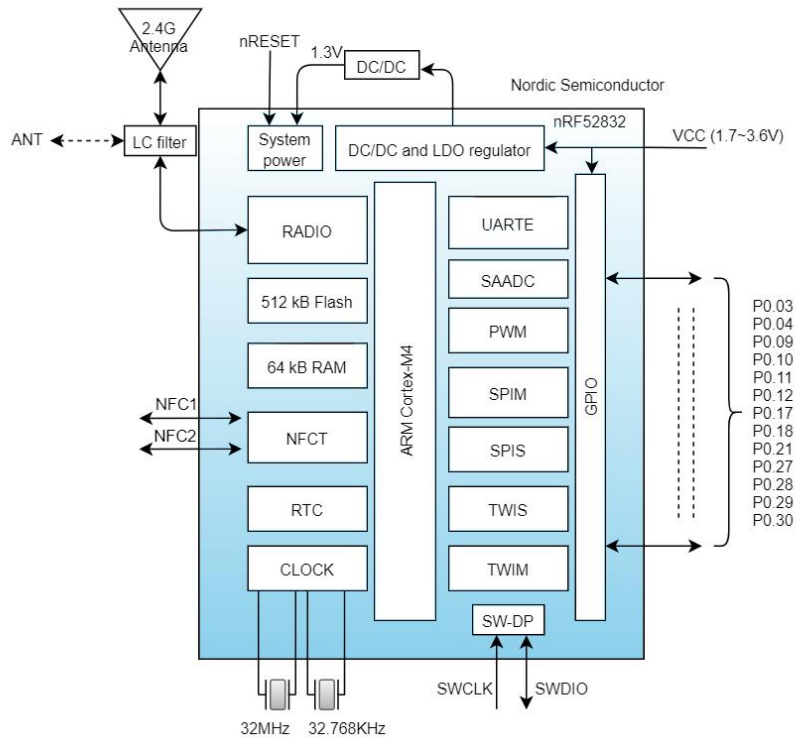

2 Electrical Specification

Parameter	Values	Notes
Working Voltage	1.7V-3.6V	To ensure RF work, supply voltage suggest not lower than 2.3V
Working Temperature	-40°C~+85°C	Storage temperature is -40°C~+125°C
Transmission Power	-40 ~ +4dBm	Configurable
Receiving Current	5.4mA	RF reception current in 1Mbps mode
Emission Current	5.3mA	RF emission current in 0dB mode
Module Dimension	15.8*12*2mm	
Quantity of IO Port	13	

3 Current Consumption Characteristics

The following power consumption test is conducted at room temperature with a power supply voltage of 3.3V. The power consumption of the host mode and the slave mode is inconsistent.

When in mode, the power consumption is as follows: (broadcast interval is 1s, maximum and minimum connection interval is 20-40ms).

Status	Consumption	Peak(mA)	Avg(mA)
	Average current in sleep state (SLP pulled high, BTDATA pulled low)	0.079	0.0002
	Broadcast average current (SLP pin is connected to GND, BTDATA is pulled high)	5.997	0.0152
	Connection state average current (SLP pin is connected to GND, BTDATA is pulled high)	6.179	0.118
	Transparent transmission average current (SLP, BTDATA pins are connected to GND, connected to mobile phones)	6.634	0.4954

When in host mode, the power consumption is as follows: (The maximum and minimum connection interval is 20-40ms)

Status	Consumption	Peak(mA)	Avg(mA)
	Average current in sleep state (SLP pulled high, BTDATA pulled low)	0.6085	0.0013
	Transparent transmission average current (SLP, BTDATA pins are connected to GND)	6.6506	1.847

4 Pin Description

4.1 PCB antenna

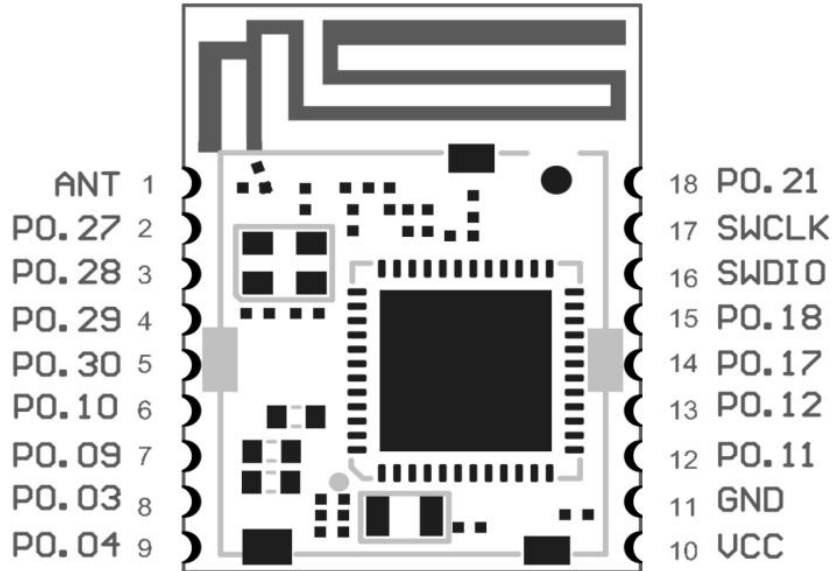

4.2 Chip

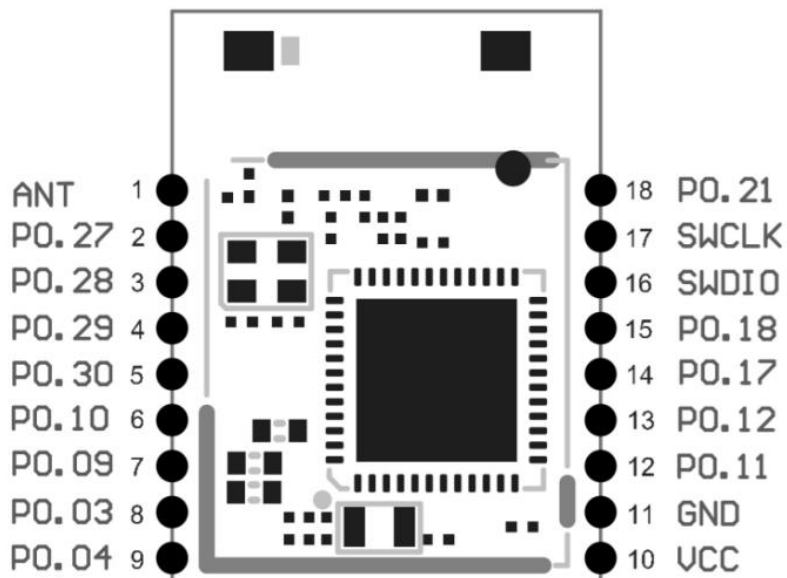

5 Pin Definition

Pin Number	Symbol	Type	Definition	Note
1	ANT		External antenna pins	Using the module's built-in antenna, this pin is directly suspended in the air.If the module's built-in antenna is not used, the antenna can be externally connected through this pin. When connecting the antenna, the resistor connected to the antenna needs to be horizontally welded to this pin
2~7	P0.27 to P0.09		GPIO	Not used in UART, floating
8	P0.03	BTX	UART TX	TX of Bluetooth Module
9	P0.04	BRX	UART RX	RX of Bluetooth Module
10	VCC	VCC	Power Supply	
11	GND	GND	Ground	
12	P0.11	CON_IND	Connection indication	Sleep state: low level Broadcast status: Low level Connection status: High level
13	P0.12	FIFO_FULL	Transmission space full	Determine if the transmission space is available when it is full 0: Bluetooth module has available space for transmission 1: Host stops transmitting and waits for free space to be released
14	P0.17	SLP	Sleep/Awake	Low level to wake-up,high level to sleep, no floating
15	P0.18	BTDATA	Serial port control	Serial port on / off to control pin, no floating 0: serial port open, can send and receive serial port data 1: Serial port off
16	SWCLK		Burn clock pin	Used for burning firmware
17	SWDIO		Burn data pin	Used for burning firmware
18	P0.21		GPIO	Not used in UART, floating

6 Module Operation Instruction

6.1 Tool

PC serial port assistant: Baidu "Friendly Serial Port Assistant" can be downloaded. The PC serial port assistant is used to debug the UART interface of the module.

6.2 Demonstration of module application

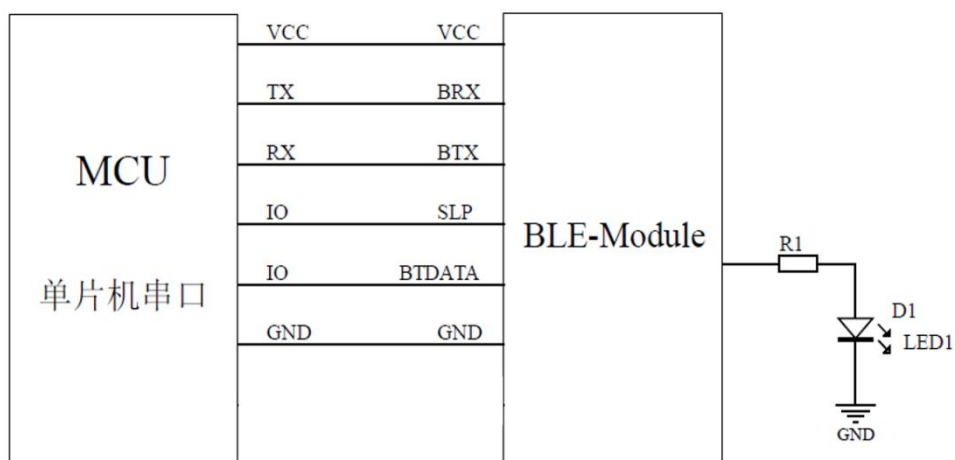

6.2.1 Power supply

The SoC working voltage is 1.7V-3.6V, to ensure a stable function, supply voltage should be 3.0V-3.6V.

6.2.2 SLP(Sleep/Awake)

When pull SLP low, the module in broadcast mode. BLE device can be found by smartphone APP, Device name: Minew_Vxxxxx(default) name, module can be connected with smartphone and enters connection mode. When pull SLP high, device will enter sleep mode.

Note: This pin cannot be left floating to avoid unpredictable errors.

6.2.3 BTDATA(UART control)

The BTDATA pin is only valid when SLP is low. SLP is low, BTDATA is low, and when the module is in a broadcast state, all UART data will be considered as instructions. When the module is connected, all data is considered transparent.

Note: This pin cannot be left floating to avoid unpredictable errors.

6.2.4 UART interface:TX and RX

When both SLP and BTDATA in low level,UART port will be activated,the module TX and RX should be connected to MCU RX and TX,then start to communicate through UART.

In the test,module TX and RX can be connected with an UART to USB module's RX and TX pin, then send command through Serial Port Utility App from PC.

Note : The TX and RX of 2 modules can be connected reversed, each module connect with a smart phone, then transfer data over BLE between each smart phone.

6.2.5 CON_IND

CON_IND is used to indicate module status, high level in connection mode, low level in sleep or broadcast mode to wake up MCU and save power.

6.2.6 FIFO_FULL

FIFO_FULL is used to indicate whether the cache is full or not. When sending large amount of data from MCU to module, this pin can be added to judge. If it is high, then the FIFO is full, and you can not continue to send UART data at this time to avoid packet loss.

6.2.7 Command instruction

After connecting VCC and GND, the SLP and BTDATA pins are directly grounded. At this time, the module is in an unconnected state, that is, the module is in command mode and the serial port is turned on. Instructions can be sent to set and query parameters.

For all device instructions, the returning result is the same:

54544D3A4F4B0D0A00(TTM:OK\r\n\0) is returned after command sent successfully

54544D3A4552500D0A00 (TTM:ERP\r\n\0) is returned after command failed

After sending the correct setting command, the parameters take effect immediately (the baud rate only takes effect after sending the reset command), and the power outage will not be saved at this time. Only after sending the reset command will it be saved to flash.

Below is the list of setup instructions:

Note: The first line in the command list should be sent by Hex format, the second line should be sent by ASCII format. When checking the parameter, the returned result are all hexadecimal numbers, so you need to use hexadecimal numbers to parse the command.

After SLP and BTDATA are grounded, the device is in the host state, and the host related parameters include scan timeout, scan interval, and connection interval. The command to set the connection interval is effective for both the host mode and the slave mode. Scan timeout and scan interval are only valid under the host module:

Function	Command (hex/ASCII)	Description
Setting the scan timeout	54544D3A5343542D<Para>	Length: 1 Byte, Values: 0-29, Para*5S, 0 means scanning all the time and output scanning result in real time.
	TTM:SCT-<Para>	
Query Scan Timeout	54544D3A5343543F	Return TTM:SCT-<Para>\r\n\0, Para: Hexadecimal
	TTM:SCT?	
Setting the scanning interval	54544D3A5349572D<Para>	Length: 1 Byte, Value: 0-100, Para*10S
	TTM:SIW-<Para>	
Query Scan Interval	54544D3A5349573F	Return TTM:SIW-<Para>\r\n\0, Para: Hexadecimal
	TTM:SIW?	
Setting up RSSI filtering	54544D3A5253492D<Para>	Value: -120 ~ -30dBm, if less than -100dbm, then disable RSSI filtering.
	TTM:RSI-<Para>	
Query RSSI Filtering	54544D3A5253493F	Return TTM:RSI-<Para>\r\n\0, Para: Hexadecimal
	TTM:RSI?	
Setting up broadcast name filtering	54544D3A404E462D<Para>	Length: 16 Byte, Value: ASCII code
	TTM:AVF-<Para>	
Query Broadcast Name Filtering	54544D3A404E463F	Return TTM:ANF-<Para>\r\n\0, Para: Hexadecimal
	TTM:ANF?	
Cancel broadcast name filtering	54544D3A404E462D	Cancel broadcast name filtering
	TTM:ANF-	
Setting up MAC address filtering	54544D3A4D41462D<Para>	Length: 6 Byte, value: hexadecimal number
	TTM:MAF-<Para>	
Query MAC Address Filtering	54544D3A4D41463F	Return TTM:MAF-<Para>\r\n\0, Para: Hexadecimal
	TTM:MAF?	
Cancel MAC address filtering	54544D3A4D41462D	Cancel MAC address filtering

Note: RSSI, broadcast name and MAC address filtering are added to make it easier to locate the device; only one of MAC address filtering and broadcast name filtering can be effective at the same time; when MAC address filtering is turned on, broadcast name filtering will be turned off automatically; when broadcast name filtering is turned on, MAC address filtering will be turned off automatically

As a host, you need to send relevant commands to let the device enter the Bluetooth state, such as scanning and initiating a connection to a certain device, and after connecting, when transmitting data, you will judge all the data whether it is a disconnect command.

Function	Command (hex/ASCII)	Description
Turn on scanning	54544d3a5343414e TTM:SCAN	Command correctly return: TTM:SCANNING\r\n\r\n0, error return TTM:ERP\r\n\r\n0, after scanning to the device serial port output 10 RSSI value of the strongest device, scanning timeout is 0 or MAC address filtering scanning output results format 0xAA + MAC + RSSI + adv_data + 0x0D0A, the rest of the output for MAC + broadcast name
stop scanning (computing)	54544d3a5343414e2d53544f50 TTM:SCAN-STOP	The instruction returns correctly: TTM:SCAN-STOP\r\n\r\n0, incorrectly returns TTM:ERP\r\n\r\n0
Connect to the specified MAC	54544D3A434F4E4E2D <MAC> TTM:CONN-<MAC>	Command return: TTM:CONNING\r\n\r\n0, indicating connection in progress TTM:CONN-TOUT\r\n\r\n0, connection timeout TTM:NO-DEVICE\r\n\r\n0, device not found TTM:CONN-MAC-XXXXXXXXXXXXXXXX\r\n\r\n0, connected TTM:MAC-DCON-XXXXXXXXXXXXXXXX\r\n\r\n0, Disconnect TTM:ERP\r\n\r\n0, Command Error
Disconnect all connections	54544D3A444953432D414C4C TTM:DISC-ALL	Correctly return TTM:DISC-XXXXXXXXXXXX\r\n\r\n0, incorrectly return TTM:ERP\r\n\r\n0

Note: The above commands are only valid in host mode, sending these commands when the device role is not host will return TTM:ERP\r\n\r\n0.

Except for the above four commands, all other device commands, whether in master or slave mode, will return TTM:OK\r\n\r\n0 as long as they fulfill their parameter range requirements, and the parameters will take effect when the corresponding roles are in

A master device can initiate a connection to a slave device with a specified MAC and enter connection mode. When the MAC address of the desired connected device is known, the connection command can be sent directly without scanning.

When the device is switched from master mode to slave mode, it is necessary to first ensure that the device is in the unconnected state, call the set role command, and then call the reset command, which can successfully switch to the slave role, and vice versa.

Function	Command (hex/ASCII)	Description
Setting up the role	54544D3A524F4C2D <Para>	Length: 1 Byte, Values: 0-1, 0 for slave mode, 1 for master mode
	TTM:ROL-<Para>	
Query Role	54544d3a524f4c3f	Return to TTM:ROL-<Para>\r\n\0, Para: Hexadecimal
	TTM:ROL?	

When in slave mode, you can set and query many parameters of the broadcast process and connection process as follows:

Function	Command (hex/ASCII)	Description
Setting the broadcast name	54544D3A52454E2D <Para>	Length: 1-16 Byte, Value: ASCII
	TTM:REN-<Para>	
Query broadcast name	54544d3a52454e3f	Return TTM:REN-<Para>\r\n\0, Para is ASCII
	TTM:REN?	
Setting the broadcast interval	54544D3A4144502D <Para>	Length: 1 Byte, value: 1-20, corresponding to broadcast interval 1*100ms.
	TTM:ADP-<Para>	
Query broadcast interval	54544D3A4144503F	Return TTM:ADP-<Para>\r\n\0, Para: Hexadecimal
	TTM:ADP?	
Setting the transmit power	54544D3A54504C2D <Para>	Length: 1 Byte, Values: 0-8, corresponding to -40, -20, -16, -12, -8, -4, 0, +4, +8 (unit: dB)
	TTM:TPL-<Para>	
Query Transmit Power	54544D3A54504C3F	Return TTM:TPL-<Para>\r\n\0, Para: Hexadecimal
	TTM:TPL?	
Setting the broadcast data	54544D3A4144442D <Para>	Length: 1-16 Byte, value: any hexadecimal number
	TTM:ADD-<Para>	
Query Broadcast Data	54544D3A4144443F	Return TTM:ADD-<Para>\r\n\0, Para: Hexadecimal
	TTM:ADD?	
Setting the factory ID	54544D3A5049442D <Para>	Length: 2 Byte, value: any hexadecimal number
	TTM:PID-<Para>	

Query Factory ID	54544D3A5049443F TTM:PID?	Return TTM:PID-<Para>\r\n\0, Para: Hexadecimal
Setting the Service UUID	54544D3A5549442D <Para> TTM:UID-<Para>	Length: 6Byte, (2 Byte service uuid+2 Byte rx UUID+2 Byte tx UUID) Values: Any hexadecimal number, service, rx, tx UUID can't be the same.
Query Service UUID	54544D3A5549443F TTM:UID?	Return TTM:UID-<Para>\r\n\0, Para: Hexadecimal
Setting the broadcast mode	54544D3A4D4F442D <Para> TTM:MOD-<Para>	Set device broadcast packet format: 0: pass-through broadcast packet 1: iBeacon broadcast packet, you can see the specific broadcast packet format instructions
Query broadcast mode	54544d3a4d4f443f TTM:MOD?	Return TTM:MOD-<Para>\r\n\0, Para: Hexadecimal
Setting the UUID	54544D3A4149442D <Para> TTM:AID-<Para>	Length: 16 bytes, value: any hexadecimal number
Query UUID	54544D3A4149443F TTM:AID?	Return TTM:AID-<Para>\r\n\0, Para: Hexadecimal
Set Major	54544D3A4D414A2D<Para> TTM:MAJ-<Para>	Length: 2 bytes, value: any hexadecimal number
Query Major	54544D3A4D414A3F TTM:MAJ?	Return to TTM:MAJ-<Para>\r\n\0, Para: Hexadecimal
Set Minor	54544D3A4D494E2D <Para> TTM:MIN-<Para>	Length: 2 bytes, value: any hexadecimal number
Query Minor	54544d3a4d494e3f TTM:MIN?	Return TTM:MIN-<Para>\r\n\0, Para: Hexadecimal
Setting the connection mode	54544D3A5057452D <Para> TTM:PWE-<Para>	Whether the device requires a password to connect, 0: no password required to connect 1: Connection password required
Query Connection Mode	54544D3A5057453F TTM:PWE?	Return TTM:PWE-<Para>\r\n\0, Para: Hexadecimal
Setting the connection password	54544D3A5057442D <Para> TTM:PWD-<Para>	Length: 1-8 bytes, value: ASCII, the correct password must be entered within 5s on the connection, otherwise the connection will be disconnected
Query connection password	54544D3A5057443F TTM:PWD?	Return to TTM:PWD-<Para>\r\n\0, Para:ASCII

Whether in host mode or slave mode, all setting instructions require reset instructions to take effect, while query instructions will return relevant parameters, and instruction errors will return TTM: ERP r n 0. For the entire device, the baud rate and connection interval instructions will take effect regardless of whether it is in master mode or slave mode.

Function	Command (hex/ASCII)	Description
Setting the baud rate	54544D3A4250532D <Para>	Length: 1 Byte, Values: 0-4, corresponding to 9600/ 19200/38400/57600/115200 (unit: bps) respectively.
	TTM:BPS-<Para>	
Query Baud Rate	54544D3A4250533F	Return TTM:BPS-<Para>\r\n\0, Para: Hexadecimal
	TTM:BPS?	
Setting the connection interval	54544D3A4349542D <Para>	Length: 1 Byte, value: 1-100, corresponding to the minimum connection interval 1*10ms, maximum connection interval = minimum connection interval + 10ms.
	TTM:CIT-<Para>	
Query Connection Interval	54544D3A4349543F	Return to TTM:CIT-<Para>\r\n\0, Para: Hexadecimal
	TTM:CIT?	
Retrieve MAC address	54544d3a4d4143(2d)3f	Return TTM:MAC-<Para>\r\n\0, Para: Hexadecimal
	TTM:MAC-? or TTM:MAC?	
Read version information	54544d3a564552(2d)3f	Return to TTM:VER-<Para>\r\n\0, Para:ASCII
	TTM:VER-? or TTM:VER?	
Restore factory equipment	54544d3a5253542d464143	Consistent with the return of the setup command
	TTM:RST-FAC	
reset (a dislocated joint, an electronic device etc)	54544d3a5253542d535953 TTM:RST-SYS	Success will return TTM:OK\r\n\0

6.3 Example of operation

6.3.1 Factory Default Parameters

Broadcast Name: Minew_Vxxxxx

Serial port baud rate: 9600bps,8N1

Transmit power: 0dBm

Minimum and maximum connection interval: 20ms - 40ms

Device Role: Host

Default parameters related to host mode:

Scanning timeout: 10s

Scanning interval: 100ms

Default parameters related to slave mode:

Broadcast interval: 1s

Broadcast mode: transparent broadcast package

Custom data: Minew Tech

Connection password enable: not enabled

Connection password: minew123

Major: 0x1234

minor: 0x1235

UUID: 74278BDA-B644-4520-8F0C-720EAF059935

DC_RC: DCDC on, internal 32K

6.3.2 Example of Modifying Parameters

Connect all the pins according to the wiring, ground SLP and BTDATA, the device enters the unconnected state, at this time you can set the parameters, whether it is the host mode or the slave mode, all the parameters can be set, the parameters take effect immediately. Parameters after taking effect can only be reflected under the corresponding role. For example, if the broadcast name of the device is changed in the host mode, the parameters will take effect, but only when the device is switched to the slave mode will you see that the broadcast name has been changed. After sending the reset command, all the parameters are powered down and saved.

Note: When you need to modify multiple parameters, you can send all the setting commands first and then send the reset command.

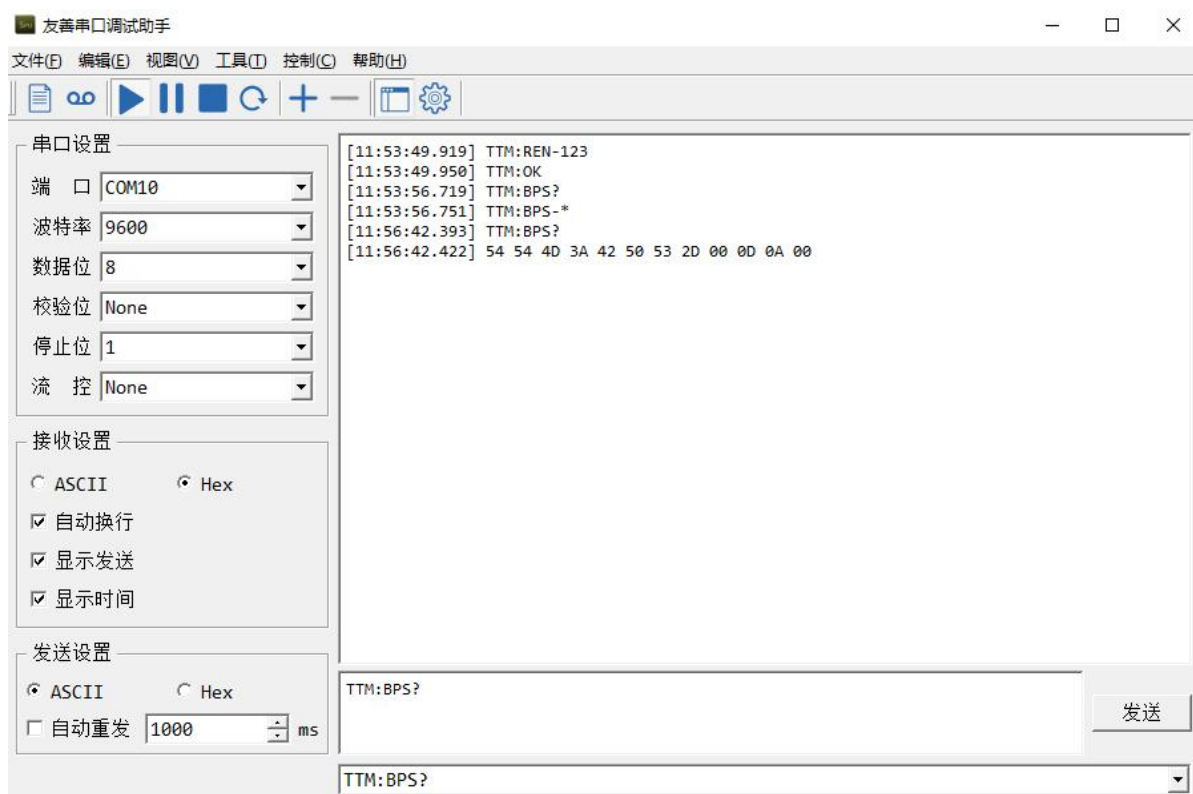

When querying the device parameters, because the parameters are hexadecimal numbers, when selecting the ASCII display, the parameter position may be garbled, at this time, you need to set to HEX display, the parameters correspond to the position after 2D, see the above figure, query the baud rate, you need to use the HEX display to view the specific parameters.

6.3.3 Scanning devices and connections

Send the 54544D3A5343414E (TTM:SCAN) command to scan for a device and obtain its MAC address. The scanned device returns MAC + broadcast name information. Send the 54544D3A434F4E4E2D201907230857 command and the module will connect the device with MAC address 20:19:07:23:08:57. The device connected will return TTM:CONN-MAC-XXXXXXXXXXXX\r\n0. Since MAC is a hexadecimal number, the entire command is sent as a hexadecimal number. Once connected you can perform data passthrough.

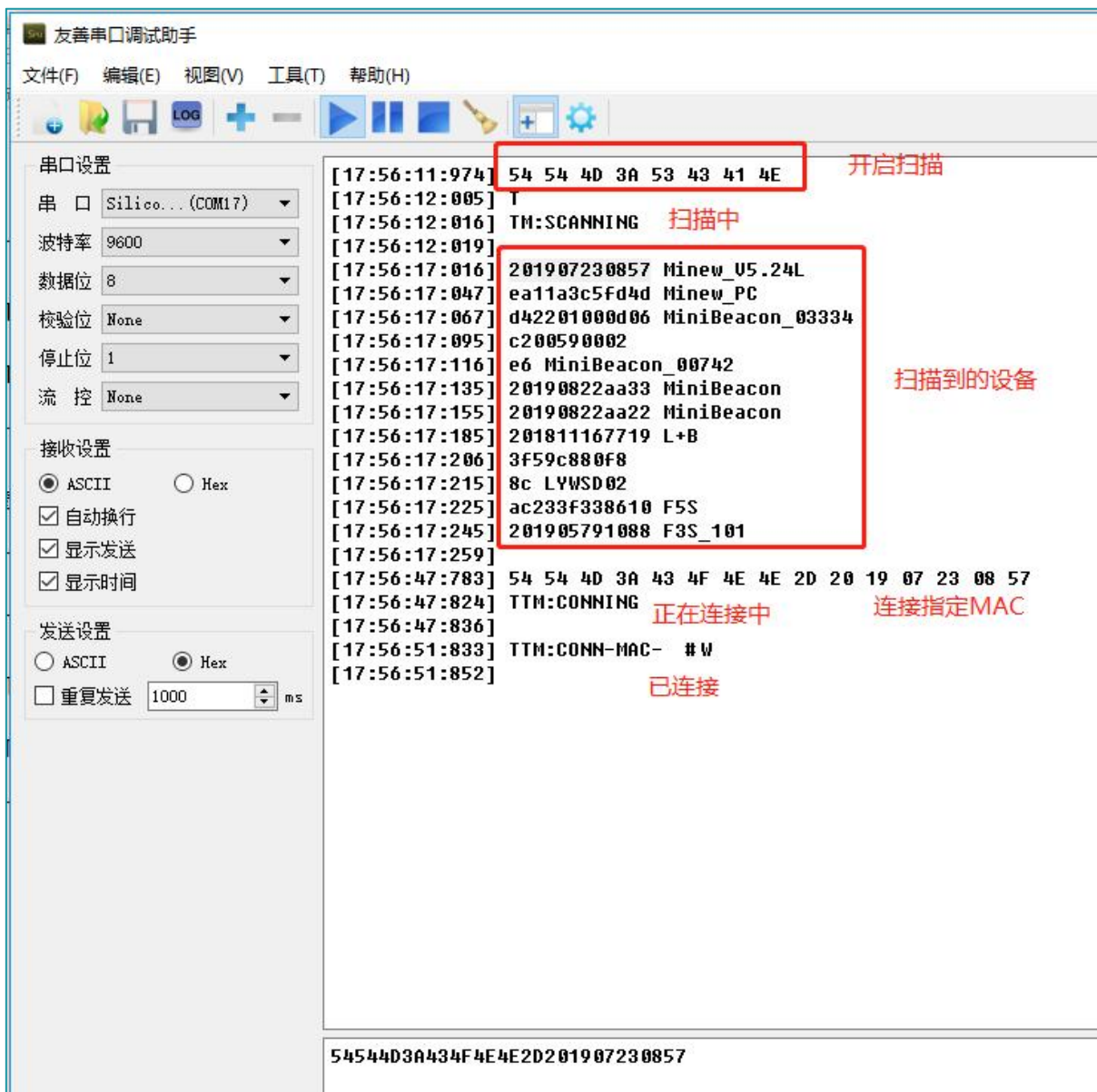

6.3.4 mainframe transmission

Data passthrough is possible after the connected command is returned in step 6.3 The prerequisite for correct communication between the module and the slave device is that the slave device must have the same services, features, and their UUIDs and attributes as the module.

Relevant information is provided below:

Eigenvalue UUID	executable operation	Packet length	note
FFF1	notify	244	Module data reception, the data sent from the device to the module shall not exceed 244 Byte per packet.
FFF2	write	244	Module data sending, the module has to do automatic packetization, data more than 244 Byte will be automatically divided into 244 packets sent to the slave device.

As an example, the master module connects to the passthrough slave module, and then sends the data after connecting.

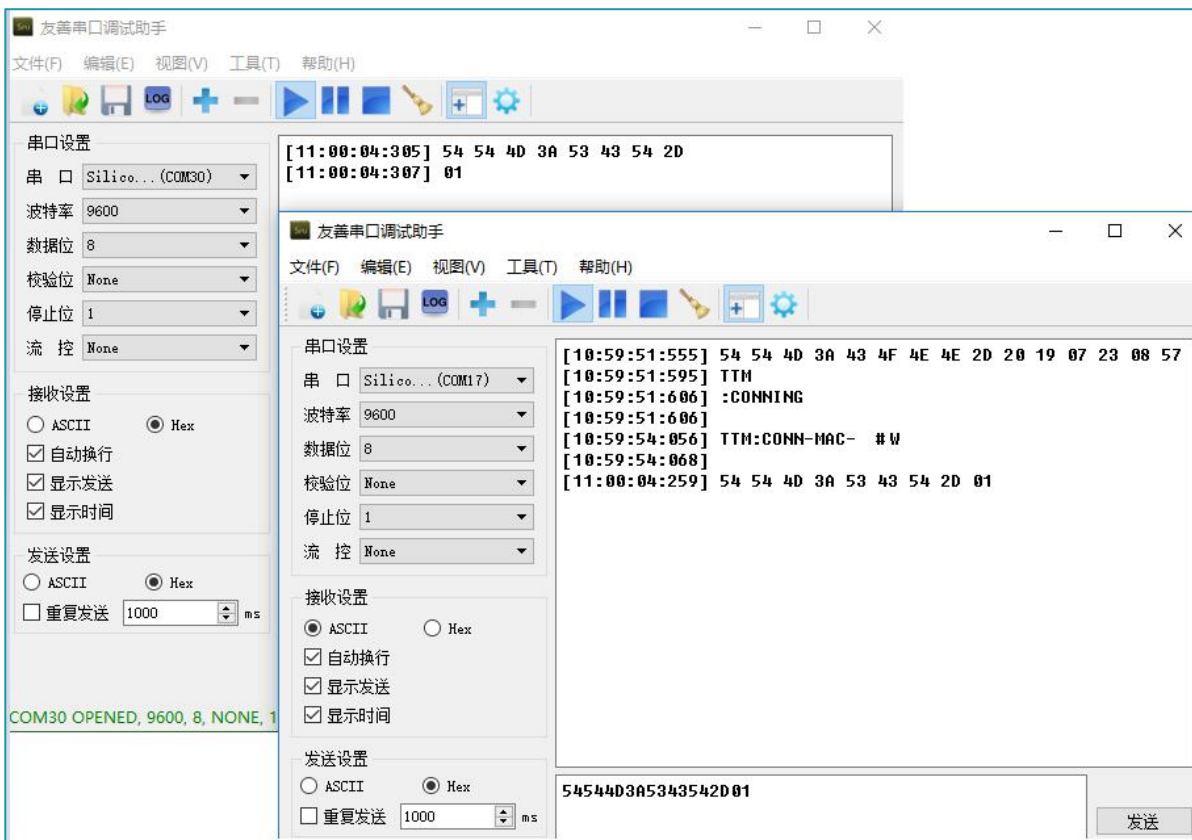

6.3.5 slave radio

After setting the device role to slave mode with the command TTM:ROL-0, data can be transmitted to and from the cell phone. With the SLP pin low, the device is in broadcast state. Use nrf connect to scan the device, click Raw after scanning to the device, Raw data is the unparsed data of the scanned device. After parsing the data according to BLE data type, see Detail section, BLE broadcast data has a certain format: length + type + content.

The content is changeable, the type is fixed and the length is determined by the content. There are two broadcast formats for the device, the pass-through broadcast packet and the iBeacon broadcast packet. Both formats contain four types: flag(0x01), broadcast name(0x09), service data(0x16), and manufacturer data(0xFF).

The following figure shows the transmitting broadcast packet: flag, broadcast name, service data is put in the broadcast packet, manufacturer data is put in the reply packet. The service data content is: service data UUID(E1FF) + MAC address. manufacturer data content consists of company id(3906) + battery level information(1 byte) + custom data.

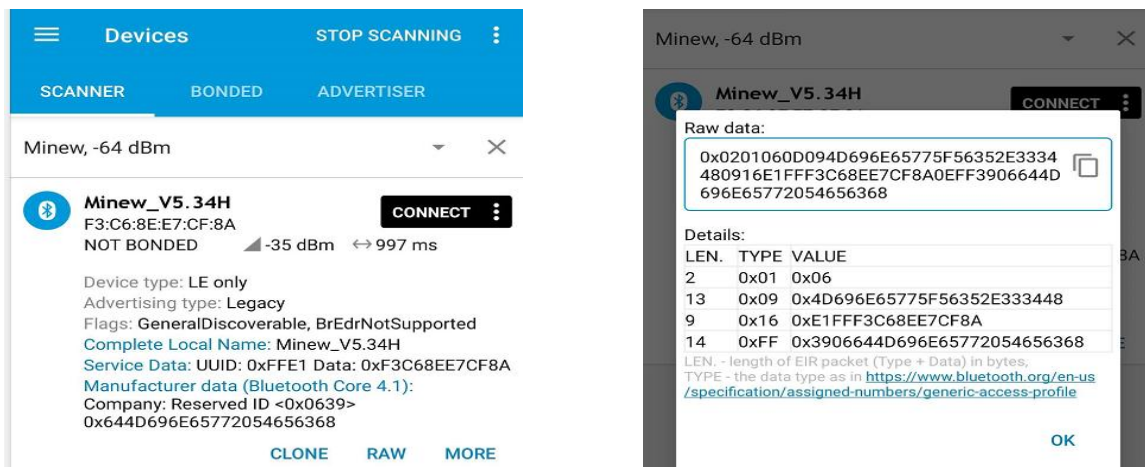

Note: The IOS side can not get the content of the MAC address field, so the MAC address is put back into the broadcast packet to ensure that the IOS side can get the device MAC address. In addition, the WeChat applet can't get the reply packet, so the MAC is put into the service data of the broadcast packet to ensure that the IOS side can also get the device MAC address using the WeChat applet connection.

The following figure shows the iBeacon broadcast packet: flag, manufacturer data is put in the broadcast packet, service data and broadcast name are put in the reply packet. The broadcast packet must follow this fixed format to fulfill the iBeacon protocol definition. In manufacturer data data, 4C 00 is Apple's company id, 02 15 is iBeacon's fixed format, Proximity uuid(16 bytes)+Major(2 bytes)+Minor(2 bytes)+Measured power(1 byte). In iBeacon broadcast mode, manufacturer data can only change the value of Proximity uuid, Major, Minor.

service data= service data UUID(FFE1) + battery level information + MAC address.

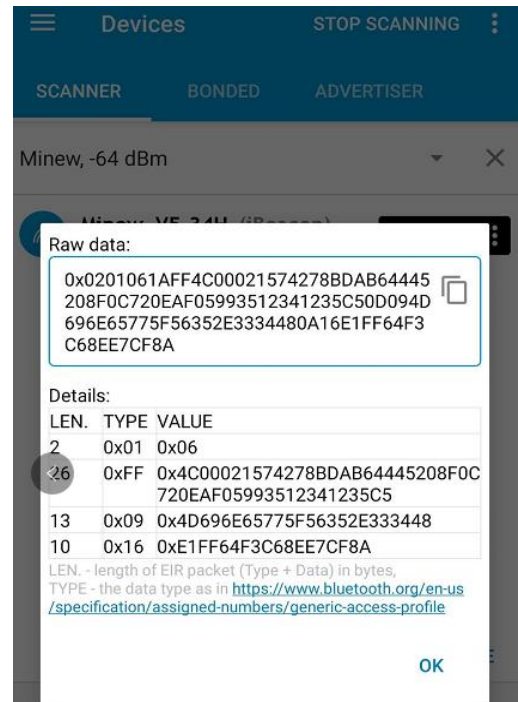
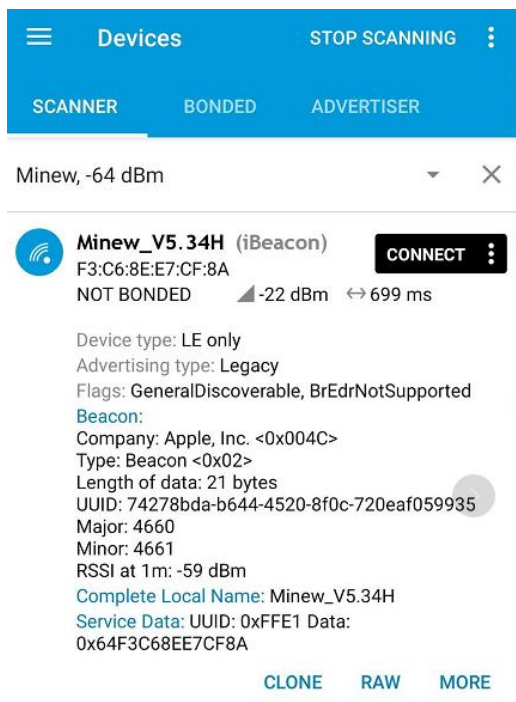

6.3.6 slave transponder

Based on 7.2, connect to the device using the mobile app and keep the BTDATA pin low to perform data passthrough. when BTDATA is not low, it does not affect the broadcasting and connecting of the device, just that passthrough is not possible. Using nRF connect, you can see the specific service, characteristic and corresponding properties.

The UUID consists of the alias UUID (2 byte, 3.4 byte on the left in the figure) + the base UUID (the remaining 14 byte).

The base UUID used for services, features in the passthrough program is standard and is illustrated below with the alias UUID.

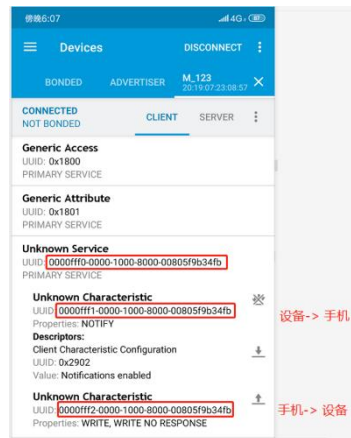

FFF0 is the service UUID, FFF1 is the cell phone receives data and the module sends data; FFF2 is the cell phone sends data and the module receives data.

Eigenvalue UUID	executable operation	Maximum Packet Length	note
FFF1	notify	244	The serial port sends data to the module, which is forwarded to the phone. The cell phone enables notify before it can get the data. The maximum number of bytes the module can send in a packet is 244 byte. Note: This process is automatically subcontracted by the firmware, and it is not necessary to subcontract according to the length of a packet. However, the maximum length of each packet cannot exceed 10k, and the transmission interval needs to consider the rate, otherwise it may cause packet loss, disconnection, and other situations.
FFF2	write	244	The phone sends data to the module and forwards it to the serial port. When using the API interface function to write data, the maximum length of data written at one time is 244 bytes

7 Mechanical Drawing

7.1 PCB antenna

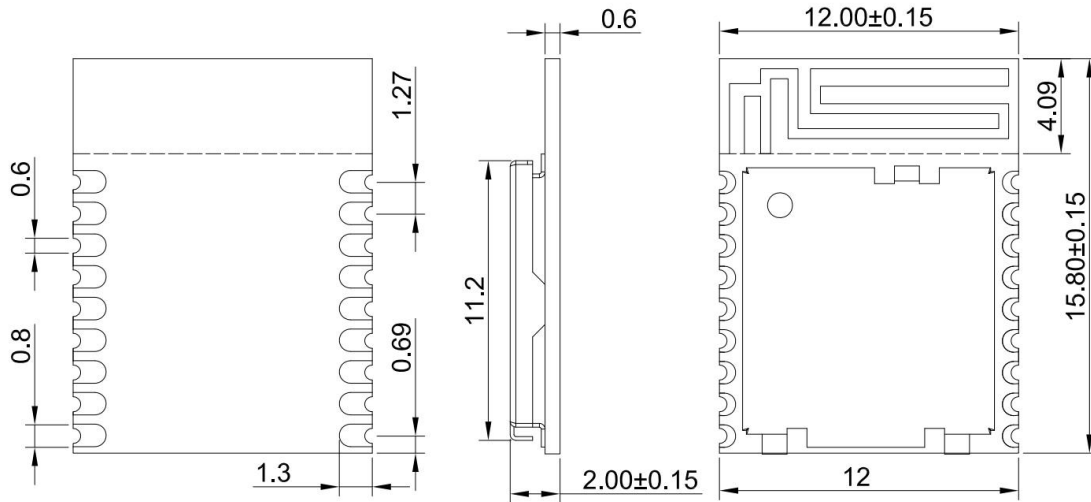

(Default unit: mm Default tolerance: ±0.1)

7.2 Chip

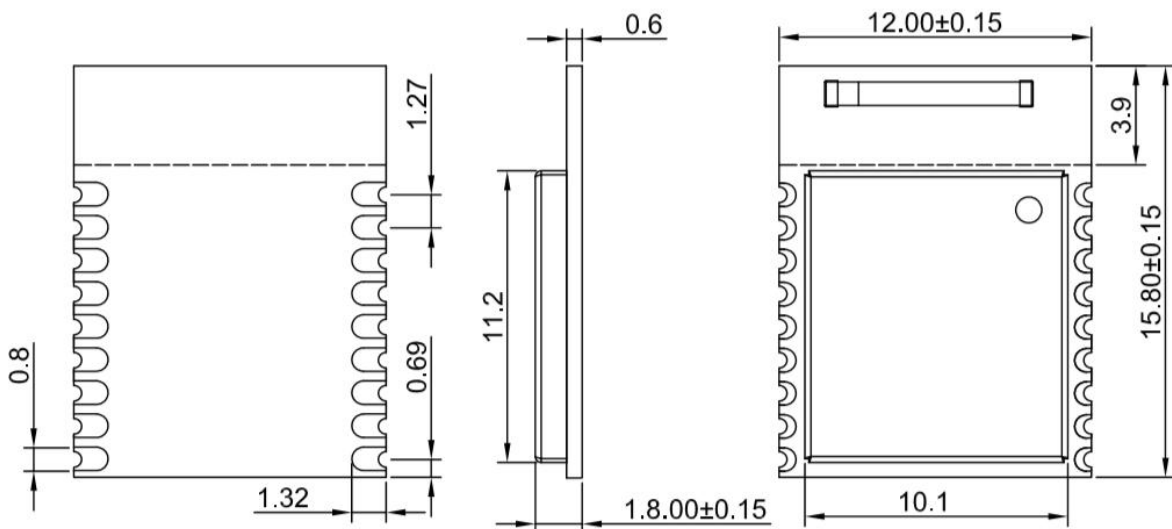

(Default unit: mm Default tolerance: ±0.1)

Note: Recommended pad size 1.8*0.8mm, pad extends outward 0.5mm

8 Electrical Schematic

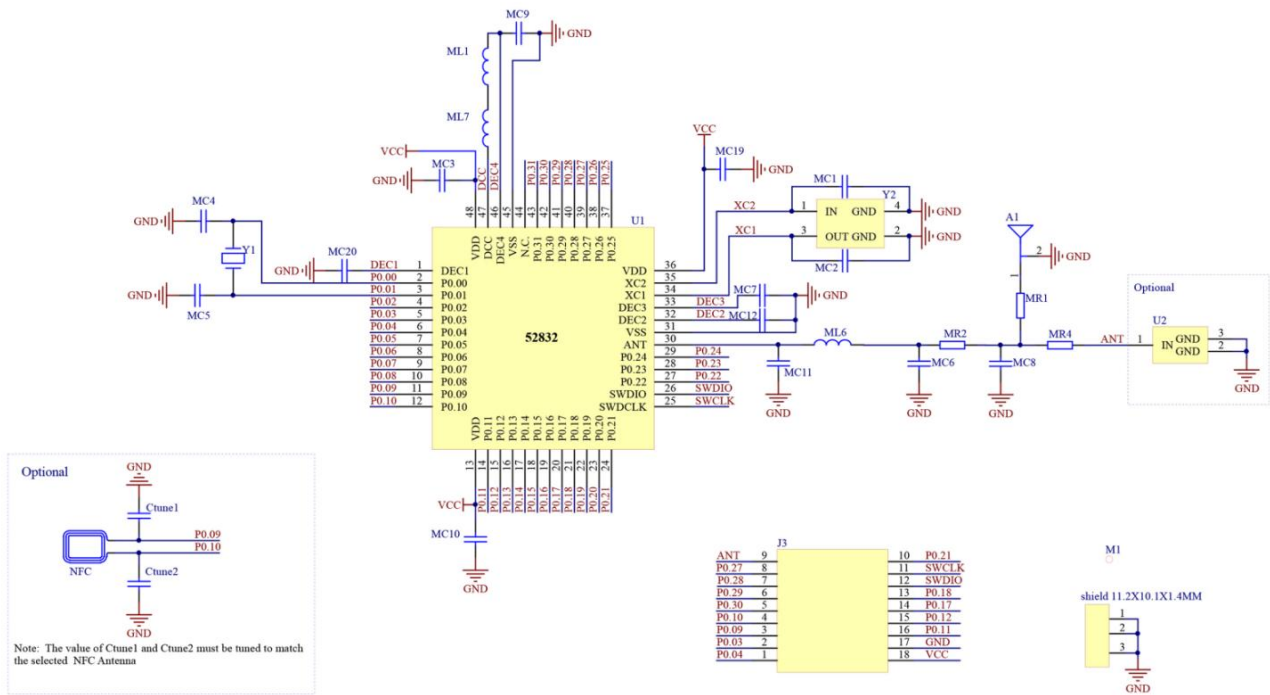

Notice: Before placing an order, please confirm the specific configuration required with the salesperson.

9 PCB Layout

Module antenna area can not have GND plane or metal cross wiring, can not be placed near the components, it is best to do skeletonization or headroom area processing, or placed on the edge of the PCB board. Reference examples are as follows

it is strongly recommended to use the first design, the module antenna design in accordance with the first wiring for debugging.

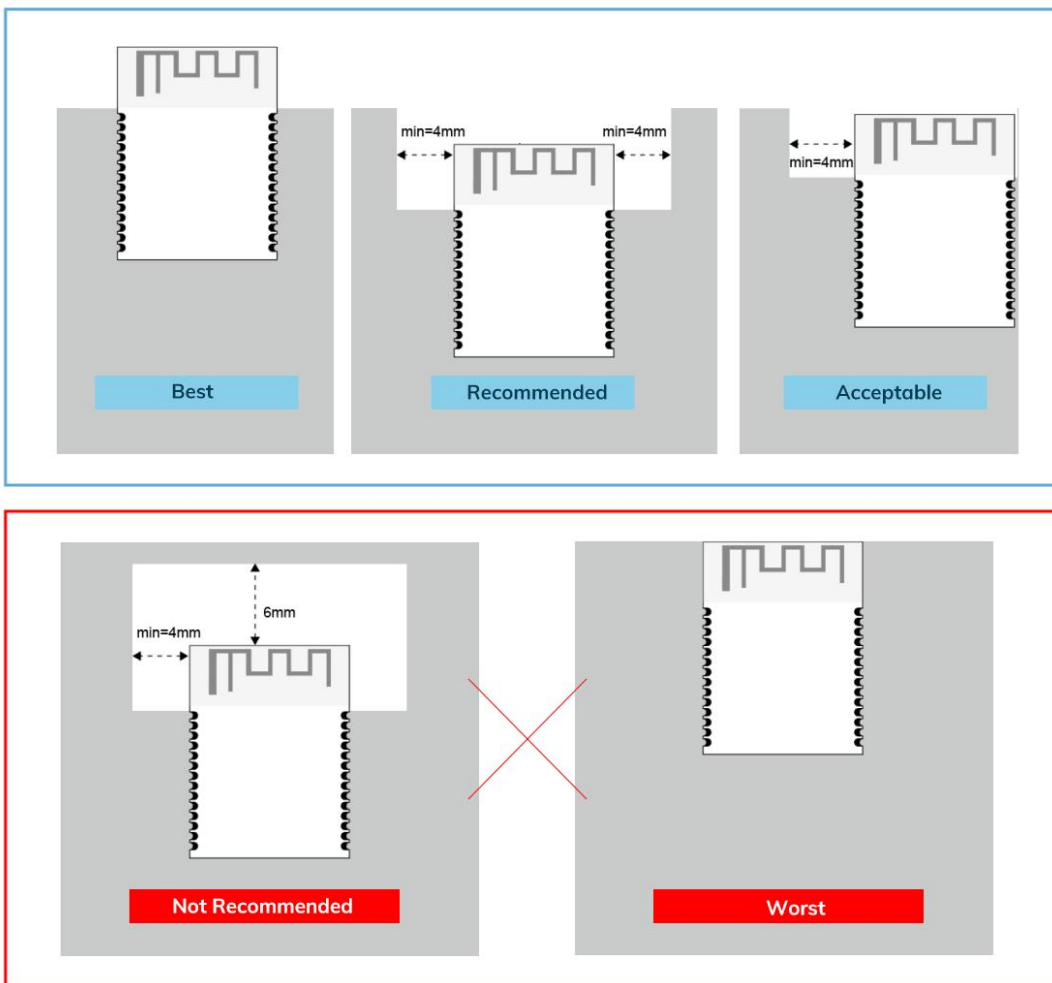

Layout notes:

- 1) Preferred Module antenna area completely clearance and not be prevented by metals, otherwise it will influence antenna's effect (as above DWG. indication).
- 2) Cover the external part of module antenna area with copper as far as possible to reduce the main board's signal cable and other disturbing.
- 3) It is preferred to have a clearance area of 4 square meter or more area around the module antenna (including the shell) to reduce the influence to antenna.
- 4) Device should be grounded well to reduce the parasitic inductance.
- 5) Do not cover copper under module's antenna in order to avoid affect signal radiation or lead to transmission distance affected.
- 6) Antenna should keep far from other circuits to prevent radiation efficiency reduction or affects the normal operation of other lines.
- 7) Module should be placed on edge of circuit board and keep a distance away from other circuits.
- 8) Suggesting to use magnetic beads to insulate module's access power supply.

10 Reflow and Soldering

- 1) Do SMT according to above reflow oven temperature deal curve. Max. Temperature is 260°C;
- 2) Refer to IPC/JEDEC standard; Peak TEMP<260°C; Times: ≤2 times, suggest only do once reflow soldering on module surface in case of SMT double pad involved. Contact us if special crafts involved.

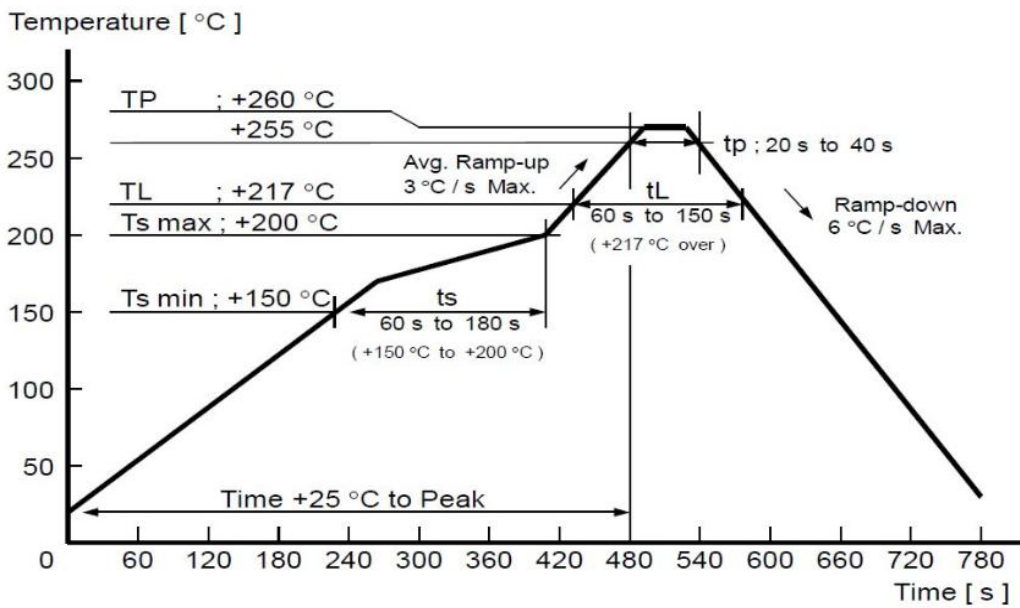

- 3)
- 4) Suggesting to make 0.2mm thickness of module SMT for partial ladder steel mesh, then make the opening extend 0.8mm
- 5) After unsealing, it cannot be used up at one time, should be vacuumed for storage, couldn't be exposed in the air for long time. Please avoid getting damp and soldering-pan oxidizing. If there are 7 to 30 days interval before using online SMT, suggest to bake at 65-70 °C for 24 hours without disassembling the tape.
- 6) Before using SMT, please adopt ESD protection measure.

11 Package Information

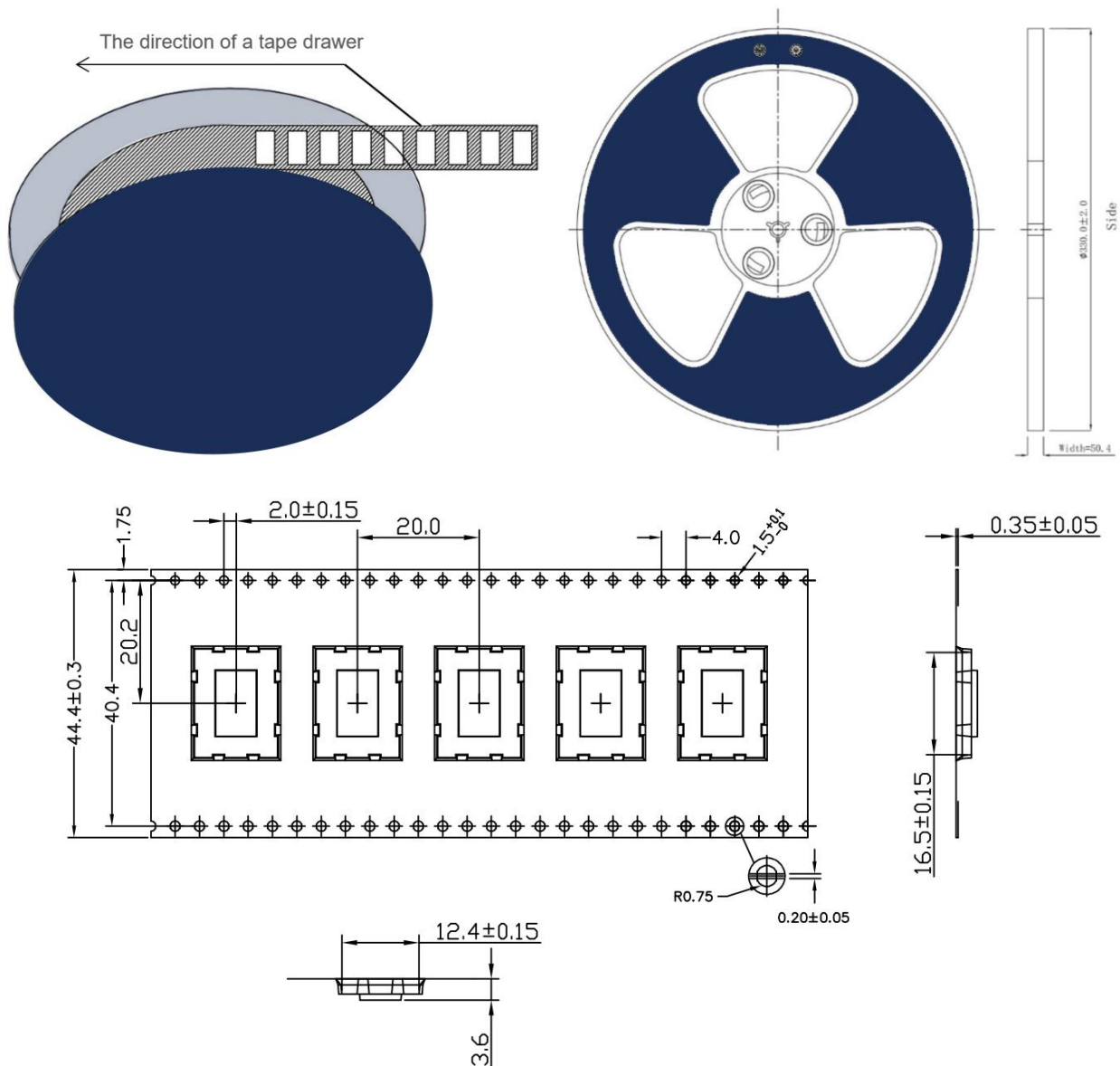

* (Default unit: mm Default tolerance: ± 0.1)

Packing detail	Specification	Net weight	Gross weight	Dimension
Quantity	850PCS	425g	1300g	W: 44mm,T:0.35mm

*** Note:** Default weight tolerance all are within 10g (except the special notes)

● Quality

The company has its own factory, advanced production equipment, and a refined quality management system. It has passed ISO9001 quality system certification, ISO14001 environmental management system certification, ISO27001 information security management system certification, OHSAS18001 occupational health and safety management system certification, and BSCI commercial and social standard certification. Each product has undergone emission power testing, sensitivity testing, power consumption testing, stability testing Strict testing such as aging testing. The fully automated modular production line has been officially put into use, with a production capacity of one million tons, meeting the needs of multi output production.

● Contact Us

Shenzhen Innovation Micro Technology Co., Ltd. always adheres to the corporate mission of "providing customers with high-quality connection modules quickly", providing you with the most timely and comprehensive services. If you need any help and support, please feel free to contact our relevant personnel or contact us as follows:

Web: www.minewsemi.com

Email: minewsemi@minew.com

Shop: <https://minewsemi.1688.com/>

Tel: +86 0755-28010353

Address: 3rd Floor,I Building, Gangzhilong Science Park, NO.6, Qinglong Road,Longhua District, Shenzhen, China

Click the icon to view and download the latest product documents electronically.



Related Documents: Chip Specification

● Copyright Statement

This manual and all the contents contained in it are owned by Shenzhen Minewsemi Co., Ltd. and are protected by Chinese laws and applicable international conventions related to copyright laws.

The certified trademarks included in this product and related documents have been licensed for use by MinewSemi. This includes but is not limited to certifications such as BQB, RoHS, REACH, CE, FCC, BQB, IC, SRRC, TELEC, WPC, RCM, WEEE, etc. The respective textual trademarks and logos belong to their respective owners. For example, the Bluetooth® textual trademark and logo are owned by Bluetooth SIG, Inc. Other trademarks and trade names are those of their respective owners. Due to the small size of the module product, the "@" symbol is omitted from the Bluetooth Primary Trademarks information in compliance with regulations.

The company has the right to change the content of this manual according to the technological development, and the revised version will not be notified otherwise. Without the written permission and authorization of the company, any individual, company, or organization shall not modify the contents of this manual or use part or all of the contents of this manual in other ways. Violators will be held accountable in accordance with the law.

MINEWSEMI

Tel: 0086-755-2801 0353

Email: minewsemi@minew.com

Web: www.minewsemi.com

Address: 3rd Floor, Building I, Gangzhilong Science Park, Qinglong Road, Longhua District, Shenzhen, 518109, China

