

# Pico Debug Carrier

## Key Features

- Dual-function RP2040 based development kit.
- Serial wire debugger carrier for the Raspberry Pi Pico development board.
- Full-fledge RP2040 development board in a standard Arduino form factor.
- Two user LEDs, power LED.
- Reset button.
- 16MB flash memory.
- USB type-C connector.

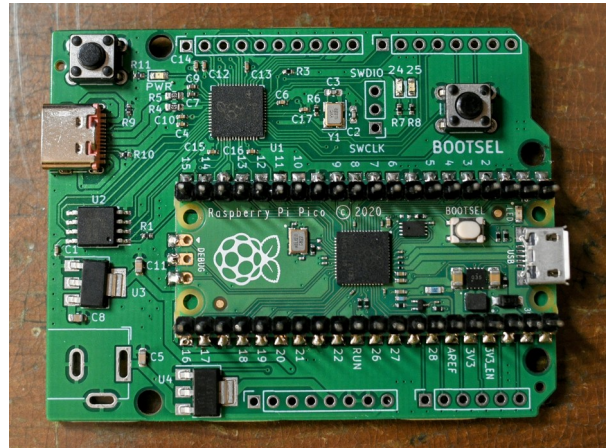

Figure 1: The Pico Debug Carrier carrying a Raspberry Pi Pico to function as a serial wire debug interface.

## Function Descriptions

The RP2040 is a powerful dual-core ARM Cortex-M0+ microcontroller designed by Raspberry Pi. This microcontroller has a rich collection of peripherals including UART, SPI, I2C and an unique PIO system. For software development, the RP2040 has SWD for debugging, and the PIO allows the RP2040 to function as a debugger for other ARM microcontrollers with SWD.

The Pico Debug Carrier(PDC for short) is designed to "carry" a Raspberry Pi Pico and act as the debugger to aid software development. The target Pico is connected to the RP2040 on the Pico Debug Carrier through both SWD and UART, enabling monitoring of STDIO while debugging.

Since only 4 GPIOs are required to function as a debugger, the rest of the GPIOs are broken out to the headers on the two sides of the PCB. In total, 24 of the 30 GPIO pins are broken out, including all 4 analogue inputs. The remaining 2 GPIOs are each connected to a user LED on the PCB. The PCB follows the form factor of the Arduino Uno, with the UART and I2C pins arranged to be at the same pin headers.

The RP2040 microcontroller supports a maximum of 16MB of flash memory. Although the Picoprobe firmware provided by Raspberry Pi is less than 2MB, we installed a 16MB flash chip just in case the user need the maximum storage when used as a development board.

There are 2 buttons on the Pico Debug Carrier, besides the BOOTSEL button for uploading binaries, a reset button is also added on the corner of the board, same as the Arduino Uno.

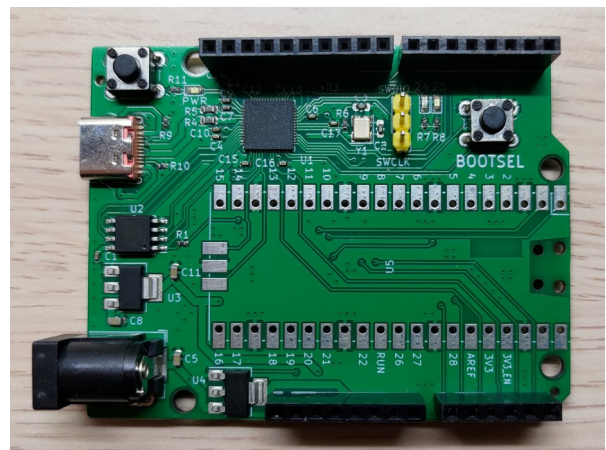

Figure 2: The Pico Debug Carrier configured as a full-fledge RP2040 development board.

## Pin Configuration and Functions

To maximise the pin compatibility with the Arduino Uno, we had to alter the order of the GPIOs on the header. The GPIOs connected to the headers are shown in figure 3. Note that the same peripheral on the RP2040 can be configured to connect to different GPIOs, meaning that the pins not listed with special functions may still be able to be configured as the desired peripherals, please refer to the [RP2040 datasheet](#) for more information.

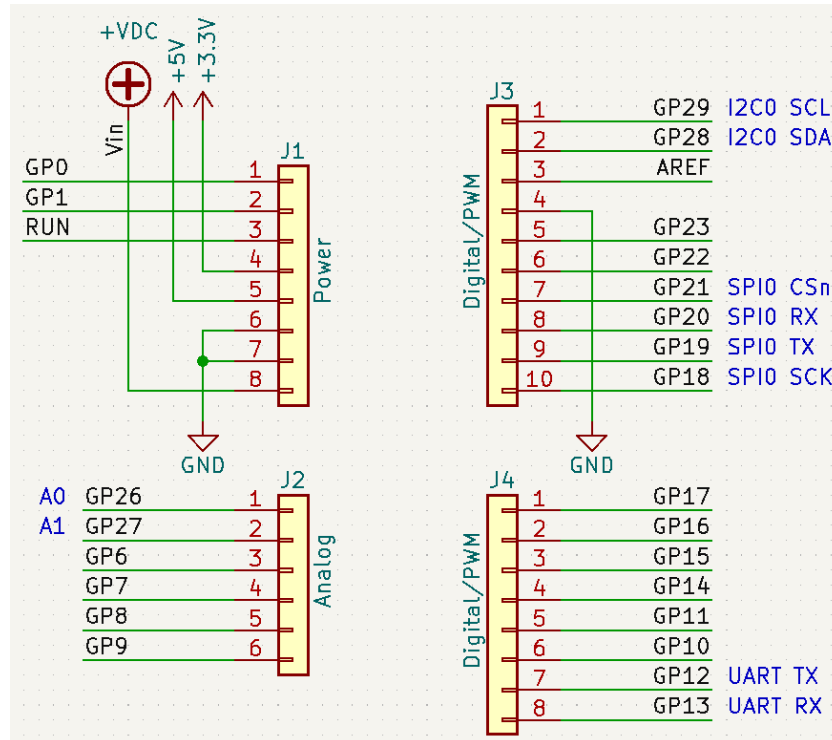

Figure 3: Pin header configuration of the Pico Debug Carrier.

Since the RP2040 has a lot more GPIOs than the ATmega 328 on the Arduino Uno, 2 pins on the power section headers are connected to GPIO 0 and 1, respectively. Other than these 2 pins, the functions of the pins remains the same as the Arduino Uno.

On the Pico Debug Carrier, only 2 of the 4 analogue input on the RP2040 is connected to the analogue section headers. The remaining two (GPIO28 & GPIO29) are connected to the top right headers.

The lower right headers are not in order. GPIO12 and 13 are placed in reverse to keep UART RX and TX at the same physical pin as the Arduino Uno.

## Jumper Pad Configurations

There are a total of 4 jumper pads on the bottom side of the Pico Debug Carrier, which are used for hardware configuration of the board.

Jumper Pad #	Function	Default
JP1	Bypass 5V linear regulator and feed the DC input from the Vin pin and the barrel jack straight into the	Open

	3.3V linear regulator. Note that if shorted, the 5V pin will at the voltage of $V_{in}$ .	
JP2	Connects the onboard 3.3V linear regulator to the ADC_VDD on the RP2040. Note that if opened, the ADC will not function without external supply to the AREF pin.	Short
JP3	Connects the onboard 5V linear regulator to the VBUS pin the target Pico. Short this jumper pad to provided power to the USB port on the target Pico from the Pico Debug Carrier.	Open
JP4	Connects the 3V3_EN pin on the target Pico to ground. Short this solder pad to disable the buck(boost) converter on the target Pico.	Open

### ***Debug Carrier Setup Guide***

The Pico Debug Carrier offers an SMD footprint to mount the Raspberry Pi Pico development board. Once mounted, the PDC can be loaded with the Picoprobe firmware and debug the target Pico. There are also THT pins to mount pin headers on the 40 pins around the Raspberry Pi Pico, offering full access to the GPIO pins on the target Pico. Installing the target Pico requires soldering pin headers through two PCBs, please follow the guide below for easier soldering process.

1. Place the Pico and the headers on the two sides onto the PCB and solder the 3 debug pins to secure the target Pico, see figure 4.
2. Flip to the other side and solder the pin headers, see figure 5. Apply a little bit of solder to heat up both the pin and the pad, and then add more solder to cover the whole pin. It is recommended to use longer pin headers such as 15mm ones. However, 12mm pin headers will just work as in the figure.
3. Solder the SMD pads (figure 6) on the front side of the PCB to connect the rest of the GPIOs on the Pico to the PDC. This is required to make the connection between the target Pico and the pin headers, since the pin headers are soldered to the PDC.

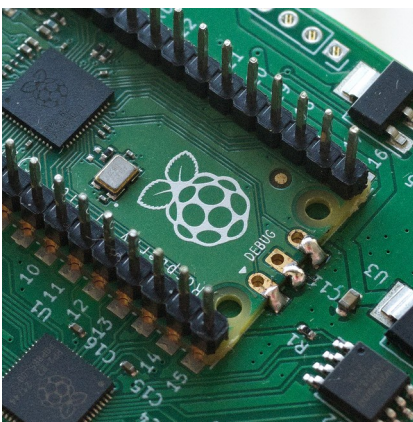

Figure 4: Solder debug pins.

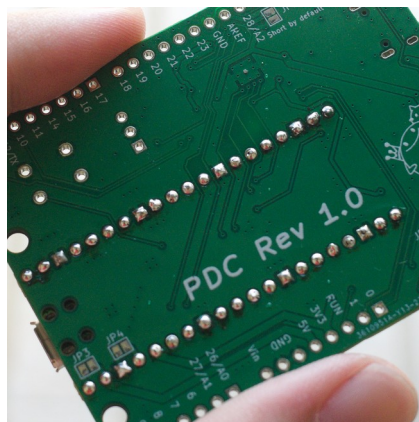

Figure 5: Solder pin headers.

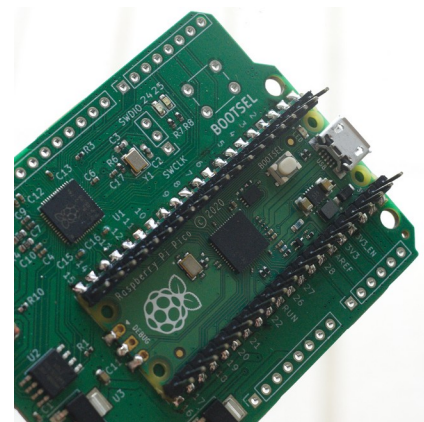

Figure 6: Solder SMD pads.

4. Solder the DC jack, 2 buttons and female headers if needed. These parts are not necessary for the operation of the debug carrier.
5. Upload the [Picoprobe](#) firmware. When booting up the first time, the RP2040 will go into BOOTSEL mode automatically. Therefore, if we only want to upload the Picoprobe firmware and not change it, we don't actually need the BOOTSEL button.

Once the firmware is uploaded, the green user LED connected to GPIO25 on the PDC should be illuminated. For more information about setting up the software to get started with debugging, please refer to [the excellent video made by Digi-Key](#).

### ***List of Parts***

Parts	Bare PCB	Basic kit	Full kit
Pico Debug Carrier PCB	included (1x)	included (1x)	included (1x)
2.1mm DC barrel jack	not included	included (1x)	included (1x)
3-pin debug headers	not included	included (1x)	included (1x)
6x6mm THT buttons	not included	included (2x)	included (2x)
6-pin female headers	not included	included (2x)	included (2x)
8-pin female headers	not included	included (1x)	included (1x)
10-pin female headers	not included	included (1x)	included (1x)
Raspberry Pi Pico	not included	not included	included (1x)
20-pin 15mm headers	not included	not included	included (2x)

### ***Document Revision History***

Revision	Changelog
1.0	Initial revision.

