

USB-C Power Supply Kit Multi

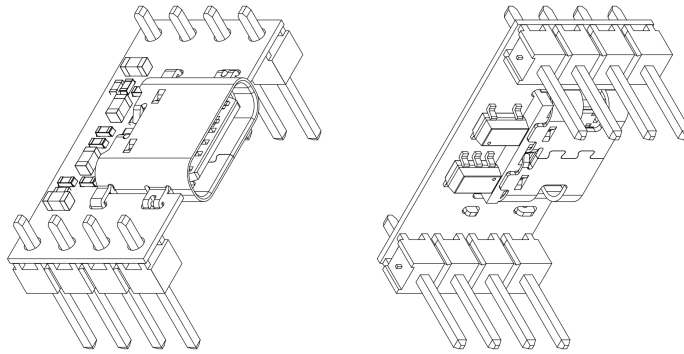

Description

This kit supports 5.0V, 3.3V and 1.8V and all outputs can be used at the same time. This is very practical if multiple voltage sources are needed in a Breadboard Project.

The small form factor is designed to fit into most commonly used 2.54mm (0.1") Breadboards.

The 5.0V output is unregulated and depends on the input voltage given from the connected USB device.

The maximum output current is 300mA per voltage regulator. The maximum output power of the Kit is 15W.

The design is based on the AP2127¹ from Diodes Incorporated. The adjustable version is used, to be able to adjust the output voltage on the fly. This circuit can very well be used with other adjustable low-dropout regulators or with adjustable LDO's from other manufacturers.

This Kit has been created for engineers, hackers and other technical people to simplify the circuit prototyping process and to always have a fitting USB power supply on hand.

Features

- USB-C Connector
- Two Voltage Regulators
- Supports 5.0V, 3.3V and 1.8V at the same time
- 3.3V and 1.8V output with 300mA
- Maximum Output Power 15W
- Short Circuit Protection
- Over Temperature Protection
- High Ripple Rejection:
68dB @ f = 1kHz, 54dB @ f = 10kHz
- Small size: 20mm x 10mm

Outputs

- 5.0V @3A
- 3.3V @300mA
- 1.8V @300mA

¹Diodes Incorporated AP2127

Application Information

Getting Started

The Contents of the Kit are the following:

- 1x PCB with SMD components pre-assembled
- 2x Pin Headers 2.54mm 1x4

To get started, you need to assemble the kit by soldering the pin headers to the PCB. The easiest way is to plug the pin headers into the breadboard and then put the PCB on them. By doing this the PCB is held in place while soldering.

Overview

On the top side is the USB Connector and some passive components. On the top side silkscreen the outputs are labeled.

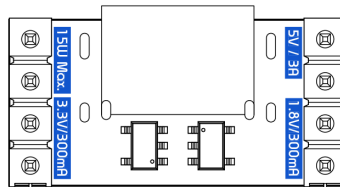
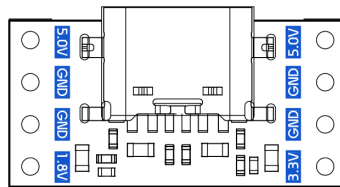

On the bottom side there are the voltage regulators and the 2.54mm output connectors. The bottom silk screen has some additional information on the maximal output current and power.

Usage Information

The three outputs can be used at the same time, but the maximal output power shouldn't be exceeded. If the 1.8V and 3.3V outputs are used with maximal output current (300mA each), the 5.0V output can only be used to draw 2.7A. This is because the maximum output power is 15W and using the 1.8V and 3.3V outputs with maximum output power adds up to roughly 1.5 Watts, therefore the remaining 13.5W results in a current of 2.7A on the 5V output.

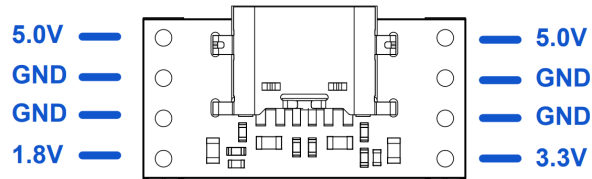

The maximal output power of 15W can only be used if the connected USB device supports the output power of 15W. If a common USB power source is used that does not support higher power modes it can usually output 2.5W.

Mechanical Drawing

The board is sized 20.32mm x 10mm with THT 2.54mm 1x4 connectors on each side. The spacing between the 2.54mm THT connectors is 17.78mm (0.7") to fit the most common breadboards.

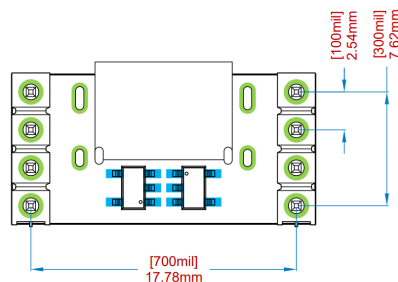
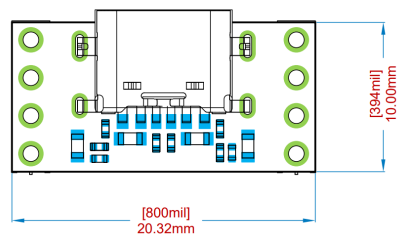

Electrical Characteristics

Symbol	Description	Value	Unit
U_{OUT}	Output Voltage Options	1.8, 3.3, 5.0	V
I_{5V0}	Output Current ($U_{OUT} = 5.0V$)	3	A
I_{3V3}	Output Current ($U_{OUT} = 3.3V$)	300	mA
I_{1V8}	Output Current ($U_{OUT} = 1.8V$)	300	mA
P_{5V0}	Output Power ($U_{OUT} = 5.0V$)	15	W
P_{3V3}	Output Power ($U_{OUT} = 3.3V$)	1	W
P_{1V8}	Output Power ($U_{OUT} = 1.8V$)	540	mW
I_Q	Quiescent Current ($I_{OUT} = 0mA$)	180	μA
I_{SHORT}	Short Current Limit ($U_{OUT} = 0V$)	50	mA
$PSRR$	Power Supply Rejection Ratio	45 - 68	dB
U_{NOISE}	RMS Output Noise	60	μV_{RMS}

Absolute Maximum Ratings

Symbol	Description	Value	Unit
P_{TOT}	Total Power Output	15	W
U_{IN}	Input Voltage	6.5	V
T_J	Junction Temperature	150	$^{\circ}C$

Recommended Operation Conditions

Symbol	Description	Min	Max	Unit
U_{IN}	Input Voltage	4.75	6.0	V
T_A	Ambient Temperature	-10	+50	$^{\circ}C$

Revisions

Description	Version	Date
Initial Document Release	1.00	July 2023