

# ULN 2xxx

## 2x unipolar stepper motor driver

### ULN2803 / ULN2003

hardware and software solutions  
dream your robots

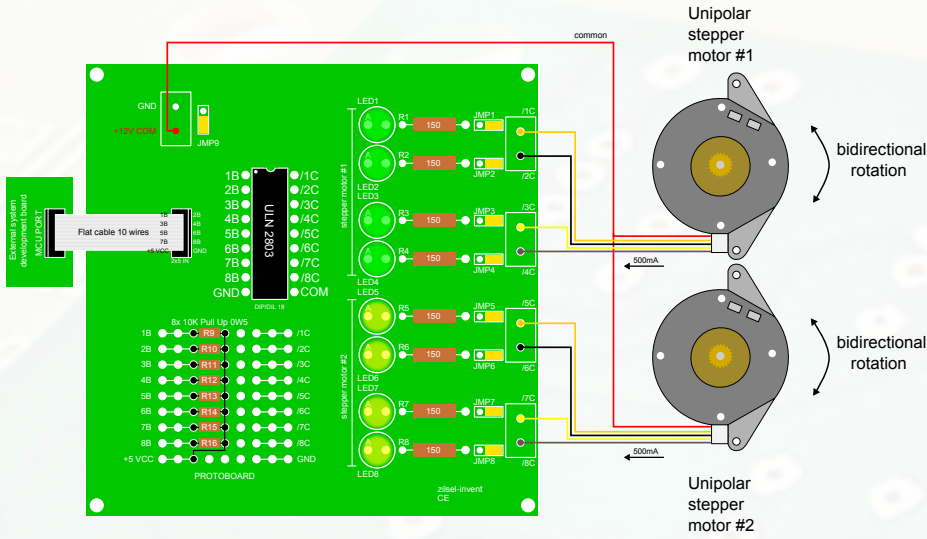

#### Example #1 (left)

**ULN2803 TTL / 5V CMOS**  
**2x Unipolar stepper motor (4+1 wires) +12V**

**Wires connection:**  
Red motor wire (common) is connected to COM, control wires (coils) are connected to screw connector.

**Jumpers configuration JMP1 - JMP4:**  
Green LED matrix active: NO  
Unipolar stepper motor #1 active: YES

**Jumpers configuration JMP5 - JMP8:**  
Yellow LED matrix active: NO  
Unipolar stepper motor #2 active: YES

**8x Pull Up 10K Resistors**  
Use the prototype panel to add 8 additional resistors for each of the eight Darlington transistor channels.

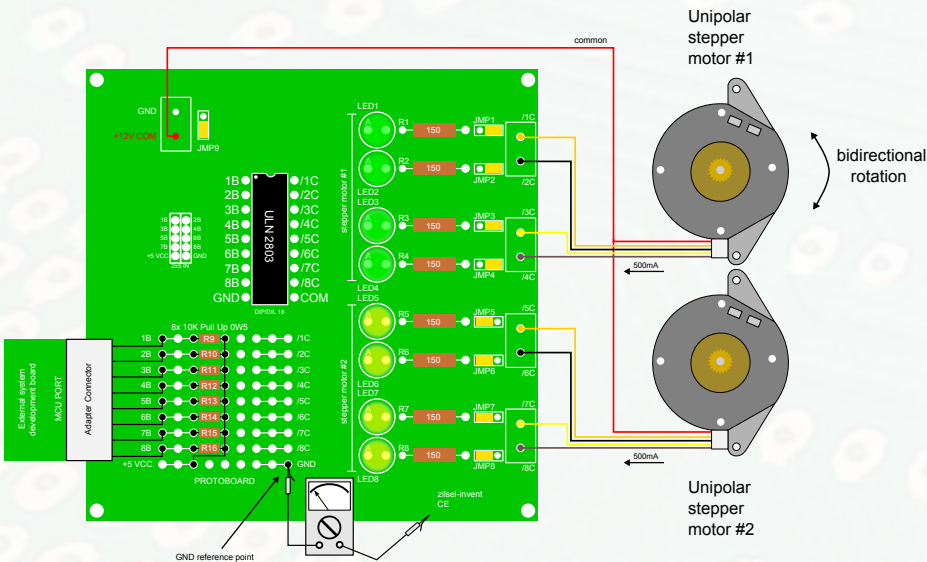

#### Example #2 (left)

**Jumpers configuration JMP1 - JMP4:**  
Green LED matrix active: NO  
Unipolar stepper motor #1 active: YES

**Jumpers configuration JMP5 - JMP8:**  
Yellow LED matrix active: YES  
Unipolar stepper motor #2 active: NO

**Connection**  
If your system development board does not have 2x5 input pin head male connector, use the prototype panel to build adapter connector.

**GND reference point**  
Make measuring easier. Solder pin head connector to the GND reference point of the prototype panel. Use crocodile clips to connect the measuring instrument to the GROUND (GND) reference point. One hand remains free for other tasks!

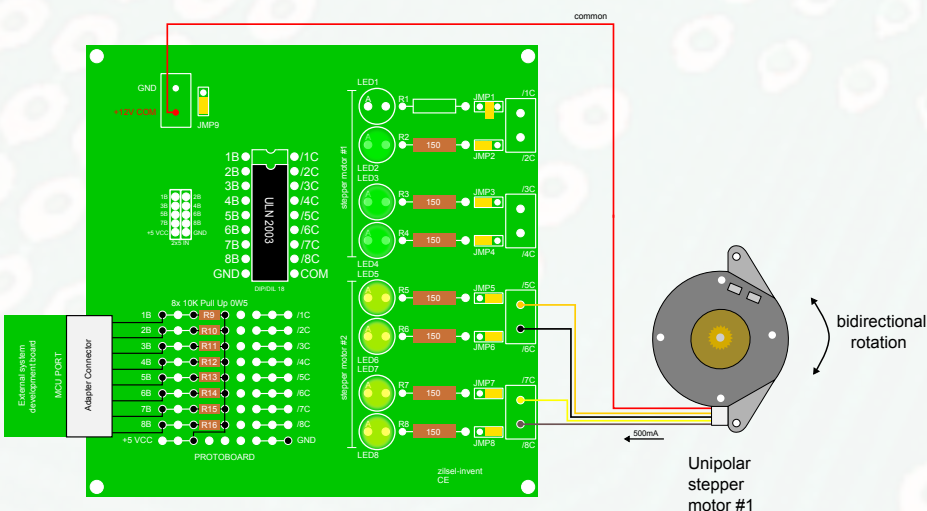

#### Example #3 (left)

**7-Channels driver**  
**ULN2003 TTL / 5V CMOS**

Available seven channels, 1B/1C is inactive. Unipolar stepper motor connected to the last four pins of the Darlington driver ULN2003. Identical connection for B12xxx series.

**Jumpers configuration JMP2 - JMP4:**  
Green LED matrix active: YES, only 3 channels.

**Jumpers configuration JMP5 - JMP8:**  
Yellow LED matrix active: NO  
Unipolar stepper motor #1 active: YES

**Remarks:** The examples relate to the DC motors rated at 12V and ≤ 500mA, LED and resistor values are calculated regarding TTL / 5V CMOS logic families.  
**Before using, be sure to consult the manufacturer's documentation/specification of DC motors / ULN2xxx / BA12xxx IC circuits.**