

Arduino 4xVideo Shield Rev2

Designed by Wolfgang Friedrich

Released under Attribution-ShareAlike 4.0 International (CC BY-SA 4.0)

<https://hackaday.io/project/170499-vga-shield-wing>

<https://www.tindie.com/products/pier42/4x-video-display-arduino-shield-feather-wing/>

<https://github.com/wolfgangfriedrich/P42-VGA>

Table of Contents

Table of Contents.....	2
Introduction.....	4
Hardware.....	5
Use different SPI chip select pins.....	5
SPI over ICPS header.....	5
Flash Memory.....	6
Memory Map.....	6
Program FLASH with character bitmap.....	7
Library Functions.....	7
Resolutions.....	7
Constants.....	8
Color Palette.....	8
Control Functions.....	9
P42Display().....	9
Config().....	9
SPIReadRegister ().....	9
SPIReadRegister16 ().....	10
SPIWriteRegister ().....	10
SPIWriteRegister16 ().....	10
SPIWriteRegister32 ().....	11
SPIWriteRegister40 ().....	11
SPIReadByte ().....	12
SPIReadWord ().....	12
SPIWriteByte ().....	12
SPIWriteWord ().....	13
Graphics commands.....	13
ClearScreen ().....	13
FilledRectangle ().....	13
SetRGBPixel ().....	14
SetYUVPixel ().....	14
PrintChar ().....	14
PrintString ().....	15
YUV Palette.....	16
8-Bit Default Palette.....	16
NTSC/PAL Color Conversion Tool.....	16

Video Signal Information	16
Revision Control.....	18

Introduction

The Video4 Display Shield is an expansion board for the Arduino and Feather Platforms.

This board provides up to 4 analog composite video display interfaces with integrated frame buffer memory accessible through SPI. The 4 video outputs are accessible through 1 RCA connector and 1 VGA DB15-HD connector that uses the red, green and blue channels for the composite signal.

PAL and NTSC output formats are supported; display resolutions range from 320x200 with 65536 colours up to 720x576 with reduced colour count. It can be ordered as NTSC version with a 3.579545 MHz crystal or as PAL version with 4.43618 MHz crystal. Currently 2 resolutions are implemented: NTSC 320x200 with 256 colours or PAL 300x240 with 256 colours. The heart of this design is the VLSI VS23S040 chip, which is able to output 4 composite video with resolutions from 320x200 in 65536 colours to 720x576 in 4 colours. The chip has a 1Mbit framebuffer per channel, unused memory can be used for graphics tiles, which can be copied into the image data by the internal fast memory block move hardware.

A 16 Mbit SPI FLASH memory is available on-board. It is pre-loaded with a character bitmap consisting of 94 characters (ASCII code 33-126). A SOIC-8 footprint for an I2C EEPROM is also on board, but not populated.

The board uses the Arduino IOREF voltage to translate between 3.3V on the shield side and the respective IO voltage on the Arduino side. So this shield works together with UNO, MEGA, DUE and also with any 3.3V system that uses the Arduino form factor and pinout, without modifications.

The board also has an option for Feather Wing headers. If the Feather Wing connector option extends on the bottom of the shield, this would interfere mechanically with an Arduino Stack. A special set of connectors can be ordered, which I will be soldering on the board. The Feather controller board need so have male pin header on its bottom to be able to mount to this wing configuration.

Specifications:

- Operating supply voltage 4.5 V – 20 V
- Board IO voltage (IOREF) 1.65 V - 5.5 V
- 4x Composite Video Output
- Maximum resolution 720x576 in 4 colours
- Implemented resolutions: NTSC 320x200 with 256 colours and PAL 300x240 with 256 colours
- Crystal: NTSC 3.579545 MHz or PAL 4.43618 MHz
- Communication interface: SPI up to 38 MHz
- Video Frame Buffer: 4x 1 Mbit = 4x 128 KByte
- Flash: 16 Mbit = 2 MByte
- EEPROM: up to 2Mbit (optional, not populated)
- IO connectors Arduino Uno and Adafruit Feather compatible
- Size: 85mm x 53mm (3.3" x 2.1")

Hardware

The Video Display Shield is designed for the Arduino Uno, but also runs on the Mega and Due. There is also an optional connection options for the Adafruit Feather form factor.

The 4 video channels are mapped as following:

Video Channel	Hardware Mapping
0	RCA port
1	VGA blue
2	VGA green
3	VGA red

A 16Mbit SPI FLASH memory is available, preloaded with character bitmap data, and 2 graphics demos.

Use different SPI chip select pins

If more SPI devices are used, the use of the slave select signals needs to be coordinated. This shield uses Arduino pins 10 for the controller chip select and 9 for the Flash chip select. Modifications by cutting traces and adding wires should only be performed when you know what you are doing.

SPI over ICSP header

To make the board compatible to the hardware SPI interfaces on the Arduino Mega and Due, the SPI interface is connected through the ICSP header.

Pros:

- Mega and Due can make use of the hardware SPI interface and do not have to software bit-bang implementation, which is slow and takes away computing resources.
- Connection works by simply plugging it in without extra wires for the hardware interface.

Cons:

- The Video4 board has to be the 1st board in a board stack to access the ICSP header.

For uses cases, that cannot access the ICPS port, 3 additional 0 Ω resistors R29, R30, R31 can be soldered to the board and the SPI interface is routed through the regular IO headers on pin 11, 12, 13 for the UNO header and pins 14, 15, 16 for the Feather header. Please consult the schematics for details.

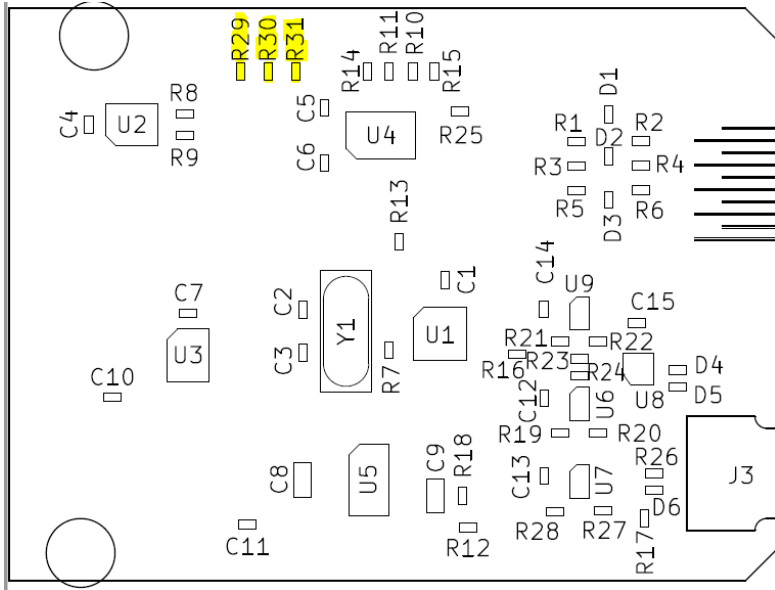

Flash Memory

Memory Map

By default the 16 Mibit (2 MiByte) Flash memory is used as follows:

Memory Bytes		Description
0 - 751	0x00000-0x002EF	94 letters each 8 byte
752 - 4095	0x002F0-0x00FFF	empty
4096 - 12287	0x01000-0x02FFF	8 frames 32x32 byte for BoingBall demo
12287 - 262144	0x03000-0x04FFF	BMP image for picture demo
	0x05000-0x3FFFF	empty

Program FLASH with character bitmap

See <https://hackaday.io/project/21097/instructions> for details.

Here is an ASCII character table for the symbols programmed in Flash by default

Dec	Hex	Char	Dec	Hex	Char	Dec	Hex	Char	Dec	Hex	Char
33	21	!	57	39	9	81	51	Q	105	69	i
34	22	"	58	3A	:	82	52	R	106	6A	j
35	23	#	59	3B	;	83	53	S	107	6B	k
36	24	\$	60	3C	<	84	54	T	108	6C	l
37	25	%	61	3D	=	85	55	U	109	6D	m
38	26	&	62	3E	>	86	56	V	110	6E	n
39	27	'	63	3F	?	87	57	W	111	6F	o
40	28	(64	40	@	88	58	X	112	70	p
41	29	0	65	41	A	89	59	Y	113	71	q
42	2A	*	66	42	B	90	5A	Z	114	72	r
43	2B	+	67	43	C	91	5B	[115	73	s
44	2C	,	68	44	D	92	5C	\	116	74	t
45	2D	-	69	45	E	93	5D]	117	75	u
46	2E	.	70	46	F	94	5E	^	118	76	v
47	2F	/	71	47	G	95	5F	_	119	77	w
48	30	0	72	48	H	96	60	`	120	78	x
49	31	1	73	49	I	97	61	a	121	79	y
50	32	2	74	4A	J	98	62	b	122	7A	z
51	33	3	75	4B	K	99	63	c	123	7B	{
52	34	4	76	4C	L	100	64	d	124	7C	
53	35	5	77	4D	M	101	65	e	125	7D	}
54	36	6	78	4E	N	102	66	f	126	7E	~
55	37	7	79	4F	O	103	67	g			
56	38	8	80	50	P	104	68	h			

Library Functions

Resolutions

Currently implemented are

PAL 300x240 8bit

NTSC320x200 8bit

How to select an implemented resolution, please see chapter "Config()" on page 9. Other resolutions will be available in the future.

Possible Resolutions are (copied from the VLSI VS23S040 datasheet):

Resolution	H	V	Pixels	Colors ¹	Bits per pixel	Memory bytes
NTSC YUV422 ²	352	240	84480	65536	8+4	126720
MCGA	320	200	64000	65536	16	128000
CDG	300	216	64800	65536	16	129600
QVGA	320	240	76800	8192	13	124800
NTSC VCD	352	240	84480	4096	12	126720
PAL VCD	352	288	101376	1024	10	126720
NTSC noninterlaced	440	243	106920	512	9	120285
PAL noninterlaced	520	288	149760	128	7	131040
HVGA	480	320	153600	64	6	115200
EGA	640	350	224000	16	4	112000
VGA letterbox	640	400	256000	16	4	128000
NTSC Analog	440	486	213840	16	4	106920
NTSC SVCD	480	480	230400	16	4	115200
NTSC DVD	720	480	345600	8	3	129600
VGA	640	480	307200	8	3	115200
PAL Analog	520	576	299520	8	3	112320
PAL SVCD	480	576	276480	8	3	103680
PAL DVD	720	576	414720	4	2	103680

Implementation of the current resolutions was greatly supported by VLSI Solutions <http://www.vlsi.fi/en/home.html> as part of demo code for the VS23S010D-L chip.

For more information see:

<http://www.vsdsp-forum.com/phpbb/viewforum.php?f=14>

<http://www.vlsi.fi/en/products/vs23s010.html>

https://webstore.vlsi.fi/epages/vlsi.sf/en_GB/?ObjectID=13893093

Constants

The following constants are provided by the library. They are useful to make the code adapting to other resolutions.

Name	Description
XPIXELS	X size of the picture area
YPIXELS	Y size of the picture area

Color Palette

The colour palette is defined as part of the controller configuration. It is described in good detail by a series of forum posts on the VLSI website:

[Nice color palettes for VS23S010 TV-Out](#)

[Understanding Protolines and Line Pointers](#)

Also a handy table to pick colours by their 8 bit YUV value is located in chapter “8-Bit Default Palette”

Control Functions

P42Display()

Board and SPI interface configuration.

Pin	Pin Nr	Direction	Default	Description
MVBLK	6	In	X	Ready signal after Block Move Command
nWP	7	Out	High	Write Protect for Flash Memory and Video Controller
nHOLD	8	Out	High	Hold signal for SPI interface
nMemSelect	9	Out	High	SPI Select for Flash Memory
nSlaveSelect	10	Out	High	SPI Select for Video Controller

Config()

Full configuration of the video controller including protolines, picture lines and video resolution.

```
word Config( byte channel );
```

Value	Size	Description
channel	byte	Channel # to be configured, can be from 0 to 3
return value	word	Content of the Device ID register for the selected channel

Example: Configure channel 0

```
Result = P42Display.Config ( CH0 );
```

The resolution is set in the VS23S040D.h file by removing the comment of the desired resolution:

```
// *** Select Video Resolution here ***  
#define NTSC320x200  
//#define PAL300x240
```

Here NTSC320x200 is selected.

SPIReadRegister ()

Read an 8bit register value from the video controller.

```
byte SPIReadRegister (byte address, boolean debug);
```

Value	Size	Description
address	byte	Opcode of the video controller command, also called register address
debug	boolean	Define if the address and return value will be written to a serial debug port. The debug port needs to be configured in the setup() routine, e.g. Serial.begin(115200);
return value	byte	Result of the read command

Example: Read Manufacturer and Device ID register (8bit)

```
Result = P42Display.SPIReadRegister (ReadDeviceID, true);  
⇒ Result will be 0x2B.
```

Debug output will be: "SPI address: 0x9F : 0x2B"

SPIReadRegister16 ()

Read a 16bit register value from the video controller.

```
word SPIReadRegister16 (byte address, boolean debug);
```

Value	Size	Description
address	byte	Opcode of the video controller command, also called register address
debug	boolean	Define if the address and return value will be written to a serial debug port. The debug port needs to be configured in the setup() routine, e.g. Serial.begin(115200);
return value	byte	Result of the read command

Example: Read Manufacturer and Device ID register (16bit)

```
Result = P42Display.SPIReadRegister (ReadDeviceID, false);  
⇒ Result will be 0x2B00.
```

No debug output.

SPIWriteRegister ()

Write an 8bit value to a register in the video controller.

```
void SPIWriteRegister (byte address, byte value, boolean debug);
```

Value	Size	Description
address	byte	Opcode of the video controller command, also called register address
value	byte	Register value to be written into the given register address
debug	boolean	Define if the address and register value will be written to a serial debug port. The debug port needs to be configured in the setup() routine, e.g. Serial.begin(115200);

Example: Write GPIO Control Register

```
P42Display.SPIWriteRegister( WriteGPIOControl, PI04Dir | PI04High, false );
```

SPIWriteRegister16 ()

Write a 16bit value to a register in the video controller.

```
void SPIWriteRegister16 (byte address, word value, boolean debug);
```

Value	Size	Description
address	byte	Opcode of the video controller command, also called register address
value	word	Register value to be written into the given register address
debug	boolean	Define if the address and register value will be written to a serial debug port. The debug port needs to be configured in the setup() routine, e.g. Serial.begin(115200);

Example: Write left limit of visible picture

```
SPIWriteRegister16 (WritePictureStart, STARTPIX-1, false );
```

SPIWriteRegister32 ()

Write a 32bit value to a register in the video controller.

```
void SPIWriteRegister32 (byte address, unsigned long value, boolean debug);
```

Value	Size	Description
address	byte	Opcode of the video controller command, also called register address
value	unsigned long	Register value to be written into the given register address
debug	boolean	Define if the address and register value will be written to a serial debug port. The debug port needs to be configured in the setup() routine, e.g. Serial.begin(115200);

Example: Write microcode

```
SPIWriteRegister32 (WriteProgram, ((OP4 << 24) | (OP3 << 16) | (OP2 << 8) | (OP1)), false );
```

SPIWriteRegister40 ()

Write a 40bit value to a register in the video controller. The 40bit value is split into 2x 16bit plus one 8bit parameter for a more intuitive and readable code. Only the 'Block Move Control 1' register is 40bit wide, so the parameters are conveniently named for the register only.

```
void SPIWriteRegister40 (byte address, word source, word target, byte control, boolean debug );
```

Value	Size	Description
address	byte	Opcode of the video controller command, also called register address
source	word	Source memory address for the block move command
target	word	Target memory address for the block move command
control	word	Control bits for block move and DAC output
debug	boolean	Define if the address and register value will be written to a serial debug port. The debug port needs to be configured in the setup() routine, e.g. Serial.begin(115200);

Example: Enable PAL Y lowpass filter

```
SPIWriteRegister40 (WriteBlockMoveControl1, 0x0000, 0x0000, BMVC_PYF, false );
```

SPIReadByte ()

Read an 8bit value from the SRAM video buffer memory in the video controller.

byte SPIReadByte (byte channel, unsigned long address);

Value	Size	Description
channel	byte	Channel # to be configured, can be from 0 to 3
address	unsigned long	video buffer memory address
return value	byte	Result of the read command

Example: Read address 0 from channel 1

```
Byte1 = SPIReadByte ( CH1, 0x00000000 );
```

SPIReadWord ()

Read a 16bit value from the SRAM video buffer memory in the video controller.

word SPIReadByte (byte channel, unsigned long address);

Value	Size	Description
channel	byte	Channel # to be configured, can be from 0 to 3
address	unsigned long	video buffer memory address
return value	word	Result of the read command

Example: Read address 0 from channel 2

```
Word1 = SPIReadWord ( CH2, 0x00000000 );
```

SPIWriteByte ()

Write an 8bit value to the SRAM video buffer memory in the video controller.

void SPIWriteByte (byte channel, unsigned long address, byte value, boolean debug);

Value	Size	Description
channel	byte	Channel # to be configured, can be from 0 to 3
address	unsigned long	video buffer memory address
value	byte	Data value to be written into the given memory address
debug	boolean	Define if the address and memory value will be written to a serial debug port. The debug port needs to be configured in the setup() routine, e.g. Serial.begin(115200);

Example: Write a YUV data value to a specific x,y coordinate to channel 3

```
SPIWriteByte ( CH3, PICLINE_BYTE_ADDRESS(y) + x, YUVdata, false);
```

SPIWriteWord ()

Write a 16bit value to the SRAM video buffer memory in the video controller.

```
void SPIWriteWord (byte channel, unsigned long address, word value, boolean debug );
```

Value	Size	Description
channel	byte	Channel # to be configured, can be from 0 to 3
address	unsigned long	video buffer memory address
value	word	Data value to be written into the given memory address
debug	boolean	Define if the address and memory value will be written to a serial debug port. The debug port needs to be configured in the setup() routine, e.g. Serial.begin(115200);

Example: Clear entire video buffer channel 0 memory (everything not only the picture data area!)

```
for ( i=0; i < 65536; i++)  
    SPIWriteWord ( CH0, i, 0x0000, false);
```

Graphics commands

ClearScreen ()

Clear the video screen by filling the framebuffer memory with a given colour value. The colour can be picked from the default colour table in chapter "8-Bit Default Palette".

```
void ClearScreen ( byte channel, byte colour );
```

Value	Size	Description
channel	byte	Channel # to be configured, can be from 0 to 3
colour	byte	YUV colour value picked from default palette

Example: Clear screen and set to a light blue background colour for channel 0.

```
P42Display.ClearScreen ( CH0, 0x5c );
```

FilledRectangle ()

Draw a filled rectangle into the video buffer. This function was re-used from the Arduino demo provided by VLSI. See here for details: <http://www.vsdsp-forum.com/phpbb/viewtopic.php?f=14&t=2172>

The colour can be picked from the default colour table in chapter "8-Bit Default Palette".

```
void FilledRectangle (byte channel, u_int16 x1, u_int16 y1, u_int16 x2, u_int16 y2, u_int16 color);
```

Value	Size	Description
channel	byte	Channel # to be configured, can be from 0 to 3
x1	u_int16	x coordinate of top left corner of the rectangle
y1	u_int16	y coordinate of top left corner of the rectangle
x2	u_int16	x coordinate of bottom right corner of the rectangle
y2	u_int16	y coordinate of top bottom right of the rectangle
color	u_int16	YUV colour value picked from default palette. Only the lower 8 bit are used

	for colour information.	
--	-------------------------	--

Example: Draw a 10 pixel by 10 pixel square in the top left corner of the screen in yellow colour on channel 0.
`P42Display.FilledRectangle (CH0, 0, 0, 9, 9, 0xBF);`

SetRGBPixel ()

This is an experimental function and should not be used for now. Eventually it will perform a RGB-to-YUV conversion depending on the colour space of the given colourspace.

Draw a pixel on the screen at the given coordinates.

The colour is a 32 bit unsigned integer of the format 0x00RRGGBB representing a 24bit RGB value.

```
void SetRGBPixel (byte channel, word x, word y, unsigned long colour);
```

Value	Size	Description
channel	byte	Channel # to be configured, can be from 0 to 3
x	word	x coordinate of the pixel
y	word	y coordinate of the pixel
colour	unsigned long	32 bit unsigned integer of the format 0x00RRGGBB representing a 24bit RGB value

Example: Draw a yellow pixel at the coordinates on channel 0.

```
P42Display.SetRGBPixel ( CH0, 314, 159, 0x00FFFF00 );
```

SetYUVPixel ()

Draw a pixel on the screen at the given coordinates.

The colour can be picked from the default colour table in chapter “8-Bit Default Palette”.

```
void SetYUVPixel (byte channel, word x, word y, byte colour);
```

Value	Size	Description
channel	byte	Channel # to be configured, can be from 0 to 3
x	word	x coordinate of the pixel
y	word	y coordinate of the pixel
colour	byte	YUV colour value picked from default palette

Example: Draw a green pixel at the coordinates on channel 0.

```
P42Display.SetYUVPixel ( CH0, 157, 079, 0x98 );
```

PrintChar ()

Print a character of the default character set, stored in SPI Flash, on the screen at the given coordinates. The character is always an 8x8 pixel area, even if the right most columns do not contain any positive pixels.

The default character set is described in chapter “Program FLASH with character bitmap”.

The colour can be picked from the default colour table in chapter “8-Bit Default Palette”.

```
void PrintChar (byte channel, char Letter, word x, word y, byte colour);
```

Value	Size	Description
channel	byte	Channel # to be configured, can be from 0 to 3
Letter	char	ASCII code of the character to print on screen
x	word	x coordinate of the top left corner of the character
y	word	y coordinate of the top left corner of the character
colour	byte	YUV colour value picked from default palette

Example: Draw a dark purple hashtag at the coordinates on channel 0.

```
P42Display.PrintChar ( CH0, '#', 0, 40, 0x23);
```

PrintString ()

Print a character string of the default character set, stored in SPI Flash, on the screen at the given coordinates. The characters are always an 8x8 pixel area (fixed width font), even if the right most columns do not contain any positive pixels.

The default character set is described in chapter “Program FLASH with character bitmap”.

The colour can be picked from the default colour table in chapter “8-Bit Default Palette”.

```
void PrintString (byte channel, char* Text, word x, word y, byte colour);
```

Value	Size	Description
channel	byte	Channel # to be configured, can be from 0 to 3
Text	char*	Pointer to the 1 st character of the sting to print on screen
x	word	x coordinate of the top left corner of the 1 st character
y	word	y coordinate of the top left corner of the1st character
colour	byte	YUV colour value picked from default palette

Example: Print a string at the coordinates in brown letters on channel 0.

```
P42Display.PrintChar ( CH0, 'Nasenbaer', 0, 40, 0xF4);
```

YUV Palette

Without a working RGB to YUV conversion yet, the easiest way is to pick the 8bit YUV colour value from the following default palette colour table:

8-Bit Default Palette

H\L	x0	x1	x2	x3	x4	x5	x6	x7	x8	x9	xA	xB	xC	xD	xE	xF
0x																
1x																
2x																
3x																
4x																
5x																
6x																
7x																
8x																
9x																
Ax																
Bx																
Cx																
Dx																
Ex																
Fx																

NTSC/PAL Color Conversion Tool

Unfortunately not available yet.

Video Signal Information

Timings for 640x480:

<http://tinyvga.com/>

<http://www.microvga.com/>

Mit einem FPGA einen alten Laptop Schirm ansteuern

https://drive.google.com/file/d/1KpEgE7tbPQhqqmzTtySVD6Gch_TDvQic/view

<https://hackaday.com/2015/10/15/spit-out-vga-with-non-programmable-logic-chips/>

<https://hackaday.io/project/9782-nes-zapper-video-synth-theremin/log/32271-vga-sync-generation>

VGA controller in VHDL

http://islwww.epfl.ch/pages/teaching/cours_isl/cas/VGA.pdf

No guarantee for the correctness of the websites listed here.

This is a living document. Any missing content will be added as appropriate.

Revision Control

Version	Data	Changes
1.0	10. Jan 2021	Initial Madman Chicken-scratch Manifesto