

Particle Photon 4 Channel Relay Shield Datasheet

Description

The Particle Photon Relay Shield was developed so that anyone could dive right into the IoT world. It can be used to control lights, motors, solenoids, and many other electrical items. The Blynk App can be used to create an app for easy control right on your phone. It has 4 relays on board that are directly connect to 4 independent digital I/O pins that are used to switch the relays on or off based on the state of the digital pin (HIGH or LOW). Table 1 below shows which digital pin is connected to each relay. It is also labeled on board between the 3-position screw terminal and the relay.

Relay #	Pin #
1	D4
2	D5
3	D6
4	D7

Table 1. Relay pinout.

Each relay has its own 3-position screw terminal labeled, NO, C, or NC, for Normally Open, Common, or Normally Closed respectively. Each relays contact current rating is 10 amps and switching voltage rating is 277 Vac and 24Vdc max.

Power can be supplied to the board by either the 2.1mm barrel jack connector that is found on the Arduino Uno, or the 2-position screw terminal. The recommended supply voltage is 12Vdc for the board, this 12 volts will be regulated down to 5V with a max current capacity of 1.5 amps for the voltage regulator.

A breadboard type space has been added so that additional electronics can be added to the board such as sensor or other control circuitry. The external circuits can be connected to the photon via the added female headers that are labeled with their respective pinout on the Particle Photon.

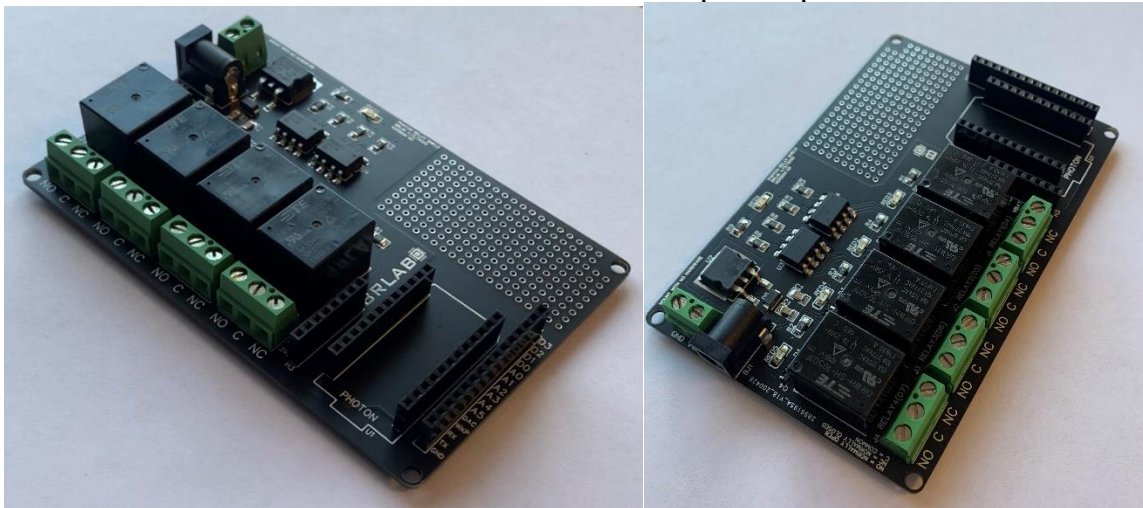

Applications

- DIY Electronics
- Home Automation
- IoT Applications
- IoT Prototyping
- Prototyping

Specifications

- Fully Assembled
- Input Voltage: Recommend 12Vdc
- Current Rating 1.5A max
- Barrel Jack or Screw Terminal Power Supply Input Connections
- 4 Channel Relay Control (isolated optocoupler control, protects the Photon)
- 0.1" Grid (for adding other electronic components such as sensors, etc.)
- Sleek Black Finish
- Leadfree HASL Surface Finish

Dimensional Specifications

Dimensions are in inches.

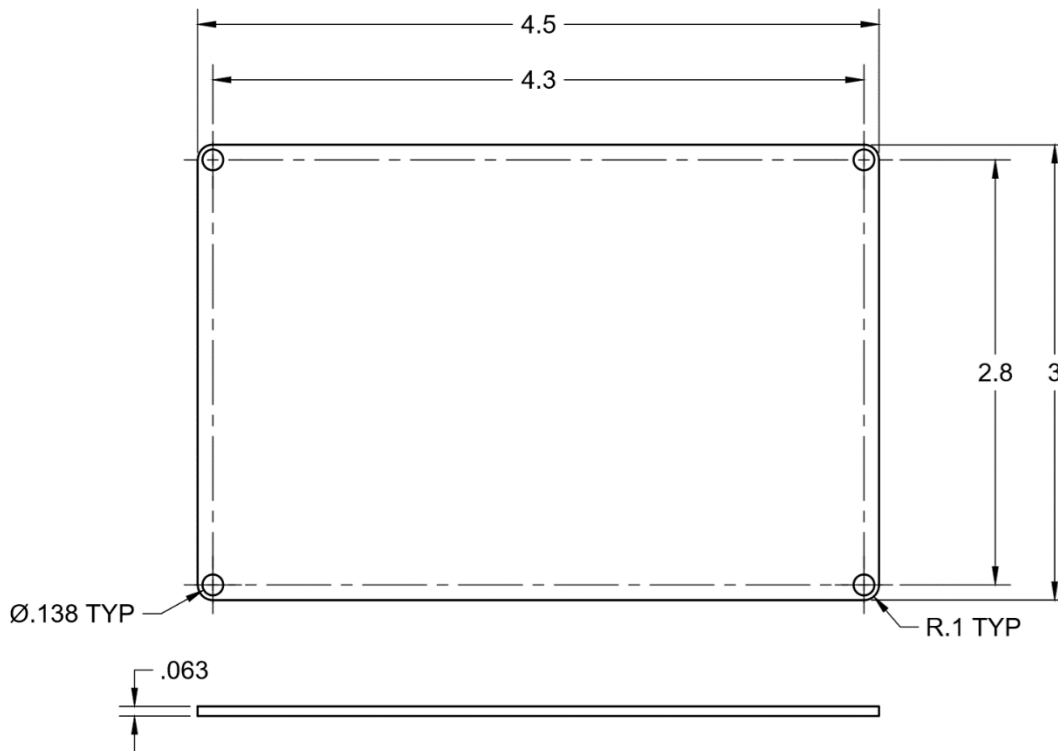

Board Layout

TOP SIDE

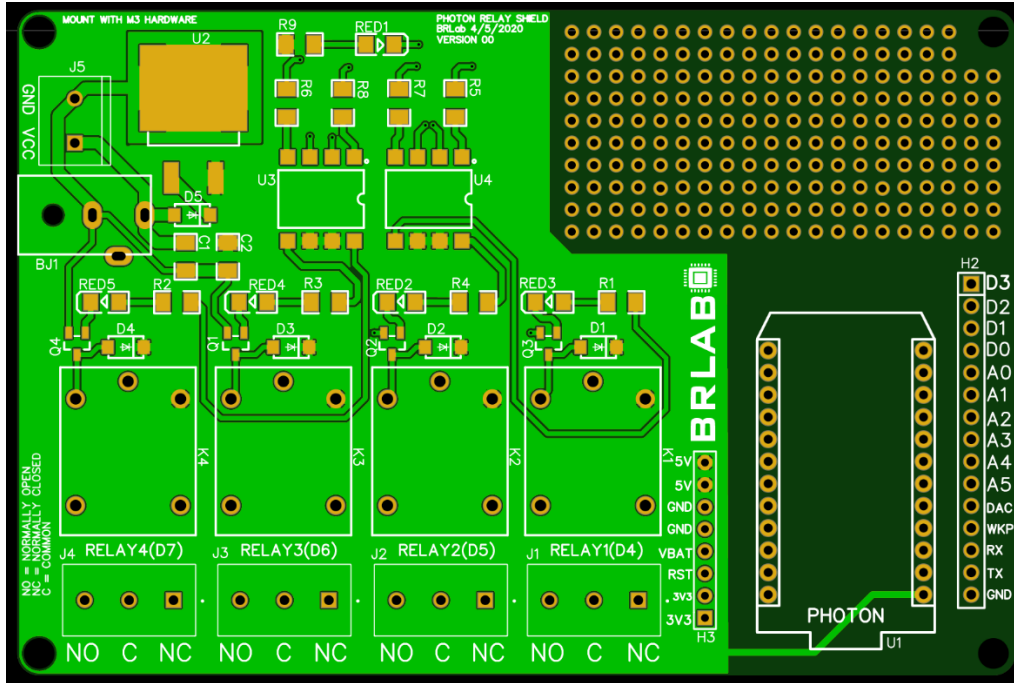

BOTTOM SIDE

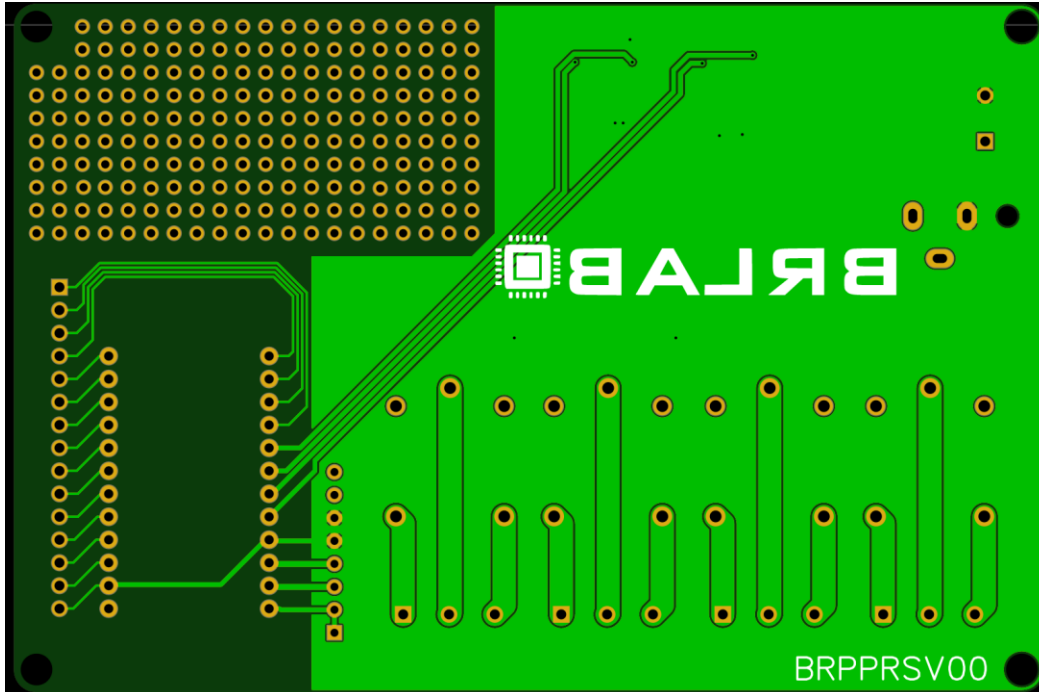

Schematic

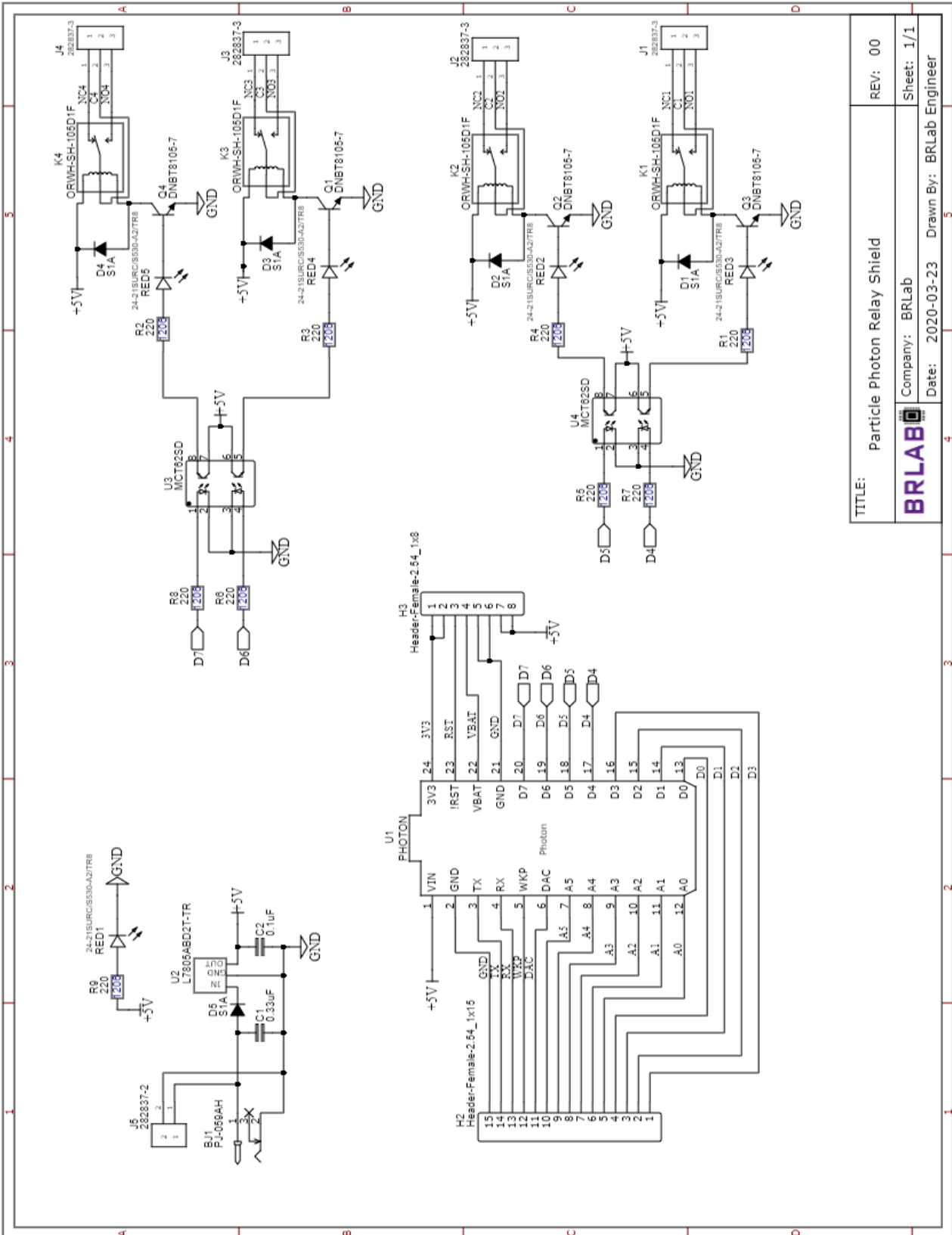

TITLE: Particle Photon Relay Shield	REV: 00
Company: BRLab	Sheet: 1/1
Date: 2020-03-23	Drawn By: BRLab Engineer

Source Code

Source code can be found here:

<https://github.com/brlabelectronics/BRPPRSV00/blob/master/Source%20Code>

Revision Changes

V00 – Initial Release

V01 – Changed document name from Particle Photon Relay Shield Datasheet to Particle Photon 4 Channel Relay Shield Datasheet. Date 02/11/2021.

Contact Info

For comments or concerns feel free to send them to brlabelectronics@gmail.com.

Please be sure to follow us on Instagram @brlabelectronics.

<https://www.instagram.com/brlabelectronics/>