

50Ω Wideband 50 to 4000 MHz

Case PN: 6UDD2W6S1A2

**Features:**

- \* Frequency Range: 50 MHz to 4 GHz;
- \* Noise Figure: 0.8 dB @ 900 MHz, typical <1dB
- \* Gain: 18 dB Gain at 900MHz
- \* Output P1dB: +22 dBm CW
- \* Output IP3: +33 dBm
- \* DC Voltage: +3 to +5V
- \* Operating Current: 54 mA
- \* Stainless Steel SMA Female Connector
- \* High Quality Isola-Tera RF PCB  
(very low loss and high thermal performance)
- \* ROHS Compliant

**Product Overview:**

LNA050M4P0G is a high-linearity, low noise amplifier designed for operation from 50MHz to 4GHz in a small 15/16"x15/16"x0.59" shielded RF enclosure (PN: 6UDD2W6S1A2). At 900 MHz, the amplifier typically provides 18 dB gain, +33 dBm OIP3 at a 54 mA bias setting, and 0.8 dB noise figure. The LNA can be biased from a single supply +3V to +5V.

**Electrical Specifications:**

Item	Parameter	Condition	Electrical Specification			
			MIN	TYP	MAX	UNITS
1	Small Signal Power Gain	0.9 GHz	16.7	18.2	19.7	dB
		1.9 GHz	11.4	12.9	14.4	dB
2	Output Power at 1dB Compression	0.9 GHz	17.4	22.6		dBm
		1.9 GHz		22.7		dBm
3	Output Third Order Intercept Point	0.9 GHz	30.0	33.0		dBm
		1.9 GHz		35.0		dBm
4	Noise Figure	0.9 GHz		0.8	1.0	dB
		1.9 GHz		0.8		dB
5	Input Return Loss	0.9 GHz	13.0	16.0		dB
		1.9 GHz		17.5		dB
6	Output Return Loss	0.9 GHz	14.5	17.5		
		1.9 GHz		16.5		
7	Reverse Isolation	0.9 GHz		23.5		
		1.9 GHz		19.0		
8	Operating Voltage			5	5.25	V
9	Operating Current (Quiescent)		28	46	54	mA

Test Conditions: V=5V, I = 46mA

**Applications:**

- \* Repeaters/DAS
- \* Mobile Infrastructure
- \* LTE/WCDMA/CDMA/GSM
- \* General Purpose Wireless
- \* SDR & Ham Radio
- \* Test Instrumentation

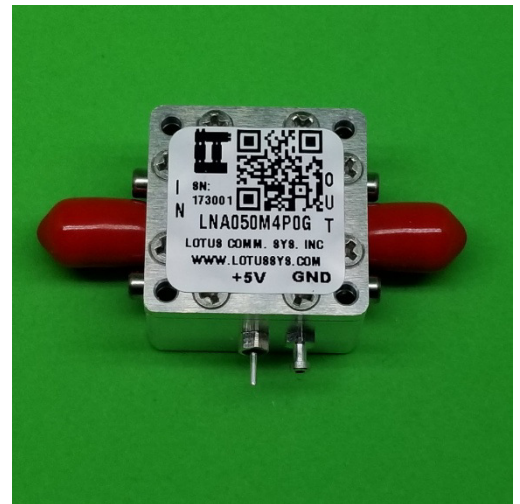

**Coaxial**  
**Low Noise Amplifier (LNA)**

**LNA050M4P0G**

**Absolute Maximum Ratings**

Item	Parameter	Rating	UNITS
1	Max Device Current	100	mA
2	Max Device Voltage	5.5	V
3	Max RF input Power	25	dBm
4	Max Dissipated Power	330	mW
5	Operating Temp.	-40 to +85	°C
6	Max Storage Temp.	-65 to +150	°C

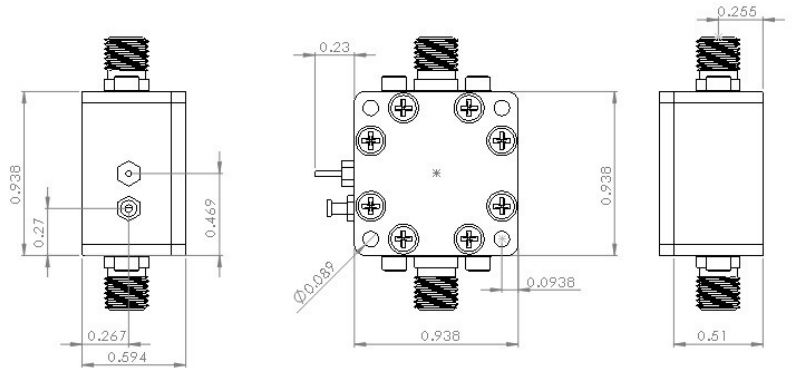

**S-Parameters**

**Outline Drawing (inch)**

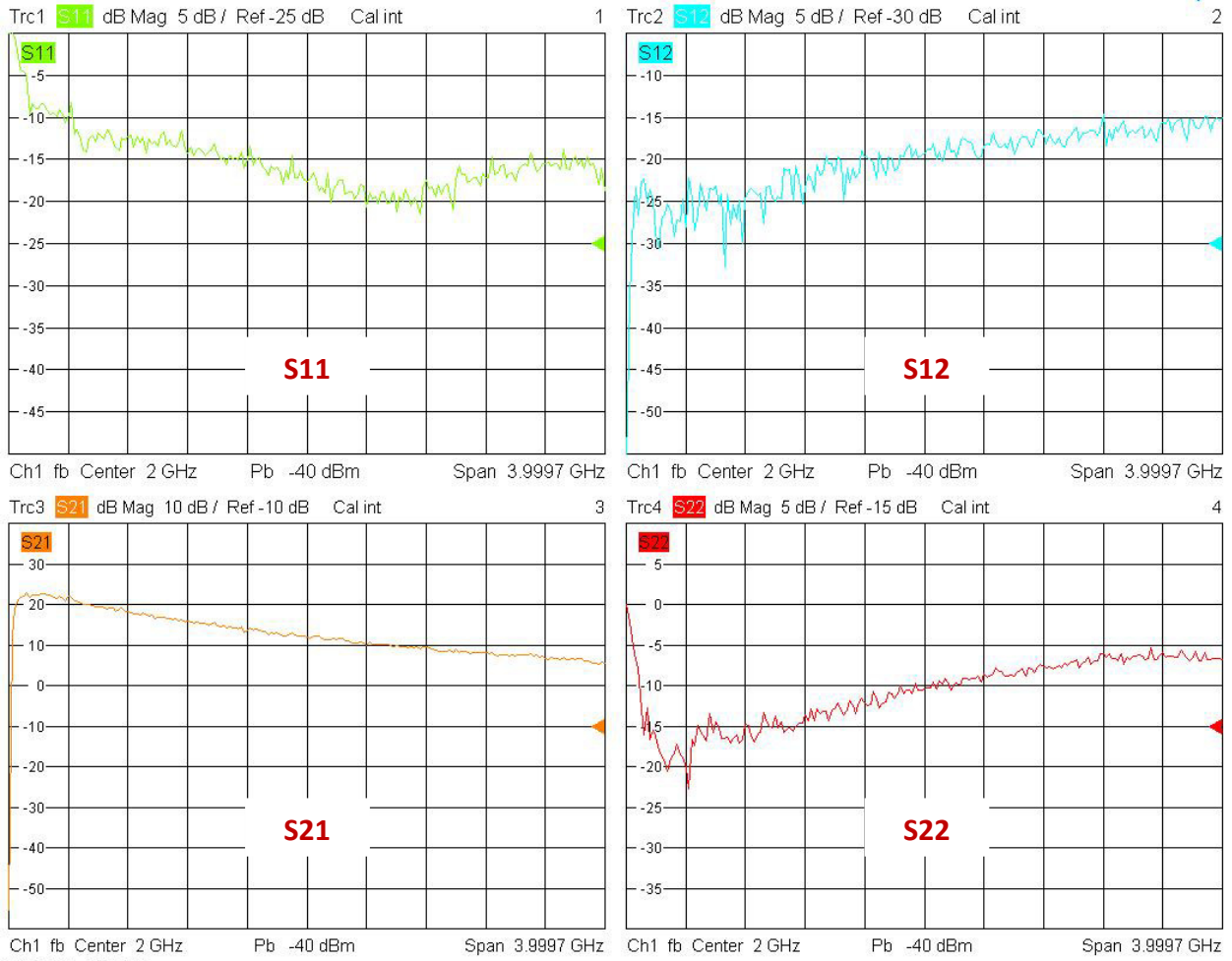

**Lotus Communication Systems, Inc.**

[www.lotussys.com](http://www.lotussys.com) 588 Boston Post Rd, Suite 200, Weston, MA 02493 (888) 236-8588 sales@lotussys.com

Rev. A LNA050M4P0G