

16 + 4 Channel Controller for Light Show with Remote Control

HomLiCon RCL164R

Application:

- Managing dynamic illuminated advertising signs, spectacular light walls, podiums, etc.
- Managing groups of lamps 120V/60Hz or 230V/50Hz - 16 channels
- Managing groups of LEDs and LED strips - 4 channels

Specifications:

Number of active channels:	9 – 20
Number of channels 120/230V:	16
Maximum output current per channel:	0.5A
Maximum output power per channel:	60W(120V) or 110W(230V)
Maximum total output current:	8A
Number of levels for each channel:	100/120
Number of channels 12-24V:	4
Supply voltage:	5 – 30V DC (by an ext. PSU)
Maximum output current per channel:	2A
Maximum total output current:	8A
Supply voltage:	110 – 130V/60Hz or 200 – 240V/50Hz
Ambient temperature:	5 – 40°C
Dimensions RCL164R:	100 x 105 x 30 mm
Dimensions Remote:	85 x 40 x 7 mm

Main features:

RCL164R is intended primarily for management of advertising signs. The number of the channels used can be adjusted from 9 to 20. When the number of active channels is up to 16 channels, the channels 17-20 automatically go into running lights mode with possible application as illuminated arrow signs, dynamic light figures and others.

For each possible number of active channels (9 to 20) can be used up to 16 lighting effects divided into two groups:

- 8 effects with smooth change of light
- 8 effects with ON/OFF control

Each of the 16 effects can be deactivated, thereby selecting only the necessary effects.

Each of the programs (effects) has three phases:

- Filling (channels are turned on in particular order)
- Retention (channels remain switched on from 0 to 7 seconds)
- Turning off (channels are turned off in particular order)

All settings can be performed by remote control from a distance up to 8 meters which can make it easier to choose the right settings, especially with bigger light objects.

Settings options for all effects:

- Number of active channels: **9 – 20**
- Backlight - light level of the channels that are turned off
- Level of external illumination for ON / STANDBY of the controller through phototransistor

Settings options for individual effect:

- Speed of channel switching
- Number of repetitions of effect **1 – 8**
- Retention time **0 – 7** seconds

Warning:

The device works with HIGH VOLTAGE !

Touching any of the elements of the device when plugged in can be life threatening.

Outputs do NOT have protection from short circuit, overload or reverse voltage.

Improper connection will lead to a damaged controller.

LED must be connected by a series resistor limiting the current to nominal (in LED strips embedded).

The controller (channels 1-16) can control lamps for 120V or 230V that allow dimming :

- Incandescent lamps
- Halogen lamps
- Dimmable LED lamps

Using lamps that do not allow dimming may damage the lamp and controller.

Wiring diagram:

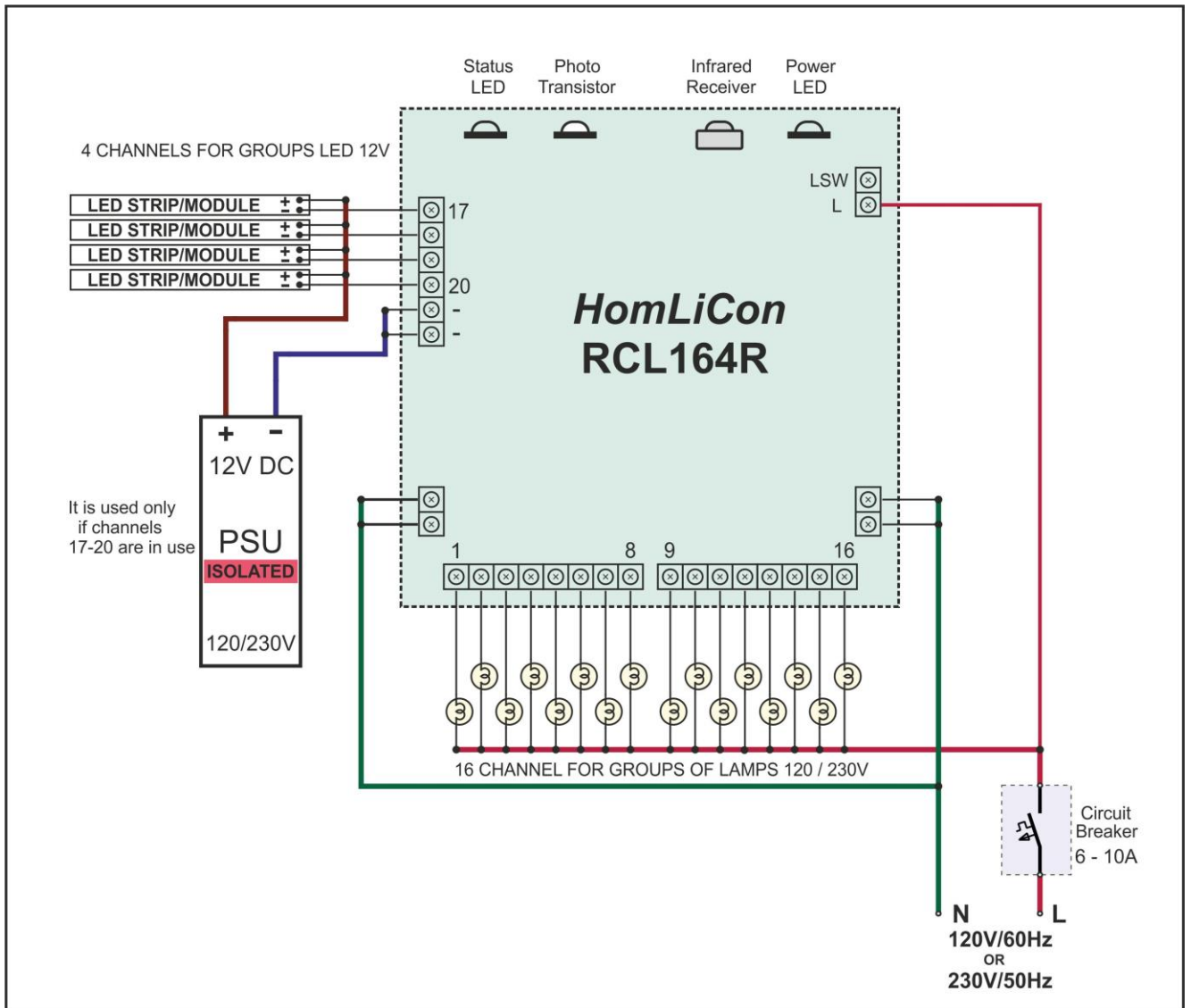



Settings and operation:

All settings are performed by the included remote control. It is possible to use another remote control with NEC protocol.



The settings are divided into seven groups as the main group is the choice of the number of active channels and the rest can be changed only when necessary. The access to each group is possible with combination of 2 buttons to avoid accidental changes. It is possible to test the adjustments for the current group without being saved into the memory and change the existing settings.

Settings are made by pressing and releasing the buttons listed in the following order:

MENU, 1 – Setting the number of the active channels. After submission of this sequence the active channels turn on and the last channel turns on/off every 0.5 seconds. By buttons **+** and **-** you can set the number of active channels (the last one always flashing).

To save the settings of this group and restart use , to reboot without changing the settings press .

MENU, 2 – Settings for the group of eight programs (effects) with gradual change of light (PWM). After submission of this sequence, Effect 1 is visualized.

Button  switches to the next effect (up to 8), and button  - switches to previous (back to 1). The settings apply to the current effect and can be different for each effect, except the level of backlight.

To deactivate the current effect and visualize the next one (previous, if next doesn't exist) press **C**.

Activation of a particular deactivated effect is not possible. Instead, the entire group of 8 effects is activated (effect 1 is visualized) by pressing button **TEST**. To indicate that all 8 effects in the group are deactivated, channels 2 and 4 will turn on.. This is possible only when in another group there is at least one active effect.

Adjusting the level of the backlight can be made by pressing buttons **6** increase and **9** decrease. The settings of the level apply to all 16 effects at all times and affect the perception and the speed of the programs (effects) with a smooth change of the light. It is recommended to set up the initial configuration. The ability to change the settings for each effect is used for visualization and selection of the appropriate level. After each change of the backlight, the current effect starts from the beginning.

The rate for each effect is different and can be adjusted using **+** and **-** buttons.

The number of repetition for the current effect can be adjusted by pressing the buttons **4** and **7**, and can be from 1 to 8, where for visualization are used channels 1-8. Pressing the button once serves only for visualization. Pressing it again serves for regulation. After the visualization the current effects start from the beginning.

The retention time for which channels remain on after the filling phase is adjusted by the buttons **5** and **8**, and may be from 0 to 7 seconds. For visualization channels 1 - 8 are used. Pressing the button once serves only for visualization. Pressing it again serves for regulation. After the visualization the current effects start from the beginning.

To save the settings of this group and restart use , to reboot without changing the settings press .

MENU, 3 – Settings of the group with eight programs (effects) with a rapid change of light (ON / OFF). After submission of this sequence, Effect 1 is visualized.

With button **▶▶** can be switched to next effect (up to 8), and with **◀◀** - previous (to 1) The described settings apply to the current effect and are different for each effect except for the level of backlight.

To deactivate the current effect and visualize the next one (previous, if next doesn't exist) press **C**.

Activation of a particular deactivated effect is not possible. Instead, the entire group of 8 effects is activated (effect 1 is visualized) with the button **TEST**. To indicate that all 8 effects in the group are deactivated, channels 2 and 4 will turn on. This is possible only when in another group there is at least one active effect.

Adjusting the level of the backlight can be made by pressing buttons **6** increase and **9** decrease. The settings of the level apply to all 16 effects at all times and affect the perception and the speed of the programs (effects) with a smooth change of the light. It is recommended to set up the initial configuration. The ability to change the settings for each effect is used for visualization and selection of the appropriate level.

The rate for each effect is different and can be adjusted using **+** and **-** buttons.

The number of repetition for the current effect can be adjusted by pressing the buttons **4** and **7**, and can be from 1 to 8, where for visualization are used channels 1 - 8. Pressing the button once serves only for visualization. Pressing it again serves for regulation. After the visualization the current effects start from the beginning.

The retention time for which channels remain on after the filling phase is adjusted by the buttons **5** and **8**, and may be from 0 to 7 seconds. For visualization channels 1 - 8 are used. Pressing the button once serves only for visualization. Pressing it again serves for regulation. After the visualization the current effects start from the beginning.

To save the settings of this group and restart use **↶**, to reboot without changing the settings press **⏻**.

MENU, 4 – (indication - Channel 4)

Speed settings of the effects (running lights) on channels 17 - 20. The adjustment can be made by pressing the **+** and **-** buttons. This option is available only if the number of active channels is up to 16.

To save and restart use **↶**, to reboot without changing the settings press **⏻**.

MENU, 5 – (indication - channel 5)

Mode selection:

- Normal mode (effects depending on settings) - Button **▶**
- Turning on all active channels – **TEST** button

To save and restart use **↶**, to reboot without changing the settings press **⏻**.

MENU, 6 – (indication - channel 6)

Reset the user settings and return to the original (factory).

To select reset press button **0**, the indication becomes channel 6 and 8. If they are not stored in an interval of 3 seconds it is cancelled.

To save and restart use **↶**, to reboot without changing the settings press **⏻**.

MENU, 7 – (indication - channel 7)

Settings of the level for ON / STANDBY of the controller according to the external light. The adjustment of the level of 1 to 6 can be made with the + and - buttons. As an indication channels 1 - 6 are used. Level 1 – ON/OFF in high brightness (afternoon / late morning) level 5 in low light (late night / early morning). At level 6 the controller is always enabled. Channel 8 is used for indication whether the controller will be ON/OFF according to the set level and the current light conditions. Changing the brightness or the set level takes 6 second due to averaging the data in order to avoid activation from accidently directed light.

To save and restart use ↶, to reboot without changing the settings press ⏻.

In normal mode the following commands are possible:

TEST, ⏻ – ON / STANDBY

TEST, ⏮ – Current group of effects (PWM or ON / OFF) can be skipped and effect 1 is visualized from the other group.

Arrangement of the buttons on the remote control: