

Voltage divider for comparators

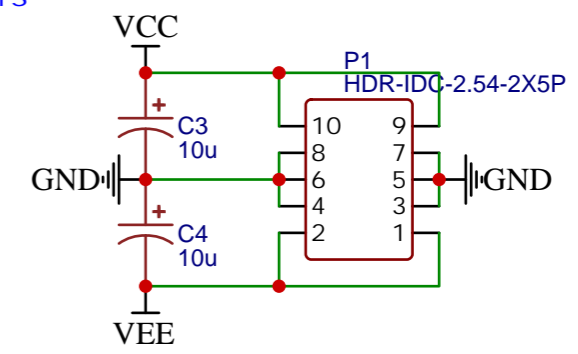

Use a voltage divider calculator to find out the values for your desired voltage out:
<https://ohmslawcalculator.com/voltage-divider-calculator>
 this can also be used to get four distinct CV values outputs for a "keyboard" kind effect.

If you dont wish to use the voltage dividers then solder together along the thick lines on the PCB...

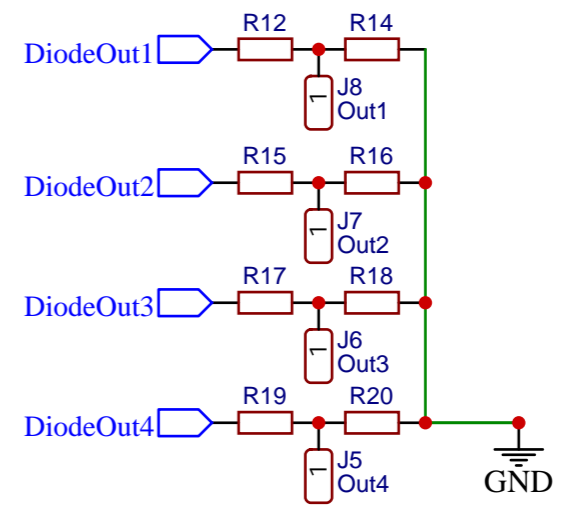

v0.9 added direct out
 v0.8 added voltage dividers on all outputs

TITLE: Touch Me Now Gate Control PCB V0.7		REV: 1.0
EasyEDA	Company: Your Company	Sheet: 1/1
	Date: 2021-02-14	Drawn By: Kristian Blå sol