

pod bay 3

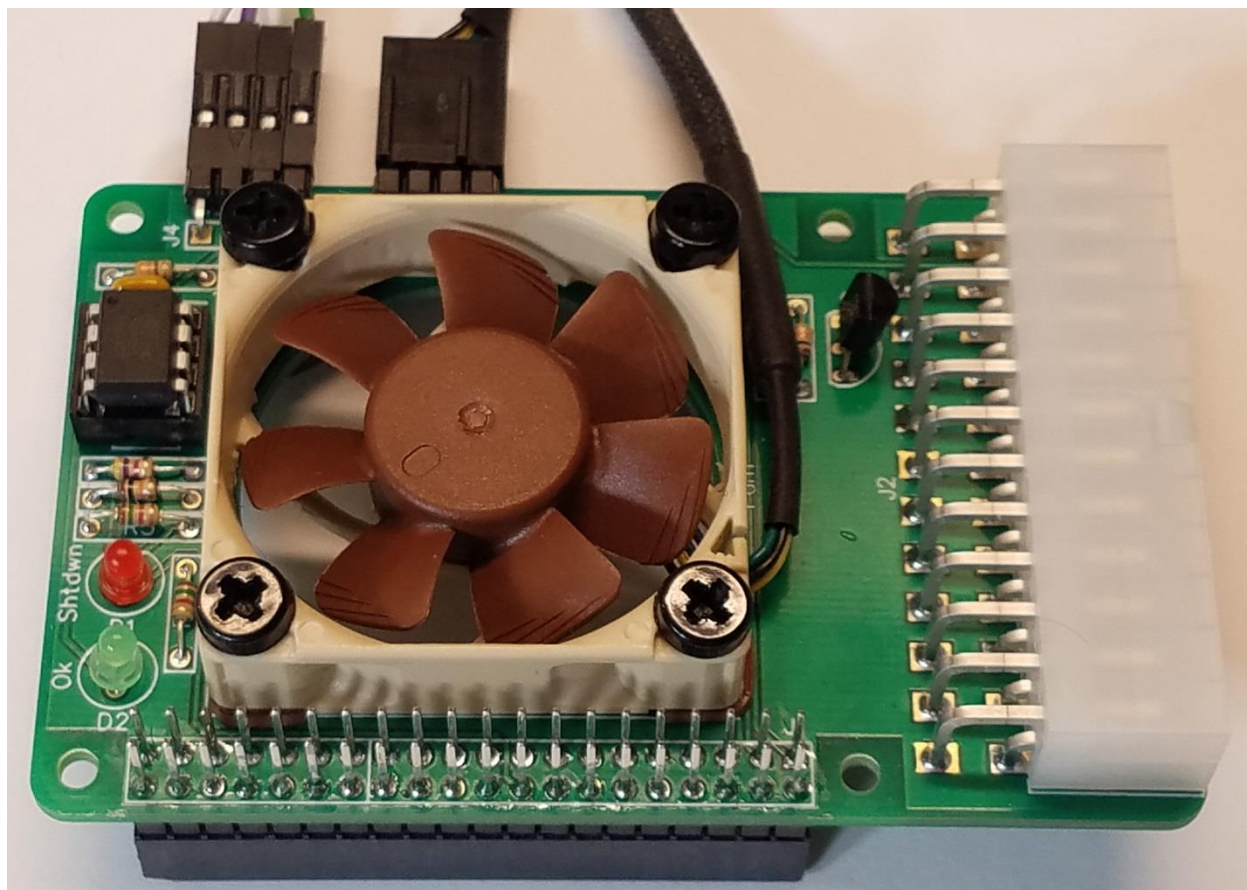

PiRyte Mini ATX PSU-Cool Revision 1.0 User Manual

PiRyte Mini ATX PSU-COOL Installation and User Guide.

July 7, 2018

Overview

Congratulations on your purchase of the PiRyte Mini ATX PSU-COOL!

Please read this entire manual before using to ensure you receive maximum benefit from this board while protecting your investment in your Raspberry Pi/PiRyte stack.

While reading this document, please refer to the graphic below on the following pages.

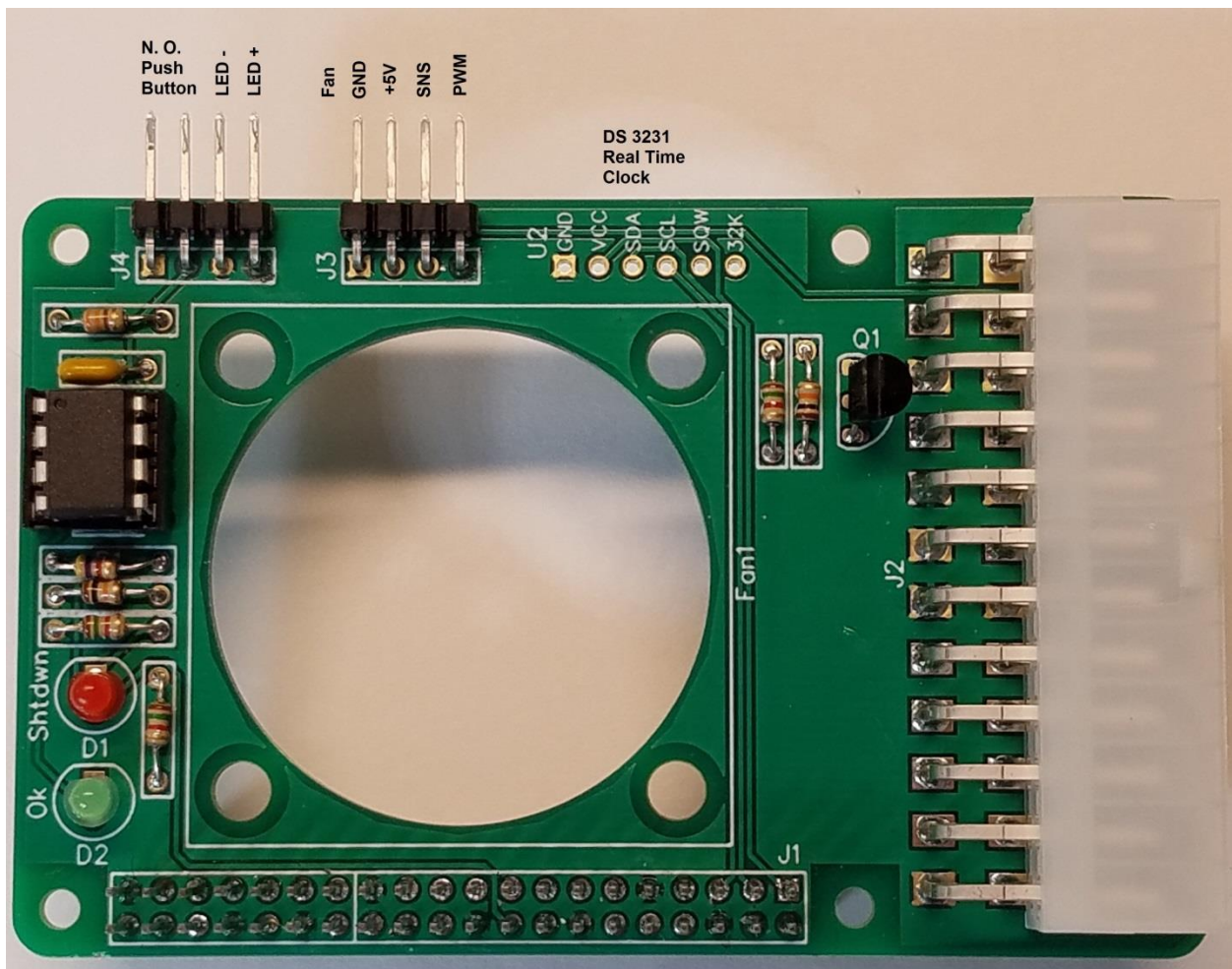

PiRyte Mini ATX PSU-COOL Installation and User Guide.

July 7, 2018

Specifications

- Uses inexpensive off the shelf ATX desktop supply. Works with 24 pin ATX connectors.
- Enables operating system to perform controlled shutdown and reboots to minimize disk file corruption.
- You can program the Mini ATX PSU-COOL so that it will automatically reboot after a power failure if it was previously turned on.
- Back powers the Raspberry Pi with dedicated 5 VDC line.
- Compatible with common 40mm X 40mm fans with 4.2mm diameter mounting holes on 32mm centers.
- PCB is 1oz copper with ENIG finish.
- Uses high quality Samtec and Molex connectors.
- Conforms to the Raspberry Pi Foundation's HAT footprint.
- 40 Pin GPIO stacking header allows use of other HAT conforming boards.
- Supports 5VDC fan for cooling the Raspberry Pi
- I2C signals brought out so you can plug in external modules such as a real time clock
- Comes as a DIY kit to keep costs low.

Installing the Mini ATX PSU-COOL

The purpose of the Mini ATX PSU-COOL is to back power your Raspberry Pi from an ATX style desktop power supply while providing cooling for the Raspberry Pi's processor chips. **Therefore, you must not plug in the Raspberry Pi to its normal 5 VDC USB power supply while the Mini ATX PSU-COOL is installed otherwise damage to your Raspberry Pi WILL occur.**

You will install the Mini ATX PSU-COOL in this order:

1. Unbox the Raspberry Pi, install its operating system per its instructions.
2. Mount the Mini ATX PSU-COOL to the Raspberry Pi.
 - a. Ensure the Raspberry Pi is not connected to its USB power.
 - b. Connect the Mini ATX PSU-COOL to the ATX power supply, power LED and switch.
 - c. Turn on power by depressing the power switch and allow the Raspberry Pi to boot up.
The Mini ATX PSU-COOL will now be waiting for the 'Boot Ok' signal from the Raspberry Pi.
3. Install the required boot script on to the Raspberry Pi and reboot the machine. When it reboots, it will then send the 'Boot Ok' signal to the Mini ATX PSU-COOL telling it to now wait for a power down request.

PiRyte Mini ATX PSU-COOL Installation and User Guide.

July 7, 2018

You will find the necessary boot script at: https://github.com/tomtibbetts/Mini-ATX-PSU/raw/master/scripts/ATX-PSU_startupsetup.sh. This script does two things:

1. Sends a signal to the Mini ATX PSU-COOL indicating that the Raspberry Pi booted up properly (turns on the 'Boot Ok' LED).
2. Monitors the 'Shutdown' signal from the Mini ATX PSU-COOL. When the 'Shutdown' signal pulses for 0.5 seconds, the script will then initiate a reboot of the Raspberry Pi. If the signal persists longer than 0.6 seconds the script initiates a shutdown of the Raspberry Pi.

Please note that this script requires the use of GPIO 4 (pin 16, 'Boot Ok') and GPIO 5 (pin 18, 'Shutdown'). These pins were selected because they do not conflict with special use pins such as I2C, SPI or UART pins.

To install the script, follow these instructions: (recommended to have Mini ATX PSU-COOL mounted on the Pi. Otherwise the Pi may automatically shutdown after reboot)

1. `sudo wget https://github.com/tomtibbetts/Mini-ATX-PSU/raw/master/scripts/ATX-PSU_startupsetup.sh`
2. `sudo bash ATX-PSU_startupsetup.sh`
3. `sudo rm ATX-PSU_startupsetup.sh`
4. `sudo reboot`

ATX Molex Connector

The Mini ATX PSU-COOL is designed to work with 24 pin Molex Mini fit Jr. power supply connectors.

Mating the Mini ATX PSU-COOL to the Raspberry Pi

Your Mini ATX PSU-COOL conforms mostly to the Raspberry Pi HAT specification. The exceptions are that it is a bit oversized to accommodate the Molex connector and that it does not have the configuration EEPROM. Additionally, the stacking header requires that the spacing between boards to be a bit more than what is specified.

Initially, the stacking connector J1 will fit into mating connectors on the Pi very tightly so care must be taken to not damage boards or bend connector pins by using too much force if you wish to separate the boards later on. Therefore, it is recommended to use a rocking approach for both stacking and separating boards. For example, when stacking, gently seat the top board on top of the bottom board ensuring that J1 is properly aligned. Pick one end of the board and gently apply pressure. Release pressure, then move down along the connector and apply pressure again and so on back and forth until

PiRyte Mini ATX PSU-COOL Installation and User Guide.

July 7, 2018

the two boards are properly seated. Use the same principals when separating the boards; do a little bit at a time working back and forth along the connectors.

It is recommended to use the threaded standoffs that come with the board to ensure a tight mechanical fit. If this board is the first to be stacked on top of the Raspberry Pi, then use the extra nuts as spacers shown in the image below. This will ensure proper spacing between the Raspberry Pi and the Mini ATX PSU-COOL. You do not need the extra spacing for additional boards mounted on top of the first board.

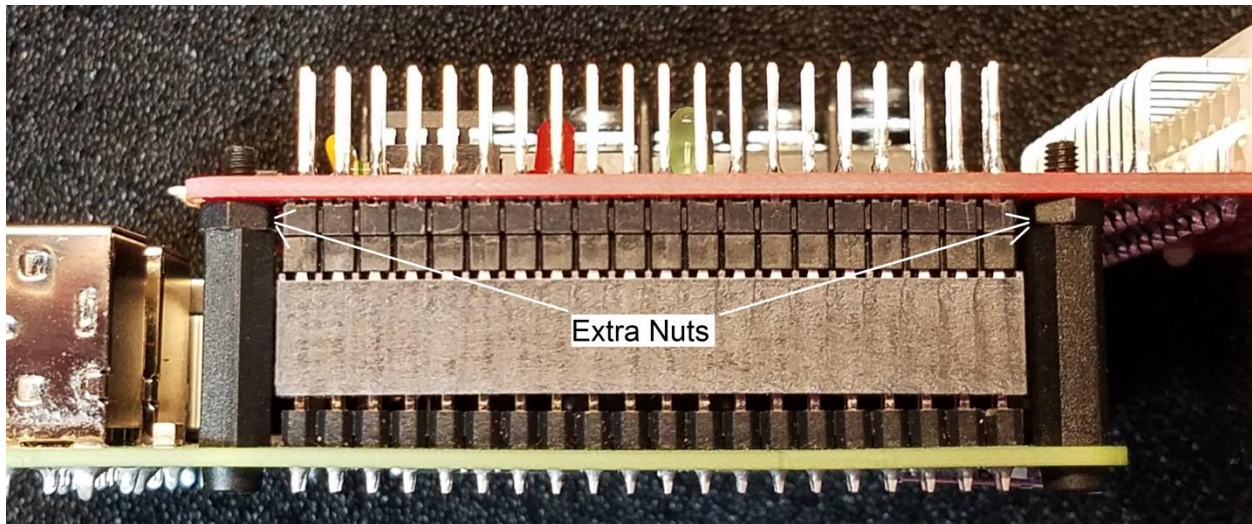

Operating Modes

Program Mode:

By default, the Mini ATX PSU-COOL is programmed to not automatically reboot after a power failure if it was turned on prior to the power failure. If you wish to have the Mini ATX PSU-COOL automatically reboot once power is restored, then please refer to the programming instructions in the next section.

Turning on the ATX Power Supply:

Turning on/plugging in the ATX power supply will supply a trickle voltage to the microcontroller on the Mini ATX PSU-COOL. If the Mini ATX PSU-COOL has been programmed to automatically reboot in the event that power has been interrupted, then it will do so now, otherwise it will wait for you to push the normally open power switch connected to the Mini ATX PSU-COOL.

Power up:

Depressing the power switch when the Raspberry Pi is turned off will initiate the power up sequence. The power indicator LED pulsates slowly until the 'Boot Ok' signal is received from the Raspberry Pi at which time it will go steady on.

PiRyte Mini ATX PSU-COOL Installation and User Guide.

July 7, 2018

Reboot:

When the Raspberry Pi is running, depressing the power switch for over a half a second will dim the power indicator LED. If you release the switch at this point a short pulse is sent to the Raspberry Pi to initiate a reboot and the power LED will pulsate slowly until the machine has rebooted at which time it will go steady on.

Shutdown:

When the Raspberry Pi is running, depressing the power switch for over a half a second will dim the power indicator LED. If you hold, then release the power switch for longer than two seconds a long pulse is sent to the Raspberry Pi to initiate a controlled shutdown. The power indicator LED will pulsate slowly until the machine is safe to have power removed at which time the power indicator LED will pulsate quickly for ten seconds before the Mini ATX PSU-COOL turns off the Raspberry Pi.

Hard Shutdown:

When the Raspberry Pi is running, depressing the power switch for over a half a second will dim the power indicator LED. If you hold the power switch for ten seconds the Mini ATX PSU-COOL will turn off power to the Raspberry Pi. This feature is beneficial in the case that the Raspberry Pi has crashed and is not able to be turned off in a controlled manner.

Command line or Application Forced Shutdown:

If the user issues a command to shut down the Raspberry Pi, 'sudo poweroff', the Mini ATX PSU-COOL will detect this by listening in on the boot ok line. As the Pi shuts itself down, the boot ok line will go low and the Mini ATX PSU-COOL power led will start to pulsate. If the Pi does not reboot itself, i.e. 'sudo reboot' within twenty seconds, then the Mini ATX PSU-COOL will turn off the desktop power supply. If, within twenty seconds the Pi reboots, then the power led will go steady on and the Mini ATX PSU-COOL will operate as before.

Programming the Mini ATX PSU-COOL to Perform Auto-reboot

1. Start with a fully assembled Mini ATX PSU-COOL that is mounted on your Raspberry Pi. Make sure that the ATX desktop power supply is connected and turn off. If the power supply was recently on, you may need to wait a few seconds for its power capacitors to discharge.
2. While pushing and holding the power button connected to J4, turn on the ATX desktop power supply. The power indicator LED of the Mini ATX PSU-COOL will pulse once if it's programmed to auto-reboot or pulse twice if it's programmed to auto-reboot. Release the power button. You are now able to program the Mini ATX PSU-COOL.
3. If you do nothing more, then the Mini ATX PSU-COOL will rapidly blink the power indicator three times in a row and reset the unit taking it out of programming mode. After five seconds you can turn it in on as you would normally.

PiRyte Mini ATX PSU-COOL Installation and User Guide.

July 7, 2018

4. If, within five seconds, you momentarily push the power button it will toggle its state then pulse the power indicator LED to reflect its new state, once for no auto-reboot, twice for auto-reboot.
5. If you're done then go to step three. If you wish to toggle the Mini ATX PSU-COOL's state again, then go to step four.

Assembling the PiRyte Mini ATX PSU-COOL

We assume that you already have some experience assembling kits and soldering parts. If not, we strongly encourage you to practice soldering skills on high quality perf boards first. There are several Youtube videos on how to solder.

Regardless of your soldering skills, here are some things to consider:

1. Please use a soldering iron of sufficient wattage. A 40 watt pencil tip soldering iron will work. A hot iron will minimize cold solder joints and solder bridging between pins.
2. Double and triple check your solder joints that you are not creating solder bridges between pins, especially on the power connectors. Also, ensure that solder joints have a 'fillet'. See below:



The following order of assembly is recommended:

1. Test fit the stacking header, J1 on the Raspberry Pi 40 pin header before soldering to ensure proper fit. Now, solder in J1. Make sure that it is "upside down" i.e. with the female portion of the socket under the board so that it can mate with other PiRyte boards and the Raspberry Pi. For best results, make sure the socket is snug against the board and perpendicular to the board.
2. Solder C1.
3. Solder R1 – 4.7K resistor.
4. Solder R3, R4, R5 – 1.5K resistor.
5. Solder R2, R6 – 10K resistor.

PiRyte Mini ATX PSU-COOL Installation and User Guide.

July 7, 2018

6. Solder R7 – 330 ohm resistor.
7. Solder socket for U1. Insert U1 into socket observing proper I.C. alignment. Pin one of the I.C. is marked by a dimple on the I.C. Please refer to the photo on page 2.
8. Solder LEDs D1 (red), D2 (green) observing properly alignment of LEDs. The short leg of the LED will go into the square hole and the flat side of the LED should line up with the flat side of the outline on the board.
9. Solder Q1 transistor observing proper alignment of transistor to match the outline on the board
10. Solder J2, J3 and J4.

Note: Resistors R1 and R2 form a voltage divider to level shift the 5 volt signal from the ATTiny processor on the Mini ATX PSU-COOL to an acceptable voltage level for the Raspberry Pi. Please double check that the correct resistor value is in the correct place.

Mounting the Fan (optional):

The PCB is compatible with common fans such as the Noctua NF-A4X10 5V. Connector J3 supports PWM (4 pin) and non-PWM (3 pin) plugs. Because only the GND and +5 V pins are used, the fan will turn on and run constantly when the ATX power supply turns on. This allows the usage of less expensive fans if desired. The ground pin on connector J3 corresponds to pin 1 on the Noctua plug.

The fan footprint on this board requires that fans be 40mm on each side and that the mounting holes 32mm on center. You can mount the fan using M4 sized screws. Nylon screws are recommended to prevent unintended electrical shorts. With 10mm tall fans you can get by with M4 X 15mm screws or larger.

The Noctua fans show air flow direction on the casing. You will have better cooling by directing the air to flow down on the CPU chips.

Please refer to the fan manufacturers documentation for further details and questions.

Installing a DS3231 Real Time Clock (optional):

DS3231 real time clock modules are inexpensive and readily available from a variety of sources on the Internet. In fact it is much more economical to buy one of these modules and install it on the Mini ATX PSU-COOL than it would have been to integrate the DS3231 chip onto the circuit board. Therefore, the PCB was designed to bring out the necessary I2C and power lines to run these common RTC modules.

When you examine the PCB, you will notice an area for a connector labeled 'U2'. This is where you will install the DS3231 module as shown in the graphic below. Please note the orientation of the module. These four pins of the module, GND, VCC, SDA, and SCL need to align with those pins on the PCB:

PiRyte Mini ATX PSU-COOL Installation and User Guide.

July 7, 2018

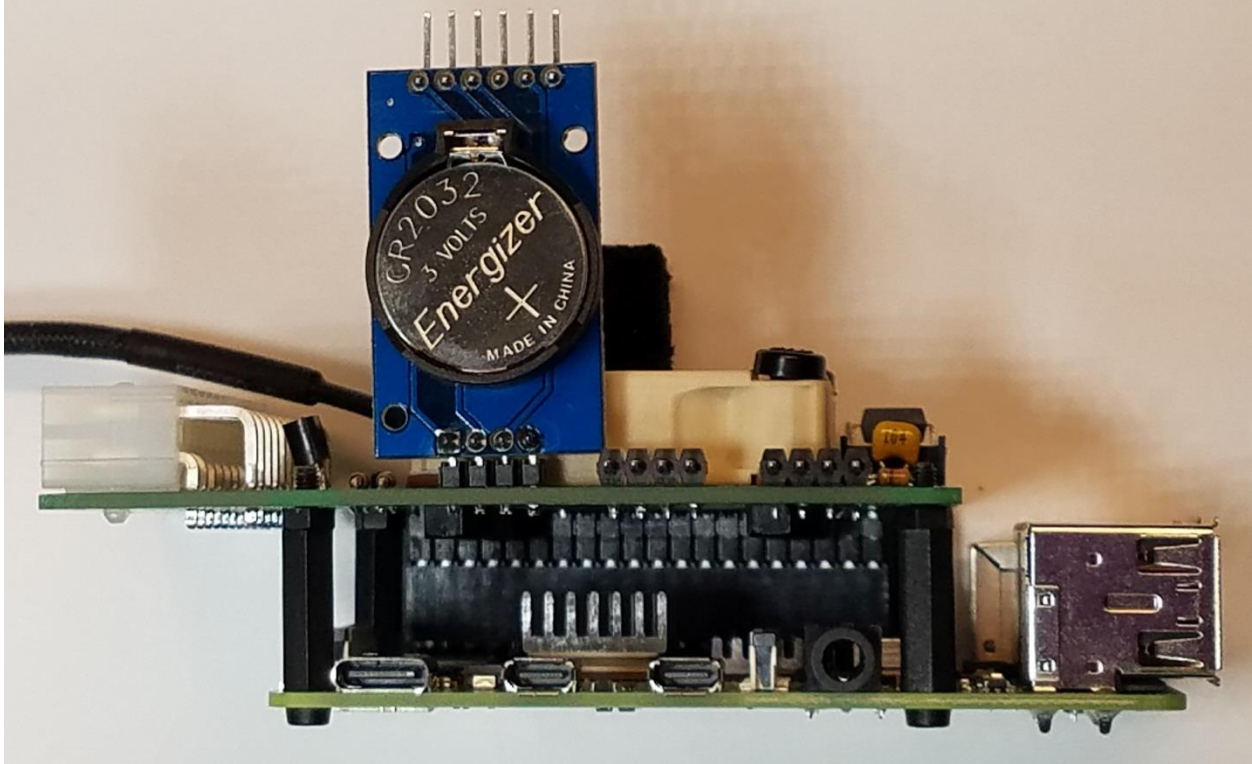

These modules seemed to have been designed to work natively on Arduinos. So, since we're using a Raspberry Pi, we will need to modify the module a bit.

First off, if you wish to use non-rechargeable coin battery (the holder is on the reverse side of the module) you will need to remove the resistor as shown below in the red box next to the SCL line.

Next, since the Raspberry Pi already provides the necessary pull up resistors for I2C, we will need to remove those as well from the module. This is indicated on the graphic below to the lower left corner of the DS3231 module.

PiRyte Mini ATX PSU-COOL Installation and User Guide.

July 7, 2018

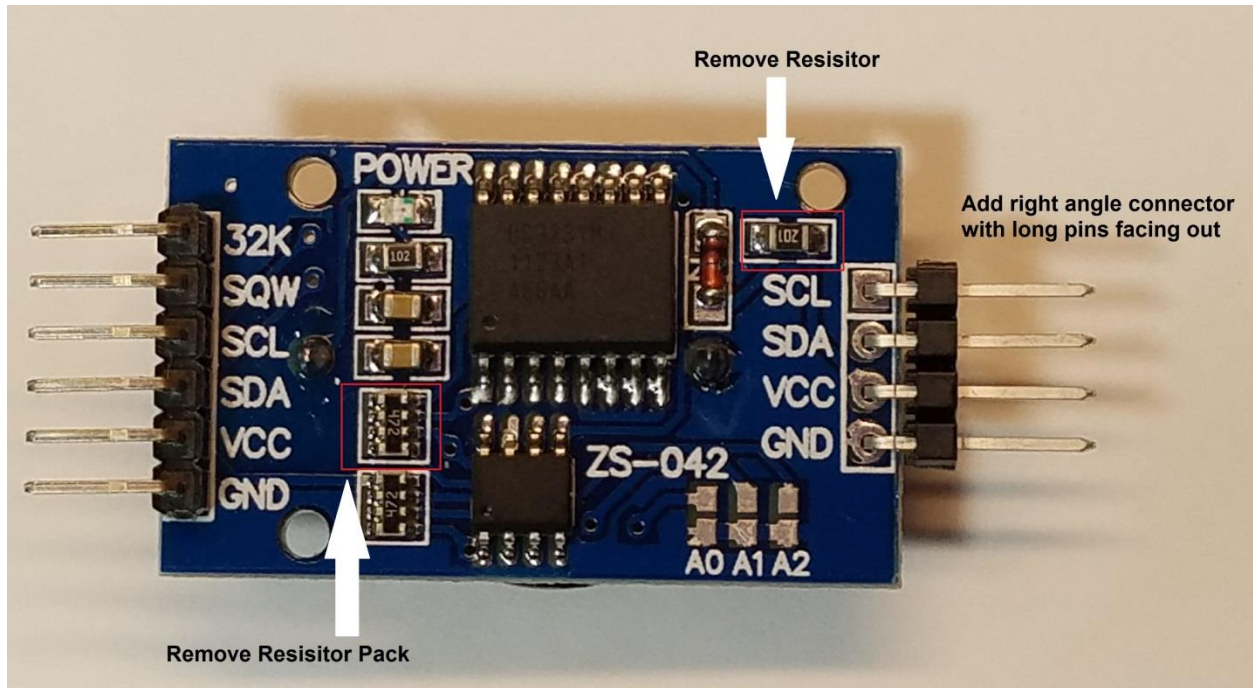

Programming the Pi to run the DS3231 should be relatively easy with the following steps:

1. Ensure you are connected to the internet. This will make sure your Pi has the most current time
2. Open up a command line window.
3. Sudo nano /boot/config.txt
4. Add the following line to the bottom of the file, "dtoverlay=i2c-rtc,ds3231
5. Control 'X' and 'Y' to exit and save your changes
6. Sudo nano /lib/udev/hwclock-set
7. Look for the line starting with, "if [-e /run/systemd/system...
8. Comment that line and the following such that it now looks like:





```
# if[-e /run/systemd/system];then  
#exit 0  
#fi
```
9. Control 'X' and 'Y' to exit and save your changes
10. Sudo reboot to program the ds3231 with the most current time.
11. You can test the clock by powering off the Pi and disconnecting it from the internet for several minutes. When you power up the Pi again, it should have the correct time.

In the event the above steps do not work, you may need to do some detective work for trouble shooting. There are plenty of examples on the Internet for interfacing this module with a Raspberry Pi.

PiRyte Mini ATX PSU-COOL Installation and User Guide.

July 7, 2018

Bill of Materials:

Quantity	RefDes	Name	Value	
1	C1	CAP .1uf	100nf	
1	D1	Shutdown	Red	
1	D2	Boot Ok	Green	
2	J3, J4	1 X 4 Header	1 X 4 Header	
1	Q1	2N4401 Kinked	2N4401	
1	R1	RES GENERIC .125W	4.7K	
2	R2, R6	RES GENERIC .125W	10K	
3	R3, R4, R5	RES GENERIC .125W	1.5K	
1	R7	RES GENERIC .125W	330 Ohm	
1	U1	ATTINY85_PDIP	ATtiny85-20PU	
1			8 pin socket	
1	J1	Raspi-40	40 Pin Stacking Header	
1	J2	Molex 39-30-1241	Molex 39-30-1241	

PiRyte Mini ATX PSU-COOL Installation and User Guide.

July 7, 2018

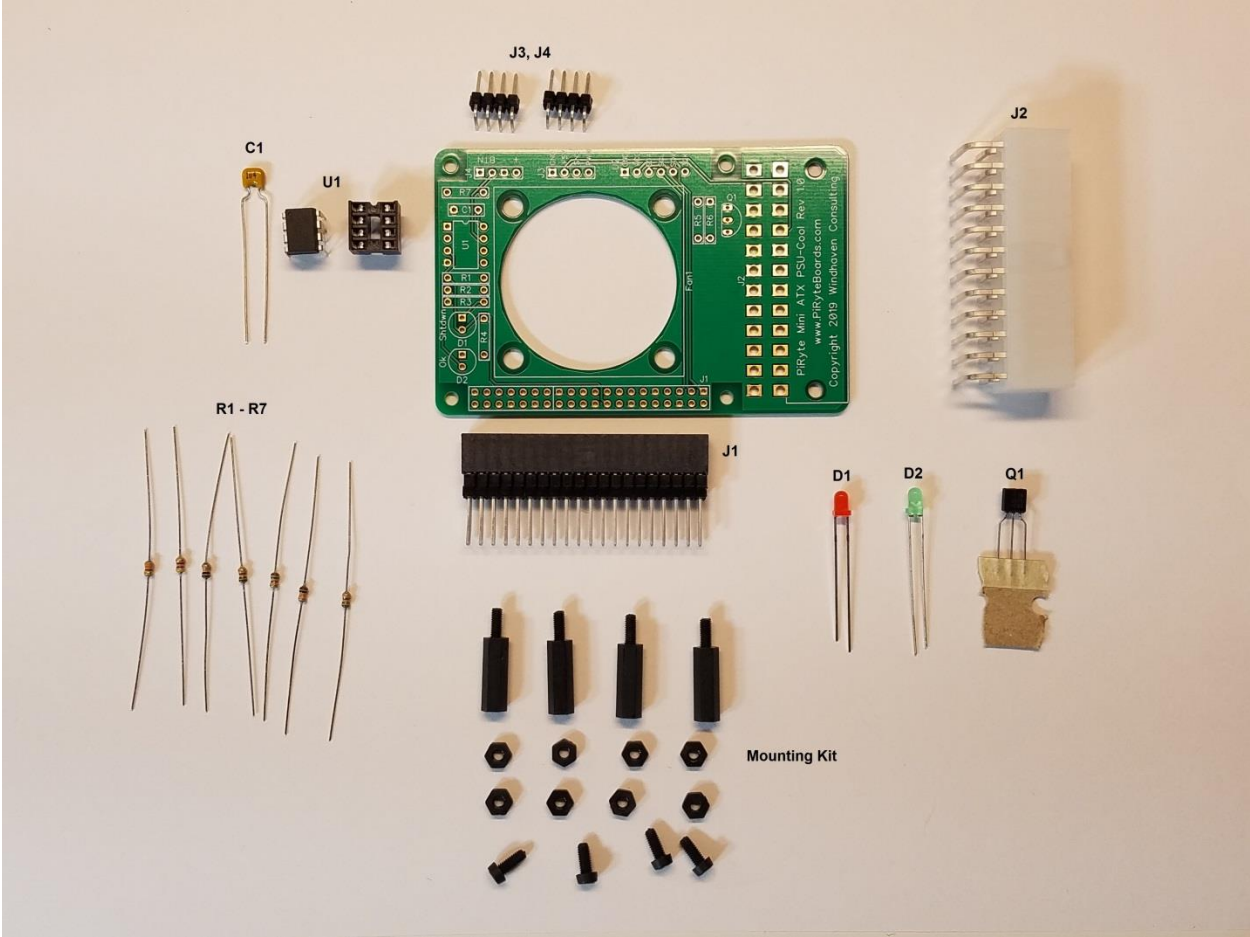

Figure 1: Parts Reference

PiRyte Mini ATX PSU-COOL Installation and User Guide.

July 7, 2018

Warranty

Unassembled kits are warranted for the parts only as home assembly cannot be controlled. However, if you do find yourself with a non-working board and have exhausted all attempts to fix the issue, then the board may be exchanged for a new kit at a discounted price.

Product that has failed for non-warranted reasons may be exchanged for new or equivalent functionality at a discounted price. Please email us using the "Contact Us" page at <http://www.piryteboards.com/> for more details.

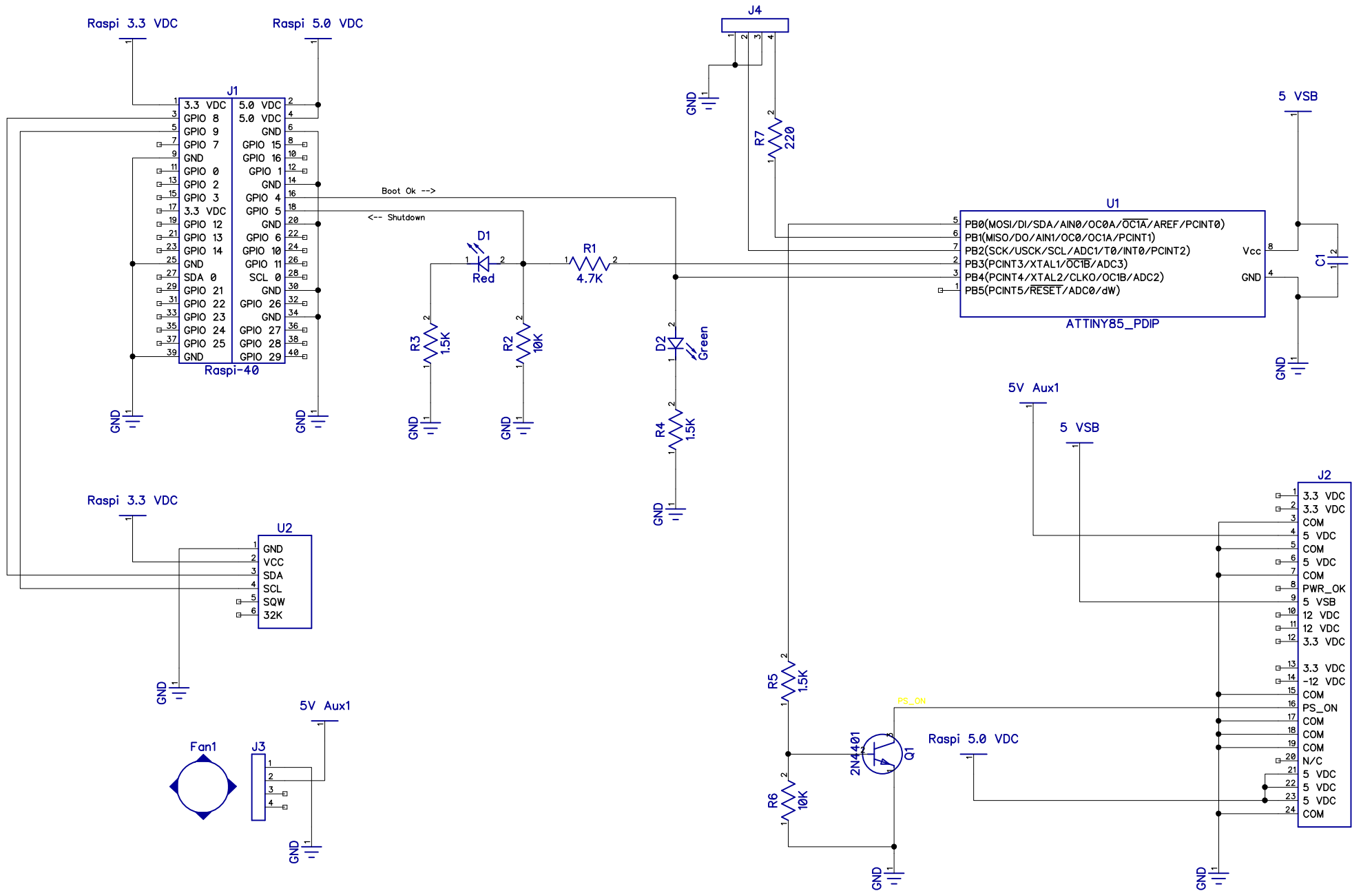

PiRyte ATX PSU-Cool		
Size	Number	Rev
	Copyright 2019	1.0
	Windhaven Consulting, Inc.	
Date: 11/10/2019	Thomas Tibbetts	
Filename	Sheet 1	

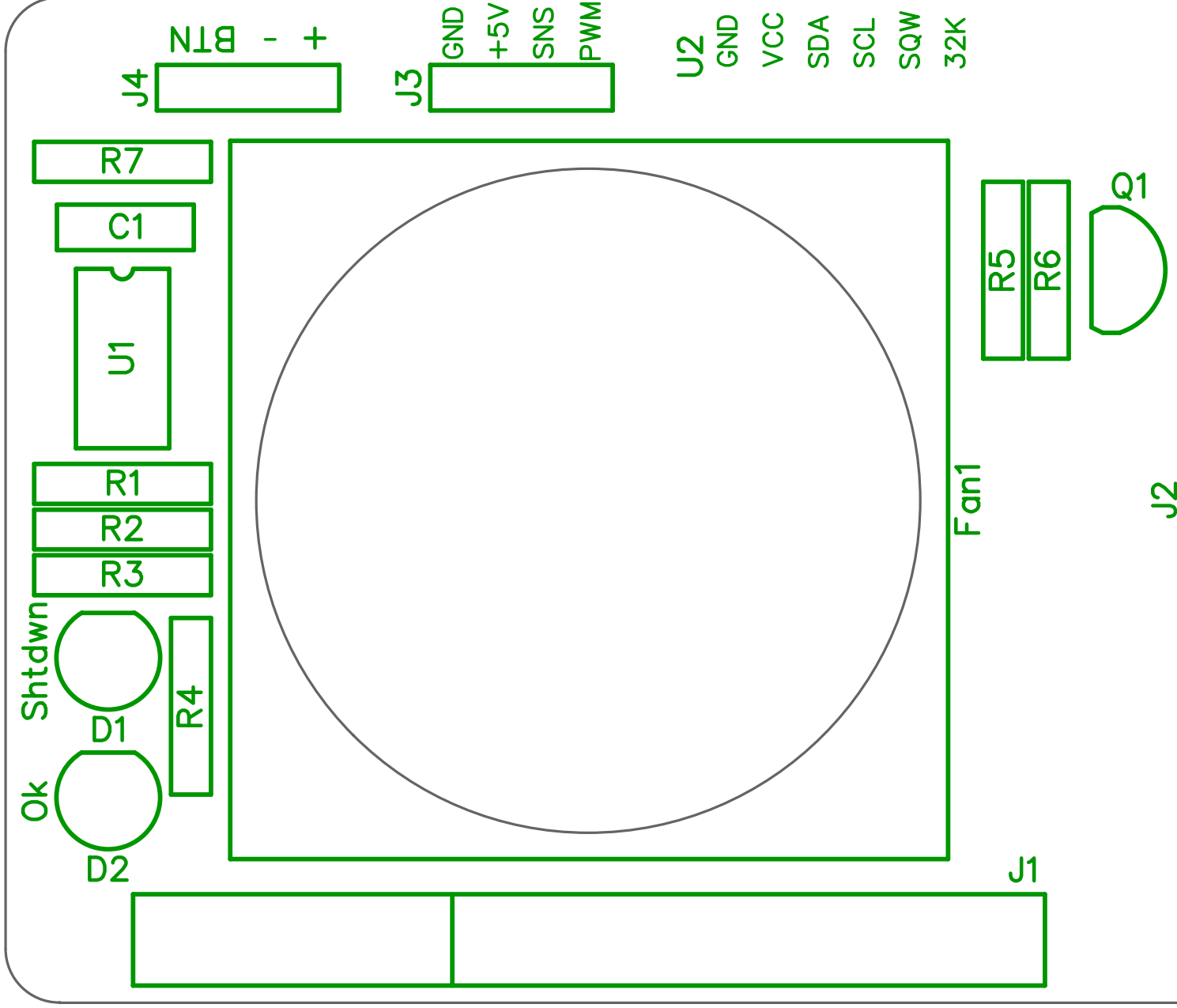

PiRyte Mini ATX PSU-Cool Rev 1.0
www.PiRyteBoards.com
 Copyright 2019 Windhaven Consulting