

# Teensy 3.2 Breakout (Revision A)

## Standard Included Parts

- **(1×)** Teensy 3.2 Breakout (Revision A) bare printed circuit board
- **(3×)** 40-pin (1 row × 40 pins) through-hole male header
- **(1×)** 14-pin (2 rows × 7 pins) surface-mount male header
- **(2×)** #6-32 × 3/16" stainless steel pan-head machine screw
- **(1×)** gold-plated pogo pin (spring-loaded connector)
  - Mill-Max Manufacturing **0906-1-15-20-75-14-11-0**
  - Digi-Key part number **ED8181-ND**
- **(1×)** 32.768 kHz tuning fork crystal
  - Citizen **CFS-20632768DZFB**
  - Digi-Key part number **300-1002-ND**

## Optionally Included Parts

- **(1×)** 150 µF tantalum capacitor
  - Kemet **T495D157K010ATE100**
  - Digi-Key part number **399-8506-1-ND**
- **(1×)** surface-mount DIP switch
  - Copal Electronics **CHS-01TB**
  - Digi-Key part number **563-1004-1-ND**

## Detailed Specs

- **Grid Spacing** — 0.1 in (2.54 mm)
- **Board Dimensions** — 2.4 in (60.96 mm) × 0.9 in (22.86 mm)
- **Board Surface Area** — 2.16 in<sup>2</sup> (13.94 cm<sup>2</sup>)
- **Number of Breakout Pins** — 48 pins (2 rows × 24 pins)
- **Number of Mounting Holes** — 2 holes
- **Mounting Hole Distance** — 2.0 in (50.8 mm)
- **Mounting Hole Diameter** — 0.15 in (3.81 mm)
- **Mounting Hole Pad Diameter** — 0.27 in (6.858 mm)

## Recommended Tools

- Soldering iron
- Solder
- Flux
- Breadboard
- Diagonal cutters
- Needle-nose pliers
- Masking tape
- Prying tool

## Assembly Instructions

1. Gather the necessary tools, setup a clean workspace, and warm up your soldering iron. Before proceeding with assembly of the Teensy Breakout, decide if you want to use the **real time clock** (by adding a 32.768 kHz crystal), enable **USB host mode** (by adding a 150  $\mu$ F capacitor), or require **external power for USB device mode** (by cutting a trace to separate VIN from VUSB). Since these changes are made on the bottom side of the Teensy, **you must make them before continuing!** For more information about these modifications, please see the Teensy documentation. If you're installing a DIP switch on the bottom of the breakout board, **you must cut the VIN-VUSB trace!** When you're ready to proceed, position the Teensy so its bottom side is facing up (*Drawing 1*).
2. Cut a 5-pin length of through-hole header and position it on the underside of the Teensy along the shorter edge so that it interfaces with the A14 (or RESET on the Teensy 3.0), PROGRAM, GND, 3.3V, and VBAT pins (*Drawing 2*). Flip the board over and solder the header in place. Using an empty breadboard to position the components (here, and for many subsequent soldering steps) can ensure that the headers are installed perfectly perpendicular to the board. You can use an extra pin header strip placed sideways under the opposite end of the board to make sure it sits flat.
3. Position the provided 14-pin (2 rows  $\times$  7 pins) surface-mount header on the underside of the Teensy. The bent pins should sit directly on the rectangular pads, and the straight end of the pins should stick up (*Drawing 3*). Secure the header in place (tape placed along the edge works well) making sure the pins are centered over all the pads. Solder all the pins in place and remove the tape.
4. Cut another piece of 5-pin header and remove just the metal pin from the 2nd position using a pair of needle-nose pliers, leaving a blank position in the header. Fit this modified header (now with 4 pins and one blank space) on the underside of the Teensy so it occupies the A11, A10, AREF, and VUSB pins (*Drawing 4*). Solder it in place, using your breadboard as a guide to ensure proper alignment.

5. Fit the straight pin ends of the attached headers through the matching holes in the Teensy Breakout board (*Drawing 5*). The distance between the boards will be determined by the surface-mount header since it sits higher than the through-hole headers. As a result, there will be a small gap between the single-row headers and the breakout board, which is normal. Holding the boards so they're parallel to each other, trim the extending pins (all 23 of them) with your diagonal cutters so they're flush with the board, then separate the two boards.
6. Cut two 14-pin lengths of through-hole header, and fit them along the two longer edges on the underside of the Teensy (*Drawing 6*). Solder them, ideally continuing to use your breadboard as a temporary holder to ensure proper alignment.
7. Once again, align the Teensy with the breakout board (*Drawing 7*) and trim the extending pins (28 of them) with diagonal cutters so they're nearly flush with the underside of the board. As before, make sure the gaps on each side are even. Once all the remaining pins are trimmed, separate the two boards.
8. **If you're NOT using a switch (to select the power source) then SKIP THIS STEP!**  
You should have already cut the VIN-VUSB trace on the Teensy. Place the Teensy Breakout board face-down in front of you. Place the surface mount DIP switch onto the box marked VUSB (*Drawing 8*). The orientation of the part doesn't matter since the switch will either open or close the connection and its ON position is marked on the housing. Securely solder both leads onto the board. When the switch is in the ON position the Teensy will receive power via the USB connection, otherwise it will need to be hooked up to an external power source.
9. **If you're using a Teensy 3.0 (instead of a Teensy 3.1 or 3.2) then SKIP THIS STEP!**  
Place the Teensy Breakout board face-up on your work surface. Locate the two holes marked with POGO which are outlined with circles. Insert the gold pogo pin into the appropriate hole for your particular Teensy version. Use the hole marked with T3.2 if you're using a Teensy 3.2 or the hole marked with T3.1 if you're using a Teensy 3.1. The thicker spring-loaded end should be facing away from the board, and the pin's thinner tail should sit in the hole (*Drawing 9*). Place the board on the edge of your table so that the area with the pogo pin is hanging over the edge. Tape the board in place and apply solder at the base of the pogo pin.

10. Connect the two boards (*Drawing 10*) and position the assembly so the underside of the Teensy Breakout board is exposed. Secure the boards in place with two pieces of tape, one placed on each end, being careful to make sure the gaps remain even on both sides and the two boards remain parallel. The pogo pin (if installed) may provide some resistance, but the boards should be pushed together as closely as possible. Solder all 51 through-hole pins connecting the Teensy to the Teensy Breakout board. Retouch the pogo pin solder connection on this side as well.
11. Cut two 24-pin lengths of through-hole header, and fit them along the two long edges of the Teensy Breakout board (*Drawing 11*). These exposed header pins will allow the entire assembly to interface with a standard breadboard. As before, the use of a breadboard to hold these pins in place while soldering them is highly recommended. Solder all 48 pins along both edges.
12. Being careful to apply light alternating pressure on opposite ends, remove the entire assembly from the breadboard. Applying too much pressure on one side can result in rapid release and rotation, causing the pins on the opposite side to bend or break off. Use of a slender metal tool (like a small screwdriver) to pry the assembly away from the breadboard, loosening it carefully from both ends, can greatly reduce the risk of bending or breaking any pins. Inspect the finished assembly to make sure everything is aligned correctly and that all pin connections are securely soldered (*Drawing 12*). Connect the Teensy to power with a USB cable and make sure it's working well.

## **Congratulations, you're finished!**

- **If you enjoy using this board** please consider leaving me a positive review on Tindie!
- **If you have any concerns or problems** please contact me at the email address below.

## **Contact Information**

- **Name** — Daniel Gilbert
- **Website** — tall-dog.com
- **Email** — loglow@gmail.com

1

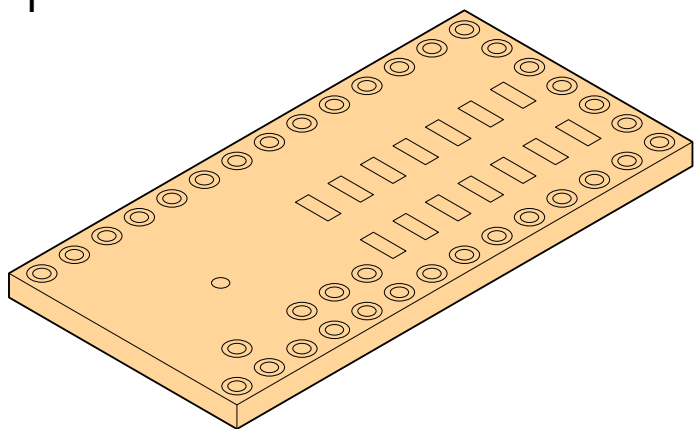

2

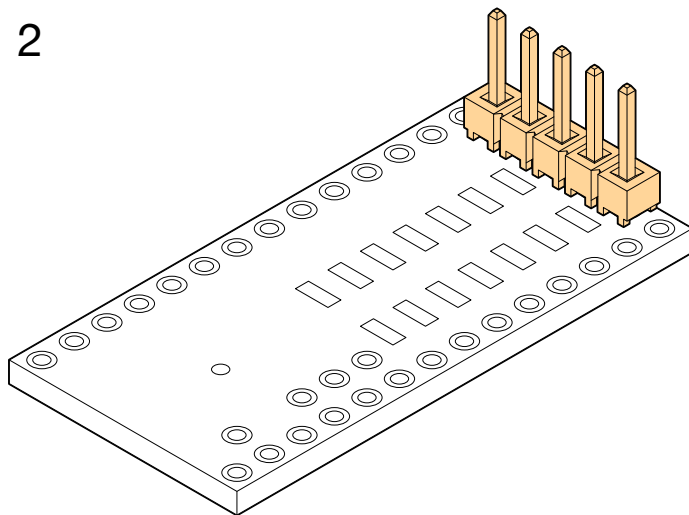

3

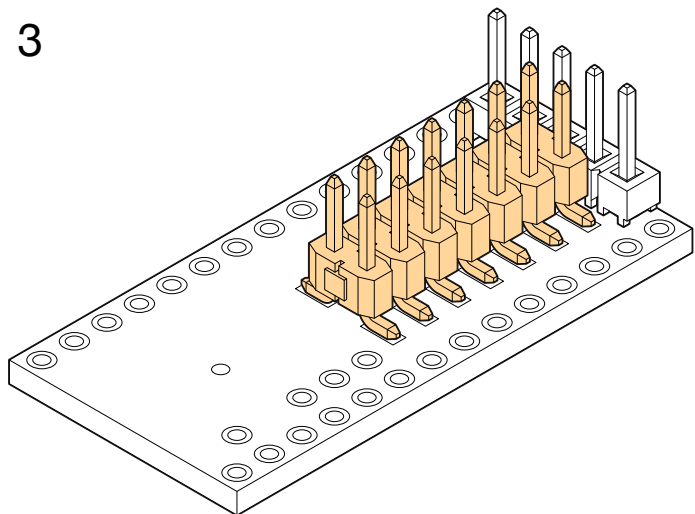

4

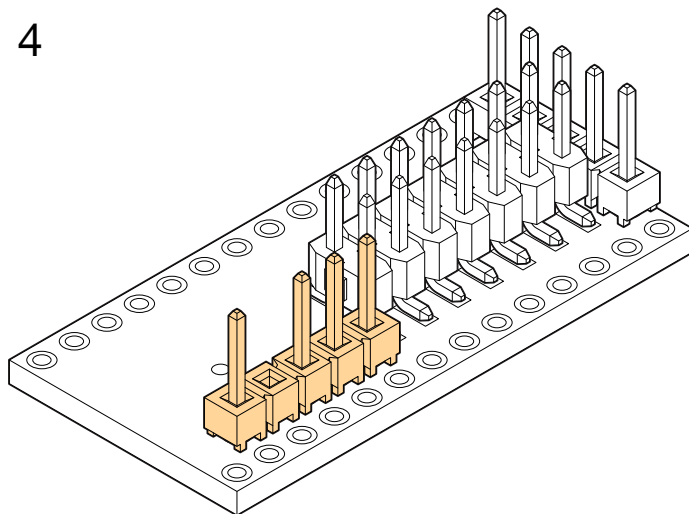

5

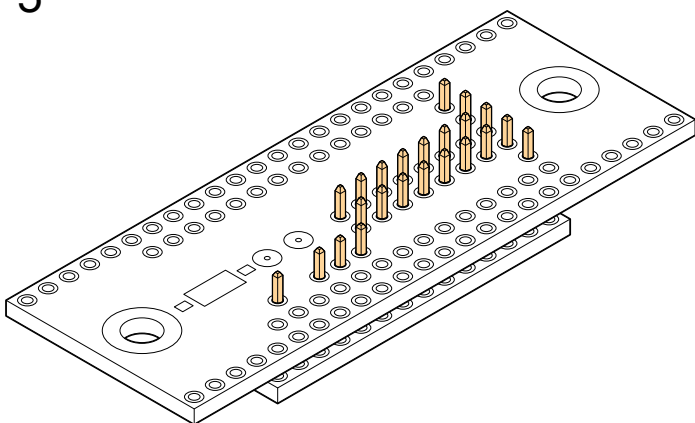

6

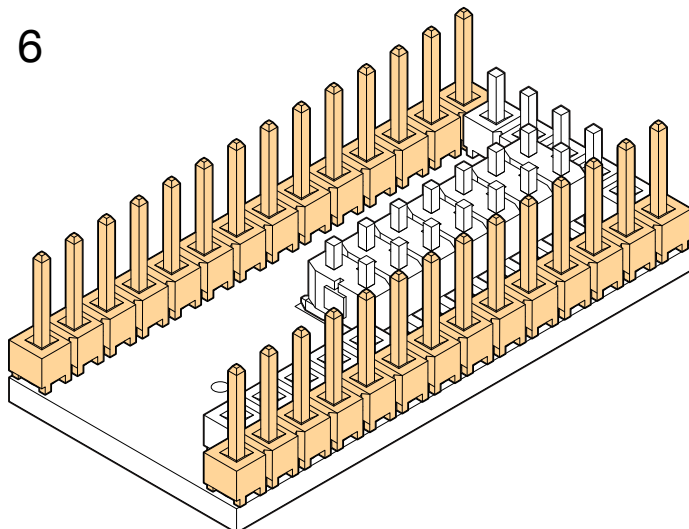

7

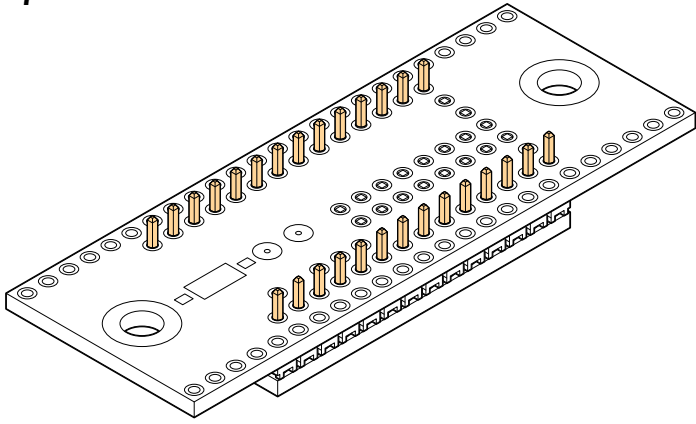

8

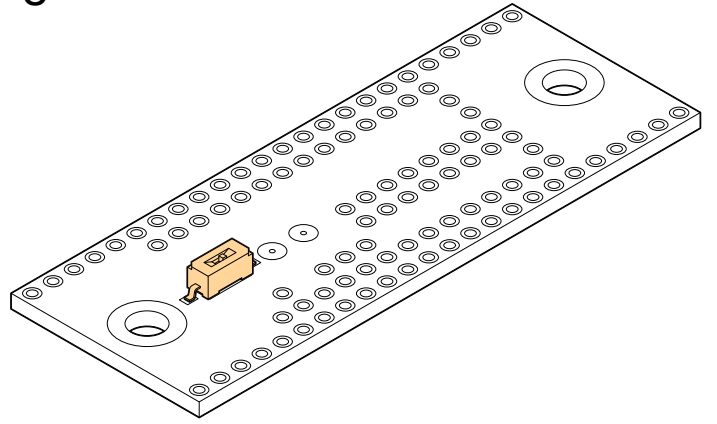

9

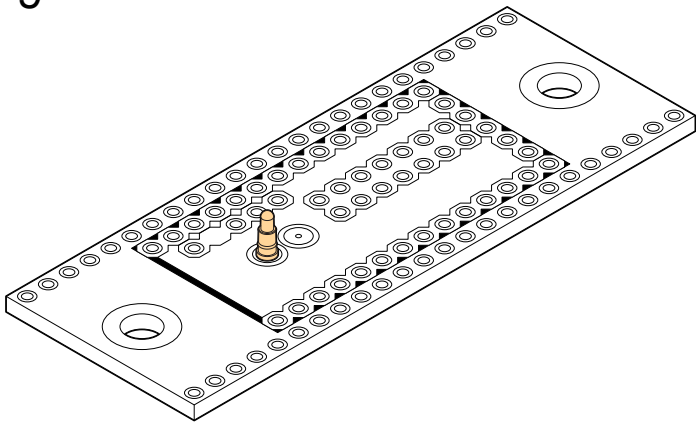

10

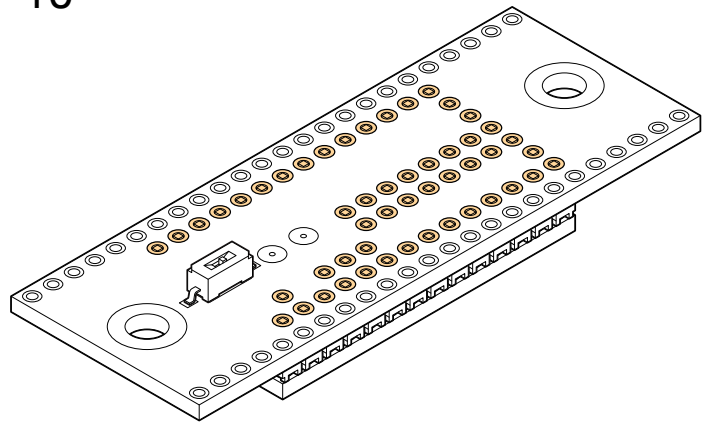

11

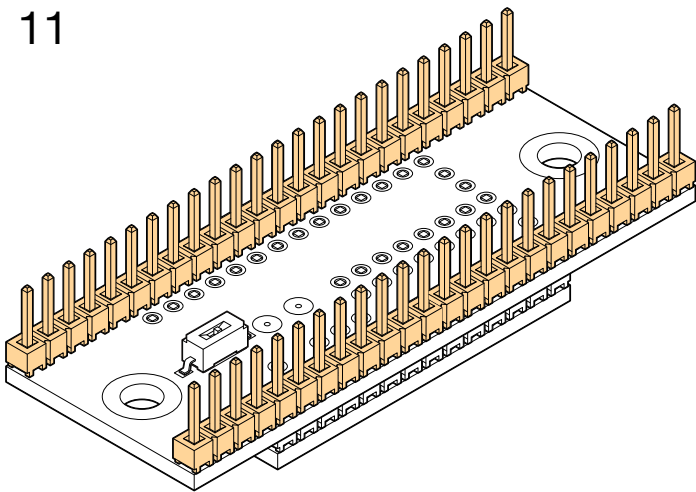

12

