



BLE 5.1 nRF52811 Module MS50SFB Specification



The MS50SFB3 is a compact and small size Bluetooth 5.1 module with ultra-low power consumption; Bluetooth 5.1 module is AOA & AOD supported. The module has the large number of GPIOs and excellent RF performance

Features

Frequency: 2402 to 2483 MHz
Max. Output power: +4dBm
Single power supply: 1.8 – 3.6V
Range: up to 60 meters in open space
Chip: nRF52811 (Nordic)
GPIO Quantity: 32
192KB Flash and 24KB RAM
Module size: 20.0 x 12.0 x 2.0 mm
ARM Cortex-M4F processor
Metal shielding with marking
3 optional antenna types: PCB antenna, chip antenna, IPEX connector
Operating Temperature range: -30 to 80 degree Celsius

Application

Medical devices
Heart rate monitor
Blood pressure monitor
Blood glucose meter
Thermometer
Sport facilities
Weighing machine
Sports and fitness sensors
Accessories
3D glasses and gaming controller
Mobile accessories
Remote controllers / Toys
Electronic devices
Cycle computer

Certification

Full Bluetooth Declaration ID: D039669
FCC ID:2ABU6-MS50SFB
TELEC: 208-190043
IC: 20896-MS50SFB
CE, RCM, WPC, RoHS & REACH certified

Revision history

Version	Date	Notes	Contributor (s)	Person of Approve
1.0	2019.07.01	Initial release	Lynn	

Index

Revision history.....	2
1. Product introduction.....	5
1.1 Ordering information.....	5
2. Pin description.....	6
2.1 Pin assignment.....	6
2.2 Pin definition.....	6
2.3 Block diagram.....	8
2.4 Mechanical drawing.....	9
3. Electrical specification.....	9
3.1 Absolute maximum ratings.....	9
3.2 Recommended operating conditions.....	10
3.3 Electronic characteristic.....	11
3.3.1 General radio characteristics.....	11
3.3.2 Radio current consumption (Transmitter).....	11
3.3.3 Radio current consumption (Receiver).....	12
3.3.4 Transmitter specification.....	12
3.3.5 Receiver operation.....	13
3.3.6 RX selectivity.....	13
3.3.7 RX intermodulation.....	15
3.3.8 Radio timing.....	16
3.3.9 Received signal strength indicator (RSSI) specifications.....	17
4. Electrical schematic.....	18
5. Package information.....	19
5.1 Package dimension.....	19
5.2 Mark on metal shield.....	20
6. Reflow and soldering.....	20

7. Certification.....	21
7.1 Full Bluetooth Declaration ID.....	21
7.2 Europe (CE).....	21
7.3 United States (FCC).....	21
7.4 Canada (IC).....	22
7.5 Japan (TELEC).....	22
7.6 Australia / New Zealand (RCM).....	22
7.8 Environmental.....	23
7.8.1 RoHS.....	23
7.8.2 Reach.....	23
8. Notes & cautions.....	24
8.1 Design notes.....	24
8.2 Layout notes.....	24
8.3 Installation and soldering.....	25
8.4 Handling and storage	25
8.5 Life support applications	26
9. Disclaimer.....	26
10. Contact information.....	27

1. Product introduction

The MS50SFB3 is a compact and small size Bluetooth 5.1 module with ultra-low power consumption; The module has the large number of GPIOs and excellent RF performance. Therefore, it can apply to a wide range of Bluetooth connected products. With an ARM Cortex™ M4(F) MCU, up to 192KB flash, 24KB RAM, embedded 2.4GHz, MS50SFB can save the R&D and time cost.

The module is highly integrated that contains all the necessary components from radio to a different antenna and a completely implemented Bluetooth protocol stack and programming UART communication protocol.

1.1 Ordering information

Ordering number	Description
MS50SFB_V3.0	316060315,nRF52811-QFAA, with IPEX antenna, with metal shielding cover

2. Pin description

2.1 Pin assignment

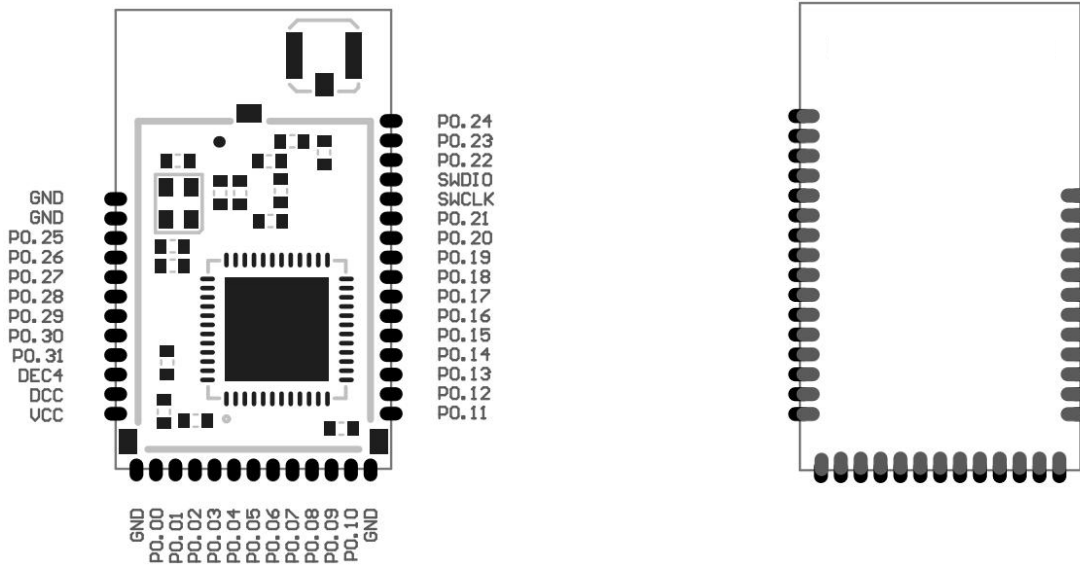

2.2 Pin definition

Symbol	Type	Description
P0.00	Digital I/O	General purpose I/O
XL1	Analog input	Connection for 32.768 kHz crystal (LFXO)
P0.01	Digital I/O	General purpose I/O
XL2	Analog input	Connection for 32.768 kHz crystal (LFXO)
P0.02	Digital I/O	General purpose I/O
AIN 0	Analog input	SAADC/COMP/LPCOMP input
P0.03	Digital I/O	General purpose I/O
AIN 1	Analog input	SAADC/COMP/LPCOMP input
P0.04	Digital I/O	General purpose I/O
AIN 2	Analog input	SAADC/COMP/LPCOMP input

P0.05 AIN 3	Digital I/O Analog input	General purpose I/O SAADC/COMP/LPCOMP input
P0.06	Digital I/O	General purpose I/O
P0.07	Digital I/O	General purpose I/O
P0.08	Digital I/O	General purpose I/O
P0.09	Digital I/O	General purpose I/O
P0.10	Digital I/O	General purpose I/O
GND	Ground	
P0.11	Digital I/O	General purpose I/O
P0.12	Digital I/O	General purpose I/O
P0.13	Digital I/O	General purpose I/O
P0.14 TRACEDATA[3]	Digital I/O	General purpose I/O Trace port output
P0.15 TRACEDATA[2]	Digital I/O	General purpose I/O Trace port output
P0.16 TRACEDATA[1]	Digital I/O	General purpose I/O Trace port output
P0.17	Digital I/O	General purpose I/O
P0.18 TRACEDATA[0] / SWO	Digital I/O	General purpose I/O Single wire output Trace port output
P0.19	Digital I/O	General purpose I/O
P0.20 TRACECLK	Digital I/O	General purpose I/O Trace port clock output
P0.21 nRESET	Digital I/O	General purpose I/O Configurable as pin reset
P0.22	Digital I/O	General purpose I/O
P0.23	Digital I/O	General purpose I/O
P0.24	Digital I/O	General purpose I/O
P0.25	Digital I/O	General purpose I/O
P0.26	Digital I/O	General purpose I/O
P0.27	Digital I/O	General purpose I/O

P0.28	Digital I/O	General purpose I/O
AIN4	Analog input	SAADC/COMP/LPCOMP input
GND	Ground	
P0.29	Digital I/O	General purpose I/O
AIN5	Analog input	SAADC/COMP/LPCOMP input
P0.30	Digital I/O	General purpose I/O
AIN6	Analog input	SAADC/COMP/LPCOMP input
P0.30	Digital I/O	General purpose I/O
AIN7	Analog input	SAADC/COMP/LPCOMP input
SWCLK	Digital input	Serial wire debug clock input for debug and programming
SWDIO	Digital I/O	Serial wire debug I/O for debug and programming
DCC	Power	DC/DC regulator output
VCC	Power	

2.3 Block diagram

2.3.3 MS50SFB/IPEX antenna

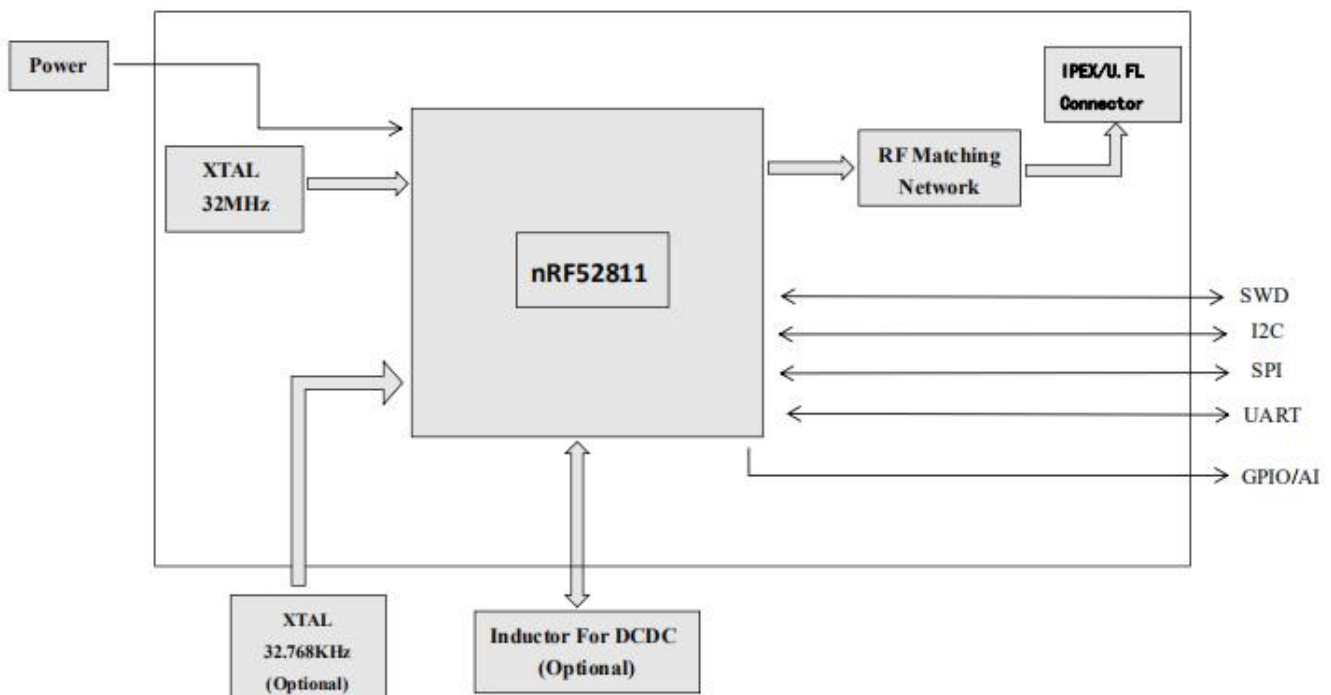

2.4 Mechanical drawing

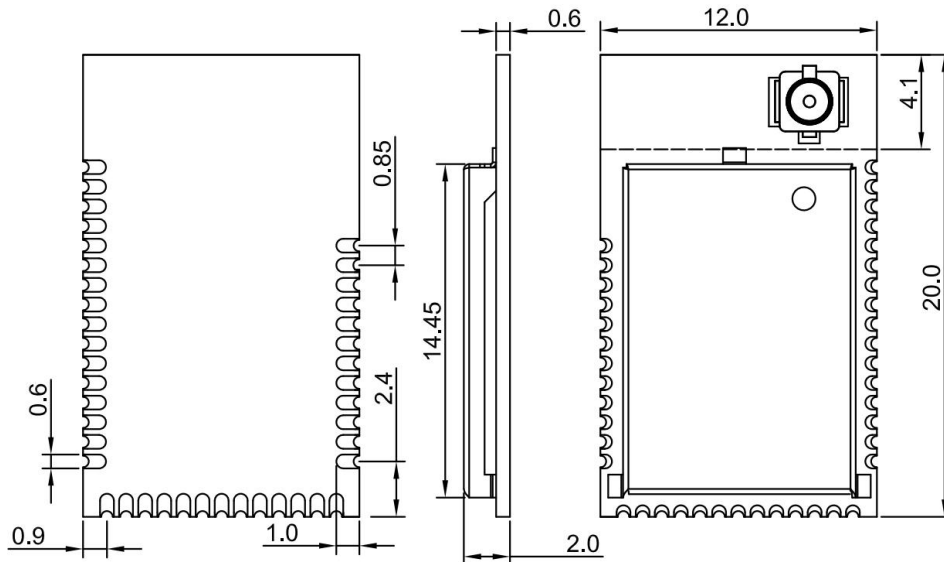

Unit: mm

Tolerance: +/- 0.1, default

3. Electrical specification

The electrical specifications of the module are directly related to the Nordic semiconductor Specifications for the nRF52811 chipset. The below information is only the extract from nRF52811 specification. For more detailed information, please refer to the up-to-date specification of the chipset available on the Nordic semiconductor website.

3.1 Absolute maximum ratings

	Min.	Max.	Unit
Supply voltages			
VDD	-0.3	+3.9	V
VSS		0	V

I/O pin voltage			
$V_{I/O}, V_{DD} \leq 3.6 \text{ V}$	-0.3	$V_{DD} + 0.3 \text{ V}$	V
$V_{I/O}, V_{DD} > 3.6 \text{ V}$	-0.3	3.9V	V
Radio			
RF input level		10	dBm
Environmental QFN48, 6×6 mm package			
Storage temperature	-40	+125	°C
MSL(moisture sensitivity level)		2	
ESD HBM		3	kV
ESD HBM Class (Human Body Model Class)		2	
ESD CDM(charged device model)		1	kV

Important: Maximum ratings are the extreme limits to which the chip can be exposed for a limited amount of time without permanently damaging it. Exposure to absolute maximum ratings for prolonged periods of time may affect the reliability of the device.

3.2 Recommended operating conditions

The operating conditions are the physical parameters that the chip can operate within.

Symbol	Parameter	Notes	Min.	Nom.	Max.	Units
VDD	Supply voltage, independent of DCDC enable		1.7	3.0	3.6	V
T_{R_VDD}	Supply rise time (0 V to 1.7 V)				60	ms
TA	Operating temperature		-40	25	85	°C

Important: The on-chip power-on reset circuitry may not function properly for rise times longer than the specified maximum.

3.3 Electronic characteristic

3.3.1 General radio characteristics

Symbol	Description	Min.	Typ.	Max.	Units
f_{OP}	Operating frequencies	2360		2500	MHz
$f_{PLL,CH,SP}$	PLL channel spacing		1		MHz
$f_{DELTA,1M}$	Frequency deviation @ 1 Msps		± 170		kHz
$f_{DELTA,BLE,1M}$	Frequency deviation @ BLE 1 Msps		± 250		kHz
$f_{DELTA,2M}$	Frequency deviation @ 2 Msps		± 320		kHz
$f_{DELTA,BLE,2M}$	Frequency deviation @ BLE 2 Msps		± 500		kHz
f_{skSPS}	On-the-air data rate	125		2000	kbps
$f_{chip, IEEE 802.15.4}$	Chip rate in IEEE 802.15.4 mode		2000		

3.3.2 Radio current consumption (Transmitter)

Symbol	Description	Min.	Typ.	Max.	Units
$I_{TX,PLUS4dBm,DCDC}$	TX only run current(DC/DC,3V) $P_{RF}=+4$ dBm		7.0		mA
$I_{TX,PLUS4dBm}$	TX only run current $P_{RF}=+4$ dBm		15.4		mA
$I_{TX,0dBm,DCDC}$	TX only run current(DC/DC,3V) $P_{RF}=0$ dBm		4.6		mA
$I_{TX,0dBm}$	TX only run current $P_{RF}=0$ dBm		10.1		mA
$I_{TX,MINUS4dBm,DCDC}$	TX only run current DC/DC,3V $P_{RF}=-4$ dBm		3.6		mA
$I_{TX,MINUS4dBm}$	TX only run current $P_{RF}=-4$ dBm		7.8		mA
$I_{TX,MINUS8dBm,DCDC}$	TX only run current DCDC,3V $P_{RF}=-8$ dBm		3.2		mA
$I_{TX,MINUS8dBm}$	TX only run current $P_{RF}=-8$ dBm		6.8		mA
$I_{TX,MINUS12dBm,DCDC}$	TX only run current DCDC,3V $P_{RF}=-12$ dBm		2.9		mA
$I_{TX,MINUS12dBm}$	TX only run current $P_{RF}=-12$ dBm		6.2		mA
$I_{TX,MINUS16dBm,DCDC}$	TX only run current DCDC,3V $P_{RF}=-16$ dBm		2.7		mA
$I_{TX,MINUS16dBm}$	TX only run current $P_{RF}=-16$ dBm		5.7		mA
$I_{TX,MINUS20dBm,DCDC}$	TX only run current DCDC,3V $P_{RF}=-20$ dBm		2.5		mA
$I_{TX,MINUS20dBm}$	TX only run current $P_{RF}=-20$ dBm		5.4		mA

$I_{TX,MINUS40dBm,DCDC}$	TX only run current DCDC,3V $P_{RF}=-40$ dBm		2.1		mA
$I_{TX,MINUS40dBm}$	TX only run current $P_{RF}=-40$ dBm		4.3		mA
$I_{START,TX,DCDC}$	TX start-up current (DCDC,3V), $P_{RF}=4$ dBm				mA
$I_{START,TX}$	TX start-up current $P_{RF}=4$ dBm				mA

3.3.3 Radio current consumption (Receiver)

Symbol	Description	Min.	Typ.	Max.	Units
$I_{RX,1M,DCDC}$	RX only run current (DCDC, 3V) 1MSPS / 1MSPS BLE		4.6		mA
$I_{RX,1M}$	RX only run current 1MSPS / 1MSPS BLE		10.0		mA
$I_{RX,2M,DCDC}$	RX only run current (DCDC, 3V) 2MSPS / 2MSPS BLE		5.2		mA
$I_{RX,2M}$	RX only run current (LDO,3V)2MSPS / 2MSPS BLE		11.2		mA
$I_{START,RX,DCDC}$	RX start-up current (DCDC 3V)1 Mbps/1 Mbps BLE		3.5		mA
$I_{START,RX,LDO}$	RX start-up current 1 Mbps/1 Mbps BLE		6.7		mA

3.3.4 Transmitter specification

Symbol	Description	Min.	Typ.	Max.	Units
P_{RF}	Maximum output power		4.0		dBm
P_{RFC}	RF power control range		24		dB
P_{RFCR}	RF power accuracy			± 4	dB
$P_{RF1,1}$	1st Adjacent Channel Transmit Power 1 MHz (1 Mbps Nordic proprietary mode)		-25		dBc
$P_{RF2,1}$	2nd Adjacent Channel Transmit Power 2 MHz (1 Mbps Nordic proprietary mode)		-50		dBc
$P_{RF1,2}$	1st Adjacent Channel Transmit Power 2 MHz (2 Mbps Nordic proprietary mode)		-25		dBc
$P_{RF2,2}$	2nd Adjacent Channel Transmit Power 4 MHz (2 Mbps Nordic proprietary mode)		-50		dBc
Evm	Error vector magnitude IEEE 802.15.4		12		%rms

$P_{\text{harm2nd, IEEE}}$ 802.15.4	2nd harmonics in IEEE 802.15.4 mode		-45		dBm
$P_{\text{harm3rd, IEEE}}$ 802.15.4	3rd harmonics in IEEE 802.15.4				dBm

3.3.5 Receiver operation

Symbol	Description	Min.	Typ.	Max.	Units
$P_{\text{RX,MAX}}$	Maximum received signal strength at < 0.1% BER		0		dBm
$P_{\text{SENS,IT,1M}}$	Sensitivity, 1 Mbps nRF mode ideal transmitter		-94		dBm
$P_{\text{SENS,IT,2M}}$	Sensitivity, 2 Mbps nRF mode ideal transmitter		-91		dBm
$P_{\text{SENS,IT,SP,1M,BLE}}$	Sensitivity, 1Msps BLE ideal transmitter, <=37 bytes BER=1E-32		-97		dBm
$P_{\text{SENS,IT,LP,1M,BLE}}$	Sensitivity, 1Msps BLE ideal transmitter >=128 bytes BER=1E-4 ³		-96		dBm
$P_{\text{SENS,IT,LP,2M,BLE}}$	Sensitivity, 2 Mbps BLE ideal transmitter, packet length ≤ 37		-94		dBm
$P_{\text{SENS,IT,BLE}}$ LE125k	Sensitivity, 125 kbps BLE mode		-104		dBm
$P_{\text{SENS,IT,BLE}}$ LE500k	Sensitivity, 500 kbps BLE mode		-100		dBm
$P_{\text{SENS,IEEE}}$ 802.15.4	Sensitivity in IEEE 802.15.4 mode		-101		dBm

3.3.6 RX selectivity

Symbol	Description	Min.	Typ.	Max.	Units
$C/I_{1\text{M,co-channel}}$	1Msps mode, Co-Channel interference		9		dBm
$C/I_{1\text{M,-1MHz}}$	1 Msps mode, Adjacent (-1 MHz) interference		-2		dBm
$C/I_{1\text{M,+1MHz}}$	1 Msps mode, Adjacent (+1 MHz) interference		-10		dBm
$C/I_{1\text{M,-2MHz}}$	1 Msps mode, Adjacent (-2 MHz) interference		-19		dBm
$C/I_{1\text{M,+2MHz}}$	1 Msps mode, Adjacent (+2 MHz) interference		-42		dBm
$C/I_{1\text{M,-3MHz}}$	1 Msps mode, Adjacent (-3 MHz) interference		-38		dBm

$C/I_{1M,+3MHz}$	1 Msps mode, Adjacent (+3 MHz) interference		-48		dB
$C/I_{1M,\pm 6MHz}$	1 Msps mode, Adjacent (≥ 6 MHz) interference		-50		dB
$C/I_{1MBLE,co-channel}$	1 Msps BLE mode, Co-Channel interference		6		dB
$C/I_{1MBLE,-1MHz}$	1 Msps BLE mode, Adjacent (-1 MHz) interference		-2		dB
$C/I_{1MBLE,+1MHz}$	1 Msps BLE mode, Adjacent (+1 MHz) interference		-9		dB
$C/I_{1MBLE,-2MHz}$	1 Msps BLE mode, Adjacent (-2 MHz) interference		-22		dB
$C/I_{1MBLE,+2MHz}$	1 Msps BLE mode, Adjacent (+2 MHz) interference		-46		dB
$C/I_{1MBLE,>3MHz}$	1 Msps BLE mode, Adjacent (≥ 3 MHz) interference		-50		dB
$C/I_{1MBLE,image}$	Image frequency Interference -22 dB		-22		dB
$C/I_{1MBLE,image,1MHz}$	Adjacent (1 MHz) interference to in-band image frequency		-35		dB
$C/I_{2M,co-channel}$	2 Msps mode, Co-Channel interference		10		dB
$C/I_{2M,-2MHz}$	2 Msps mode, Adjacent (-2 MHz) interference		6		dB
$C/I_{2M,+2MHz}$	2 Msps mode, Adjacent (+2 MHz) interference		-14		dB
$C/I_{2M,-4MHz}$	2 Msps mode, Adjacent (-4 MHz) interference		-20		dB
$C/I_{2M,+4MHz}$	2 Msps mode, Adjacent (+4 MHz) interference		-44		dB
$C/I_{2M,-6MHz}$	2 Msps mode, Adjacent (-6 MHz) interference		-42		dB
$C/I_{2M,+6MHz}$	2 Msps mode, Adjacent (+6 MHz) interference		-47		dB
$C/I_{2M,\geq 12MHz}$	2 Msps mode, Adjacent (≥ 12 MHz) interference		-52		dB
$C/I_{2MBLE,co-channel}$	2 Msps BLE mode, Co-Channel interference		6		dB
$C/I_{2MBLE,\pm 2MHz}$	2 Msps BLE mode, Adjacent (± 2 MHz) interference		-2		dB
$C/I_{2MBLE,\pm 4MHz}$	2 Msps BLE mode, Adjacent (± 4 MHz) interference		-48		dB
$C/I_{2MBLE,\geq 6MHz}$	2 Msps BLE mode, Adjacent (≥ 6 MHz) interference		-50		dB
$C/I_{2MBLE,image}$	Image frequency Interference		-29		dB
$C/I_{2MBLE,image,2MHz}$	Adjacent (2 MHz) interference to in-band image frequency		-44		dB
$C/I_{125k BLE LR,co channel}$	125 kbps BLE LR mode, Co-Channel interference		4		dB
$C/I_{125k BLE LR,-1MHz}$	125 kbps BLE LR mode, Adjacent (-1 MHz) interference		-9		dB

C/I125k BLE LR,+1MHz	125 kbps BLE LR mode, Adjacent (+1 MHz) interference		-16		dB
C/I125k BLE LR,-2MHz	125 kbps BLE LR mode, Adjacent (-2 MHz) interference		-30		dB
C/I125k BLE LR,+2MHz	125 kbps BLE LR mode, Adjacent (+2 MHz) interference		-50		dB
C/I125k BLE LR,>3MHz	125 kbps BLE LR mode, Adjacent (≥ 3 MHz) interference		-55		dB
C/I125k BLE LR,image	Image frequency interference		-30		dB
C/IIEEE 802.15.4,-5MHz	IEEE 802.15.4 mode, Adjacent (-5 MHz) rejection		33		dB
C/IIEEE 802.15.4,+5MHz	IEEE 802.15.4 mode, Adjacent (+5 MHz) rejection		38		dB
C/IIEEE 802.15.4, 10MHz	IEEE 802.15.4 mode, Alternate (10 MHz) rejection		48		dB

3.3.7 RX intermodulation

Symbol	Description	Min.	Typ.	Max.	Units
$P_{\text{IMD,STH,1M}}$	IMD performance, 1 Mbps, 5th offset channel, packet length ≤ 37 bytes		-33		dBm
$P_{\text{IMD,STH,1M, BLE}}$	IMD performance, BLE 1 Mbps, 5th offset channel, packet length ≤ 37 bytes		-30		dBm
$P_{\text{IMD,STH,2M}}$	IMD performance, 2 Mbps, 5th offset channel, packet length ≤ 37 bytes		-33		dBm
$P_{\text{IMD,STH,2M, BLE}}$	IMD performance, BLE 2 Mbps, 5th offset channel, packet length ≤ 37 bytes		-31		dBm

3.3.8 Radio timing

Symbol	Description	Min.	Typ.	Max.	Units
$t_{TXEN,BLE,1M}$	Time between TXEN task and READY event after channel FREQUENCY configured (1 Mbps BLE and 150 μ s TIFS)	140		140	μ s
$t_{TXEN,FAST,BLE,1M}$	Time between TXEN task and READY event after channel FREQUENCY configured (1 Mbps BLE with fast ramp-up and 150 μ s TIFS)	40		40	μ s
$T_{TXDIS,BLE,1M}$	When in TX, delay between DISABLE task and DISABLED event for MODE = Nrf_1Mbit and MODE = Ble_1Mbit	6		6	μ s
$T_{RXEN,BLE,1M}$	Time between the RXEN task and READY event after channel FREQUENCY configured (1 Mbps BLE)	140		140	μ s
$t_{RXEN,FAST,BLE,1M}$	Time between the RXEN task and READY event after channel FREQUENCY configured (1 Mbps BLE with fast ramp-up)	40		40	μ s
$t_{RXDIS,BLE,1M}$	When in RX, delay between DISABLE task and DISABLED event for MODE = Nrf_1Mbit and MODE = Ble_1Mbit	0		0	μ s
$t_{TXDIS,BLE,2M}$	When in TX, delay between DISABLE task and DISABLED event for MODE = Nrf_2Mbit and MODE = Ble_2Mbit	4		4	μ s
$t_{RXDIS,BLE,2M}$	When in RX, delay between DISABLE task and DISABLED event for MODE = Nrf_2Mbit and MODE = Ble_2Mbit	0		0	μ s
$t_{TXEN,IEEE}$ 802.15.4	Time between TXEN task and READY event after channel FREQUENCY configured (IEEE 802.15.4)	130		130	μ s
$t_{TXEN,FAST,IEEE}$ 802.15.4	Time between TXEN task and READY event after channel FREQUENCY configured (IEEE 802.15.4 with fast ramp-up)	40		40	μ s
$t_{TXDIS,IEEE}$ 802.15.4	When in TX, delay between DISABLE task and DISABLED event (IEEE 802.15.4)	21		21	μ s
$t_{RXEN,IEEE}$ 802.15.4	Time between the RXEN task and READY event after channel	130		130	μ s
$t_{RXEN,FAST,IEEE}$ 802.15.4	Time between the RXEN task and READY event after channel	40		40	μ s

t _{RXDIS,IEEE} 802.15.4	When in RX, delay between DISABLE task and DISABLED event (IEEE 802.15.4)	0.5		0.5	
t _{RX-to-TX} turnaround	Maximum TX-to-RX or RX-to-TX turnaround time in IEEE 802.15.4 mode		40		

3.3.9 Received signal strength indicator (RSSI) specifications

Symbol	Description	Min.	Typ.	Max.	Units
RSSI _{ACC}	RSSI Accuracy Valid range -90 to -20 dBm		±2		dB
RSSI _{RESOLUTION}	RSSI resolution		1		dB
RSSI _{PERIOD}	Sample period		0.25		us
RSSI _{SETTLE}	RSSI settling time after signal level change		15		us

4. Electrical schematic

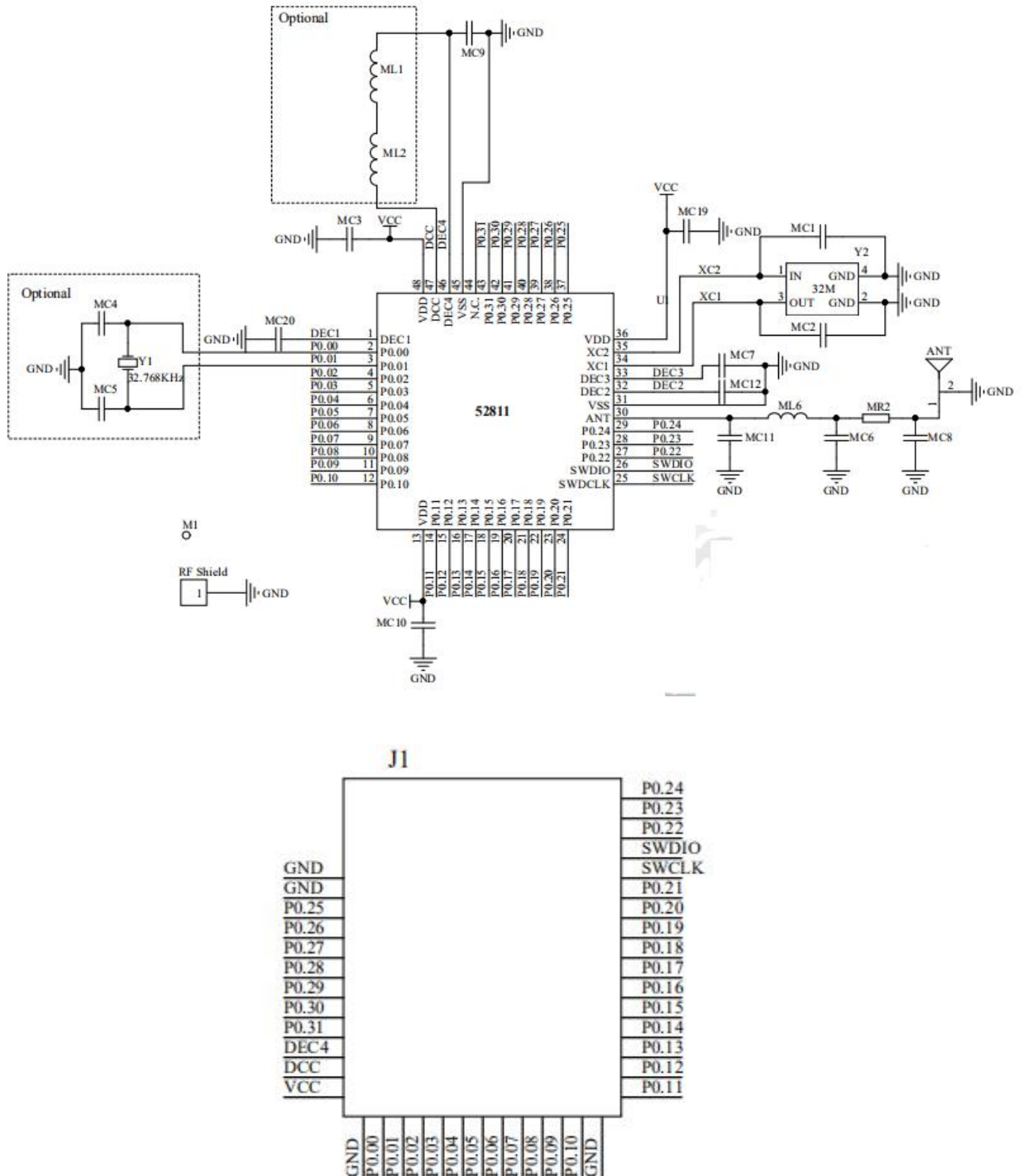

5. Package information

5.1 Package dimension

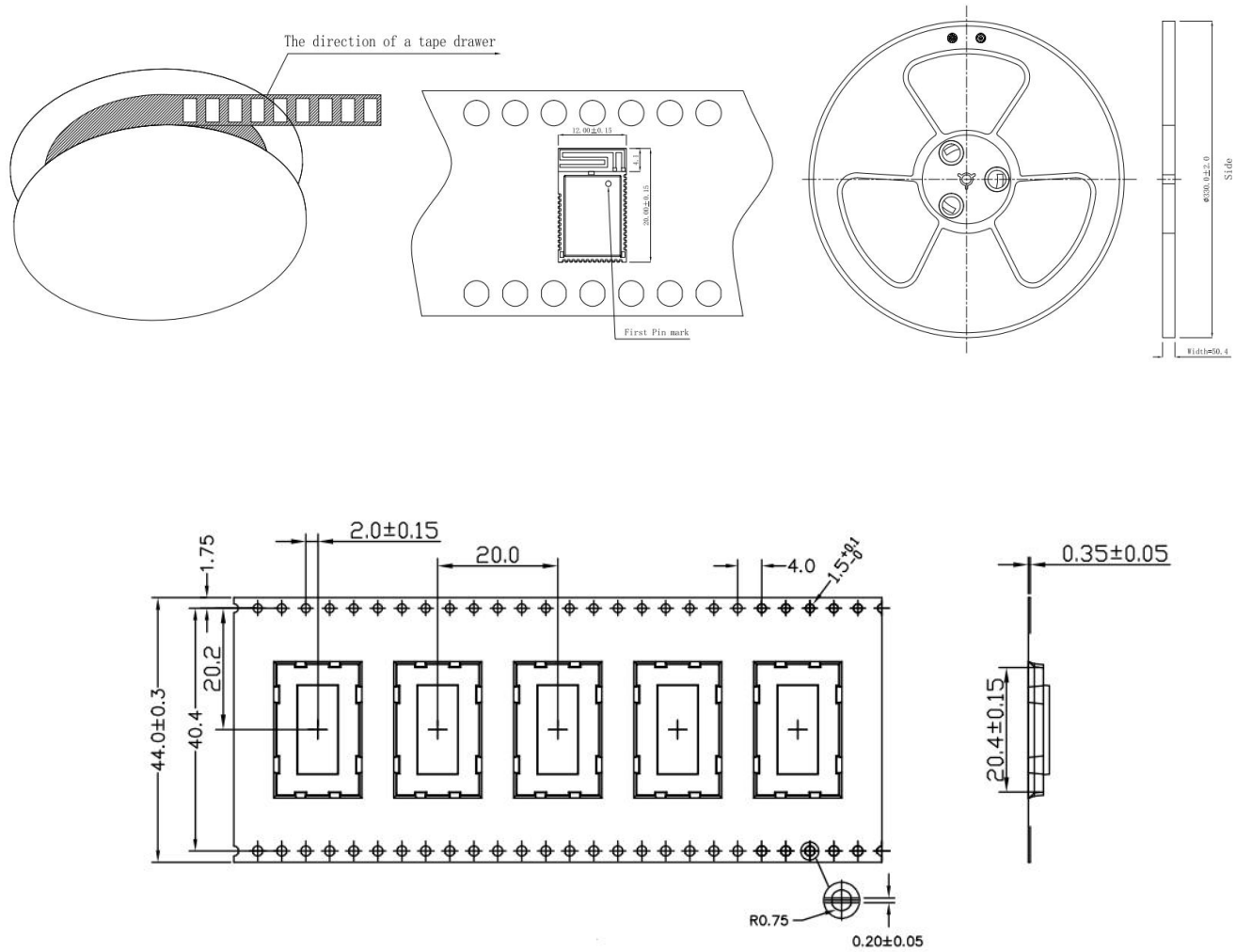

Details	Reel-MS50SFB3
Quantity(module)	850PCS
Tape Weight	515g
Single module Weight	0.72g
Gross Weight	1150g
Dimension	W: 44mm T: 0.35mm

5.2 Mark on metal shield

MS50SFB

QDID:111267

FCC ID:2ABU6-MS50SFB



6. Reflow and soldering

6.Reflow profile

Reflow condition (Follow of JEDEC STD-020D.01)

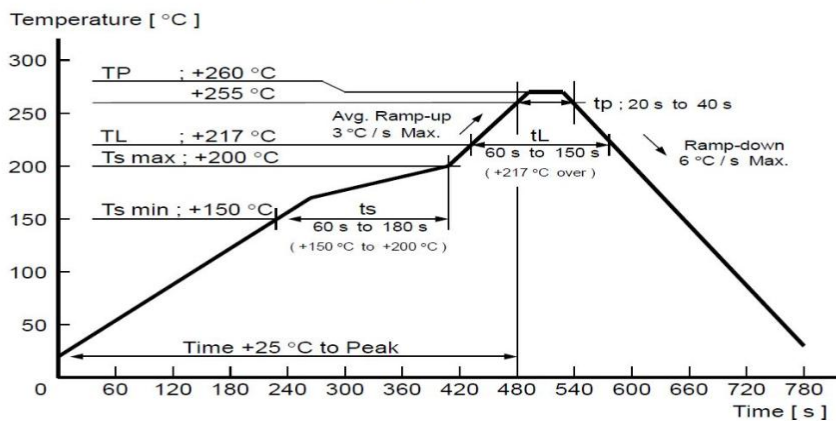

Profile Feature	Sn-Pb Assembly	Pb-Free Assembly
Solder Paste	Sn63/Pb37	Sn96.5/Ag3/Cu0.5
Preheat Temperature min (Tsmín)	100°C	150°C
Preheat Temperature max (Tsmáx)	150°C	200°C
Preheat Time (Tsmín to Tsmáx)(ts)	60-120 sec	60-120 sec
Average ramp-up rate (Tsmáx to Tp)	3°C/second max	3°C/second max
Liquidous Temperature (TL)	183°C	217°C
Time (tL) Maintained Above (TL)	60-90 sec	30-90 sec
Peak Temperature (Tp)	220-235°C	230-250°C
Average ramp-down rate (Tp to Tsmáx)	6°C/second max	6°C/second max
Time 25°C to peak temperature	6 minutes max	8 minutes max

7. Certification

7.1 Full Bluetooth Declaration ID

Please kindly check the DID number for MS50SFB: D039669.

Minew technologies meet the bluetooth specification maintained by Bluetooth SIG, and all the product produced by Minew is properly tested and comply with the Bluetooth license agreements.

Minew is one of the associate member of Bluetooth SIG. The requirement of listing products by companies is become the members of the SIG and also pay the listed fees for each product required.

Please Kindly check the below Link to know more info:

<https://www.bluetooth.com/develop-with-bluetooth/qualification-listing>.

The Minew Bluetooth Low Energy modules based on Nordic Semiconductor SoCs are listed as a “End product”.

7.2 Europe (CE)

MS50SFB module is being tested and is expected to be compliant against the EU-Radio Equipment standards. OEM integrator should consult with qualified test house to verify all regulatory requirements have been met for their complete device.

7.3 United States (FCC)

Please kindly check the FCC ID for MS50SFB: 2ABU6-MS50SFB.

MS50SFB module is being tested and is expected to be compliant against the Federal Communications Commission standards.

As for the OEM integration:

Only OEM integrator have right to intend this device under the following conditions:

Any other transmitter or antenna must not be co-located with the antenna and transmitter. The module shall be only used with the integral antenna(s) that has been originally tested and certified with this module.

As long as the two conditions below are met, further transmitter testing will not be required.

- (1) This device may not cause harmful interference, and
- (2) this device must accept any interference received, including interference that may cause undesired operation.

However, the OEM integrator shall test their end-product for any additional compliance requirements with this module installed (for example, digital device emission, PC peripheral requirements, etc.).

If these conditions cannot be met (for example certain laptop configuration or co-location with another transmitter), then the FCC authorization for this module in combination with the host equipment is no longer considered valid and the final product shall not use the FCC ID of the module. In these circumstances, the OEM integrator shall be re-evaluating the end product (including the transmitter) and obtaining a separate FCC authorization.

The OEM shall be verifying end product compliance with FCC Part 15, sub-part B limits for unintentional radiators through an accredited test facility.

7.4 Canada (IC)

Please kindly check the IC ID for MS50SFB: 20896-MS50SFB.

Minew's modules have been certified for use in Canada under Industry Canada (IC) Radio Standards Specification (RSS) RSS-210 and RSSGen. Modular approval permits the installation of a module in a host device without the need to rectify the device.

As for the labeling & user Information Requirements, MS50SFB is assigned the IC ID number: 20896-MS50SFB

Labeling Requirements for the Host Device (from Section 3.2.1, RSS-Gen, Issue 3, December 2010): The host device shall be properly labeled to identify the module within the host device.

User Manual Notice for License-Exempt Radio Apparatus (from Section 7.1.3 RSS-Gen, Issue 3, December 2010): User manuals for license-exempt radio apparatus shall contain the following or equivalent notice in a conspicuous location in the user manual or alternatively on the device or both: This device complies with Industry Canada license exempt RSS standard(s).

Operation is subject to the following two conditions:

- (1) this device may not cause interference,
- and (2) this device must accept any interference, including interference that may cause undesired operation of the device.

Transmitter Antenna (from Section 7.1.2 RSS-Gen, Issue 3, December 2010): User manuals for transmitters shall display the following notice in a conspicuous location:

Under Industry Canada regulations, this radio transmitter may only operate using an antenna of a type and maximum (or lesser) gain approved for the transmitter by Industry Canada. To reduce potential radio interference to other users, the antenna type and its gain should be so chosen that the equivalent isotropically radiated power (e.i.r.p.) is not more than that necessary for successful communication.

7.5 Japan (TELEC)

Please kindly check the TELEC ID for MS50SFB: 208-190043.

The MS50SFB is approved for use in the Japanese market.

7.6 Australia / New Zealand (RCM)

The MS50SFB has been tested to comply with the AS/NZS 4268:2017, Radio equipment and systems –Short range devices – Limits and methods of measurement. It may be used as evidence in obtaining permission to use the Regulatory Compliance Mark (RCM).

Information on registration as a Responsible Party, license and labeling requirements may be found at the following websites:

Australia: <http://www.acma.gov.au/theACMA/radiocommunications-short-range-devices-standard->

2004.

New Zealand: <http://www.rsm.govt.nz/compliance>.

Only Australian-based and New Zealand-based companies who are registered may be granted permission to use the RCM. An Australian-based or New Zealand-based agent or importer may also register as a Responsible Party to use the RCM on behalf of a company not in Australia or New Zealand.

7.7 India (WPC)

The MS50SFB has been tested to comply with the wireless planning & coordination (WPC) Wing of the Ministry of Communications standard. WPC created in 1952, is the National Radio Regulatory Authority responsible for Frequency Spectrum Management, including licensing and caters for the needs of all wireless users (Government and Private) in the country.

It exercises the statutory functions of the Central Government and issues licenses to establish, maintain and operate wireless stations. WPC is divided into major sections like Licensing and Regulation (LR), New Technology Group (NTG) and Standing Advisory Committee on Radio Frequency Allocation (SACFA). SACFA makes the recommendations on major frequency allocation issues, formulation of the frequency allocation plan, making recommendations on the various issues related to International Telecom Union (ITU), to sort out problems referred to the committee by various wireless users, Siting clearance of all wireless installations in the country etc.

7.8 Environmental

7.8.1 RoHS

MS50SFB modules are in compliance with Directive 2011/65/EU, 2015/863/EU of the European Parliament and the Council on the restriction of the use of certain hazardous substances in electrical and electronic equipment.

7.8.2 Reach

MS50SFB modules listed below do not contain the 191 SVHC (Substance of Very High Concern), as defined by Directive EC/1907/2006 Article according to REACH Annex XVII.

8. Notes & cautions

We cannot assure that the specification has no errors and omission even though this specification is under collate and check strictly.

This specification is under the protection of laws and regulations of copyright, please do not copy and duplicate at any form, or do not transmit part or full of this specification in any wire and wireless network in any form, or do not edit or translate to any other format, word, code, etc.

8.1 Design notes

(1) It is critical to following the recommendations of this document to ensure the module meets the specifications.

(2) The module should be placed at the edge of the circuit board as far as possible to keep away from other circuits.

(3) Antenna should be kept away from other circuits. It can prevent low radiation efficiency and the normal use of other circuits from being affected.

(4) The landing of components should be appropriate and that is better for reducing the parasitic inductance.

(5) Please refuse to supply voltage that is not within the range of specification.

(6) Please make sure the module or its surface may not suffer from the physical shock or extreme stress.

8.2 Layout notes

To make sure wireless performance is at its best condition, please layout the MS50SFB1 and MS50SFB2 module on the carrier board as below instructions and picture.

(1) Placement of the antenna

The antenna area of module shall lay clearance completely and should not be blocked by the metal. Otherwise it will have effect on antenna performance (As the picture indicated below).

(2) Placement of top-layer

The placement of top-layer in carrier board shall be lay copper completely to reduce the signal line in carrier board or other interference.

(3) Clearance

The upper and below area of antenna (including the case) shall have 4mm or more than 4mm

clearance to reduce the influences for antenna.

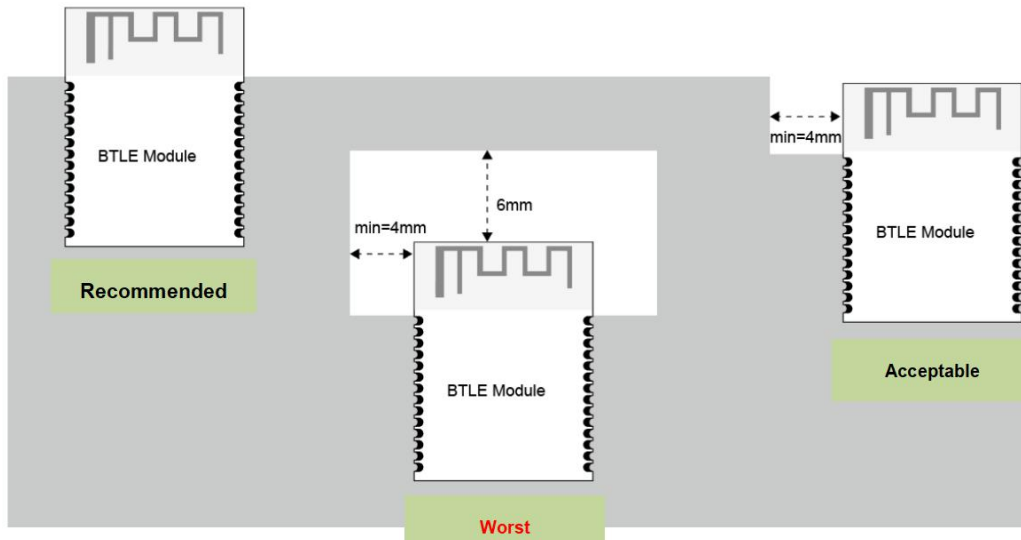

*The Grey area above is Carrier board.

8.3 Installation and soldering

(1) Please do not lay copper under the module antenna. It can prevent the influence of signal radiation and the transmission distance from being affected.

8.4 Handling and storage

(1) Due to the fact that CMOS components are included in the module, it is better to eliminate static electricity at any methods when transporting or working with the module. Moreover, it is strongly recommended adding anti-ESD components to circuit design to hinder damage from real-life ESD events. Anti-ESD methods can be also used in mechanical design.



(2) Please store the modules within -40°C to $+125^{\circ}\text{C}$ before and after installation and make sure the modules is away from the direct sunlight exposure for a long duration. Modules should be far away from humid and salty air conditions, and any corrosive gasses or substances.

(3) Please not to wash the module. No-Clean Paste is used in production. The metal shield may be oxidized by the washing process and may lead to chemistry reaction with No-Clean Paste. If modules goes through the washing process, functions of the module may not guaranteed.

8.5 Life support applications

(1) The module is not design for life support device or system and not allowed to be used in destructive devices or system in any direct, or indirect ways. Minew is not responsible for compensation of any losses when applying modules under such application as described above.

(2) Minew shall not responsible for the customer's products or application.

9. Disclaimer

The factory has passed the ISO9001 quality management system, ISO14001 environmental management system and OAHS18001 occupational health and safety assessment . Each product has been rigorously tested (transmission power test, sensitivity test, power consumption test, stability test, aging test, etc.).

* NOTICES:

- (1) The Bluetooth trade mark is owned by the Bluetooth SIG Inc. USA.
- (2) All other trademarks listed herein are owned by their respective owners.
- (3) All specifications are subject to change without notice.
- (4) Please do not use this specification for produce, sell or illegal purpose without Minew's authorization.
- (5) Minew have right to interpret all the items above.

10. Contact information

Manufacturer: Shenzhen Minew Technologies Co., Ltd.

Tel: 0086-755-2103 8160

Email: info@Minew.com

URL: <https://www.minew.com/>

Address:

3rd Floor, Building I,
Gangzhilong Science Park,
Qinglong Road, Longhua District,
Shenzhen 518109,
China