

## Embedded Medium-power Radio Data Transceiver SV650

### Description

SV650 is an embedded ultra-small size of the high-power high integrated wireless module, using high-performance Silicon Lab Si4432 RF chip. Receiver sensitivity coupled with low industry-leading 500 mW output power guaranteed expand the scope and improve the link performance. Module provides a multi-band multi-channel and network ID to reduce interference during transmission to improve the transmission performance. Users can connect via PC software or devices via the serial port, and an RF Online is set to modify the relevant parameters.



### Feature

- 3000m RF line-in-sight distance@1.2kbps
- 433/470/868/915 MHz
- 40 channels
- 4 bytes net ID
- 2 bytes node ID
- Multiple air data rate
- GFSK modulation
- antenna match automatically and bi-direction switch control
- Support Serial port parameter setting
- Sensitivity: -121 dBm
- Max output power: 500 mW
- Voltage: 3.3 ~ 7.5 V
- Temperature: -40 ~ +85 °C

### Application

- Remote telemetry
- Auto meter reading
- Security systems
- Data logger
- Wireless data communication
- Building residential automation and security
- Healthy monitoring
- Wireless PC peripherals
- Access Control System
- Robot control

## Electrical Specifications

Parameter	Min.	Typ.	Max.	Unit	Conditions
Operation conditions					
Supply Voltage	3.3	5.0	7.5	V	
Operating Temperature	-40	25	+85	°C	
Current consumption					
RX Current		25		mA	TTL
		34		mA	485
TX current		350		mA	@27dBm
Sleep Current		≤5		uA	
RF parameter					
Frequency	414.92	433.92	453.92	MHZ	@433MHZ
	470.92	470.92	509.92	MHZ	@470MHZ
	849.92	868.92	888.92	MHZ	@868MHZ
	895.92	914.92	934.92	MHZ	@915MHZ
Air data rate	1.2	9.6	38.4	Kbps	GFSK
Output power	20	/	+27	dBm	Setting by software
Sensitivity		-121		dBm	@1.2kbps

## Technical specification

### 5.1. Parameter configuration

In configuration mode, users can set the parameters by PC tool or in circuit through UART port. The parameters include channels, frequency, air data rate, out put power, serial port baud rate, data bit, stop bit, parity bit, NET ID and NODE ID. The detailed communication protocol is shown in the programming manual.

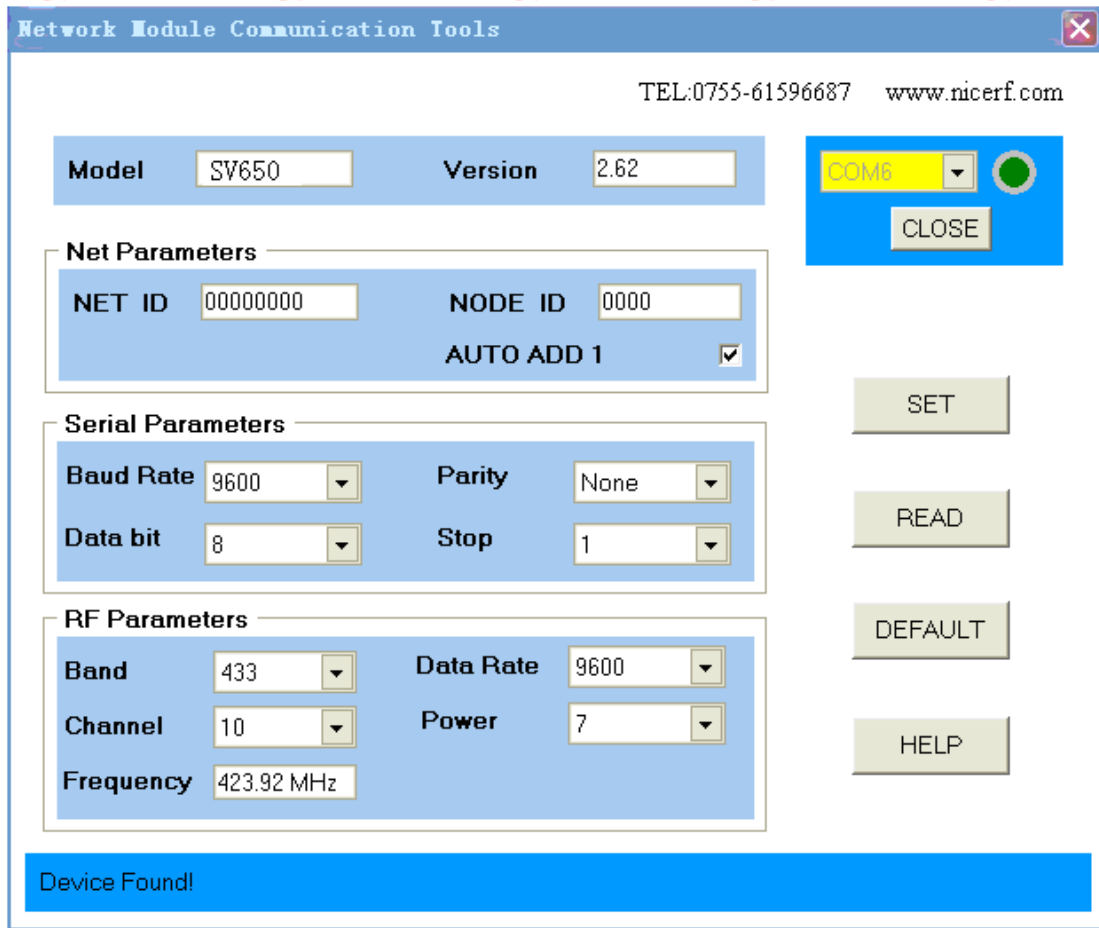

Figure 1: Interface of setting tool

Parameter	Length (byte)	Explanation
Frequency	1	433MHz / 470MHz / 868MHz / 915MHz
Channel	1	1 ~ 40
Air data rate	1	1200/2400/4800/9600/14400/19200/38400 bps
Output power level	1	0~7 level
UART baud rate	1	1200/2400/4800/9600/14400/19200/38400 bps
UART Data bit	1	7, 8, 9
UART stop bit	1	1, 2
UART parity	1	No, Odd, Even

Table 1: Parameter specification

## 5.2. RSSI function (Optional)

Module has two versions. If users choose the version with RSSI function, the instruction will retrieve the module and receive a data packet of RSSI value in configuration mode.

### 5.3. Data transmitting

When module is in transmitting mode, data from serial port can be sent via RF chip modulation into the air toward targeted module of the link layer forwarding. When the targeted module receives the RF data from the source, it also converts it into a serial signal and output to the device of the target.

In order to ensure the stability and correctness of the data transmitting, user should pay attention to the following issues:

#### 1) RX/TX Match

In the same network, in order to ensure available of communication, all modules must be in same condition. That means all the parameters such as frequency, channel, net ID are same. The module has a 4-byte network ID. It can not communicate with each other between the different network ID configuration modules. When the network ID is set to all 0, this module can receive any data information.

#### 2) Latency

Since the wireless communication transmitting device receives from the terminal end of a certain amount of data, or wait a certain time before the new data does not start transmitting, the radio communication transmitting end to the receiving end there is a wireless communication delay, the other from the wireless communication terminal apparatus receiving end it will take some time, but the delay time under the same conditions is fixed (specific time is determined by serial rate, air rate determined by the size).

#### 3) Data traffic

Inside the module has a 200-byte buffer, when the serial data rate less than or equal wireless transmission rate can be guaranteed data transfer smoothly, but if the serial port rate is greater than the wireless transmission rate, continuously sending data bytes exceeds the buffer size may data overflow occurs as a result of data loss. Therefore, large amounts of data for continuous transmission, to avoid data loss or errors, you can set the parameters so that the serial transmission rate does not exceed the wireless transmission rate.

## 5.4, Sleep mode

When CS pin is set to low, module is in sleep mode. User can't do any operation for the module.

The power consumption is low to 5uA.

## Accessories

### 1) Antenna

The antenna is an important part of the communication system. Its feature directly affects the performance of the communication system. The match impedance of module is 50 ohms, we recommend that users adopt standard spring antenna.



### 2) USB Bridge Board

Modules needed by configuration tool to configure the relative parameters. The Company supplies a USB interface matching plate adapter with TTL/RS485 level, so that users can quickly and easily with the PC side communication.

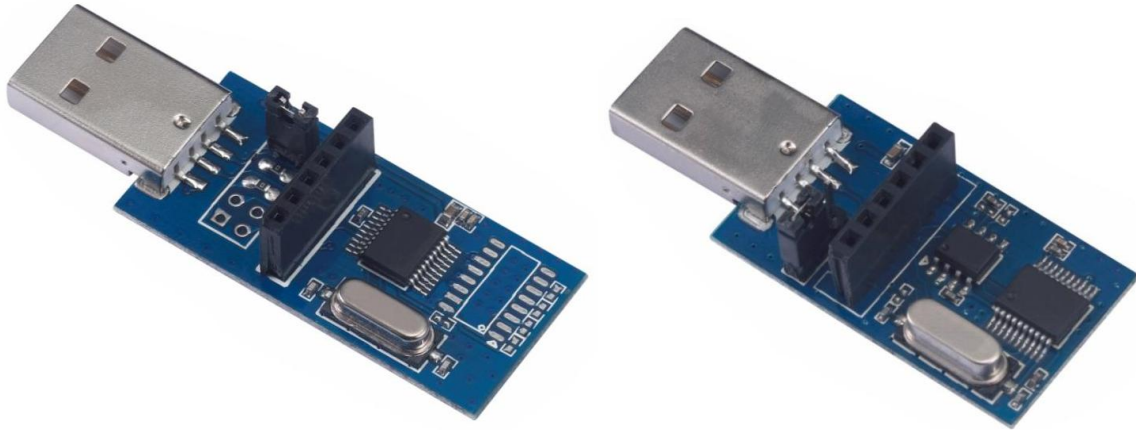

### Schematic

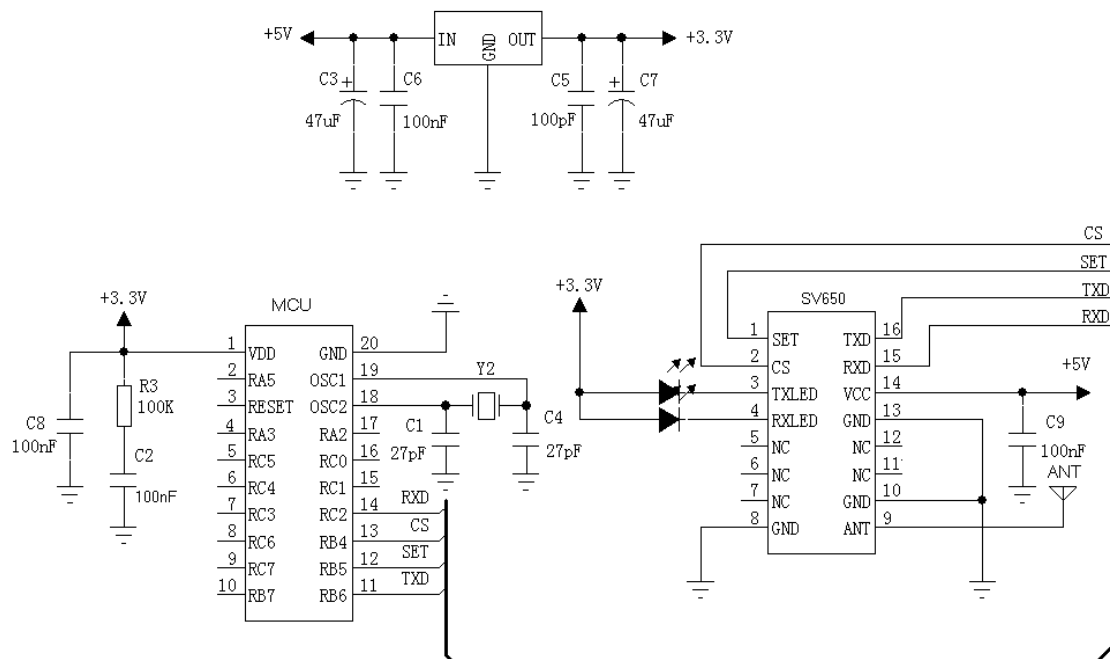

### Pinouts

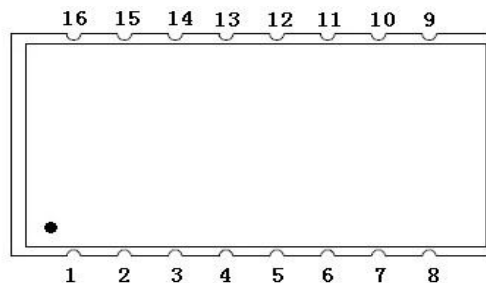

Pin Number	Pin Definitions	Description
1	SET	Configuration parameters enable (low to enable the configuration parameters, the default high-level output)

2	CS	The module is enabled (low dormancy, the current is less than 5uA, the default high-level output)
3	TXLED	Emitted light output pin (active low)
4	RXLED	Receive indicator output pin (active low)
5、6、7、11、12	NC	Vacant
8、10、13	GND	Connected to power ground
9	ANT	RF signal output, then a 50 ohm antenna
14	VCC	Connected to the positive power supply (typical 5V)
15	TXD/A	Serial communication data transmission (@ 485 level, then the output of A)
16	RXD/B	Serial communication data reception (@ 485 level, then the output B)

### Mechanical dimensions

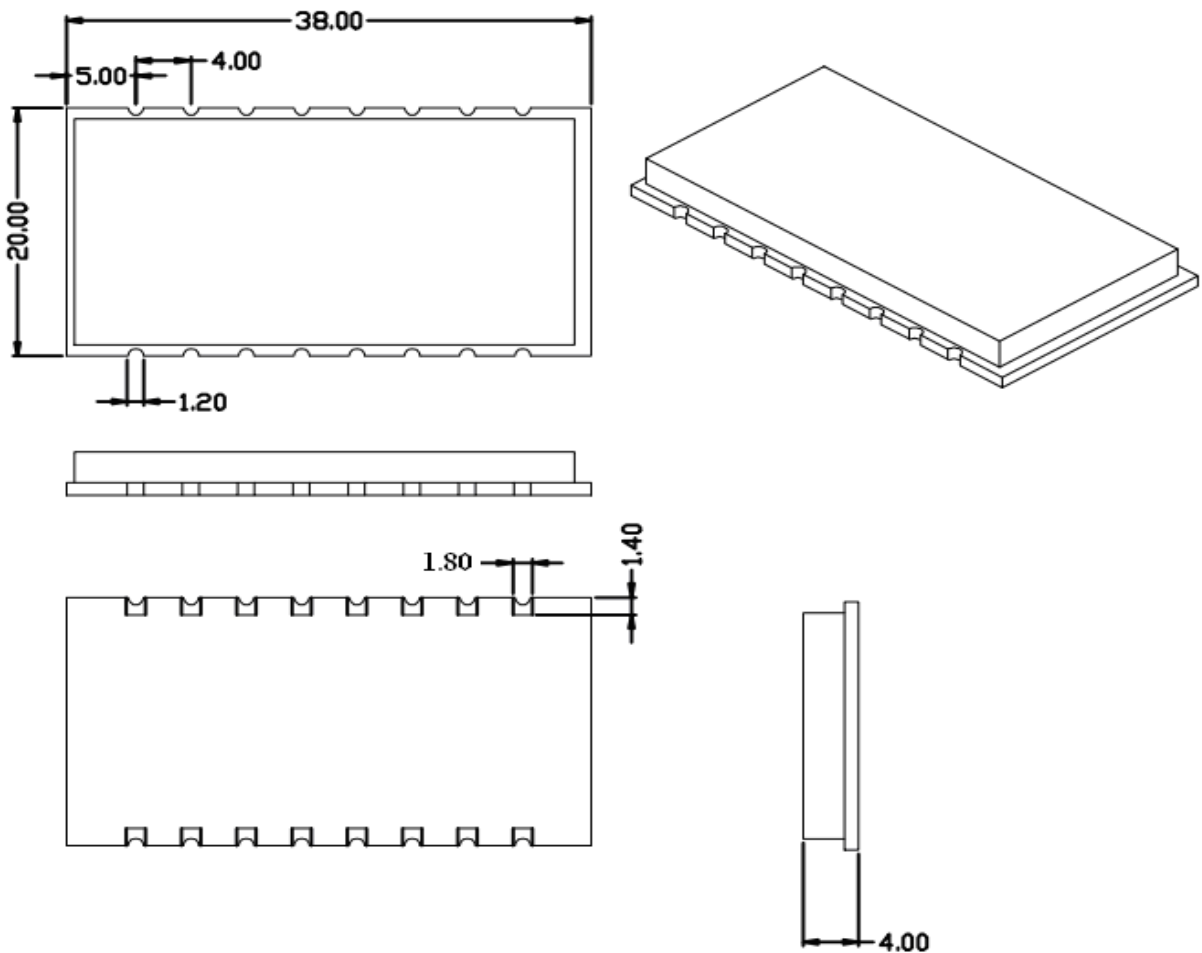

### Product Ordering Information

SV650- 433



For example: If the customer needs 433MHZ band module that orders Model: SV650-433

The SV650 product following models:

Order a single Model	Product type
SV650- 433	433MHZ, Chip module
SV650- 470	470MHZ, Chip module
SV650- 868	868MHZ, Chip module
SV650- 915	915MHZ, Chip module

### Relative Q&A

- a) Why module can not communicate properly?
  - 1) Check the band, channel, rate, NET ID is set to the same;
  - 2) The power connection error, the module is not working;
  - 3) Module is enabled (CS high);
  - 4) The antenna connection is not correct;
  - 5) Module is damaged.
- b) Why far transmission distance?
  - 1) Power supply ripple is too large;
  - 2) The antenna types do not match, or not properly installed;
  - 3) The surrounding environment is harsh, strong interference sources;
  - 4) Surrounding co-channel interference;
- c) Why is receiving data correctly?
  - 1) Improper parameter settings;
  - 2) Module data interface is bad.