

HARDWARE REFERENCE

IMM-NRF52832-NANO

Module

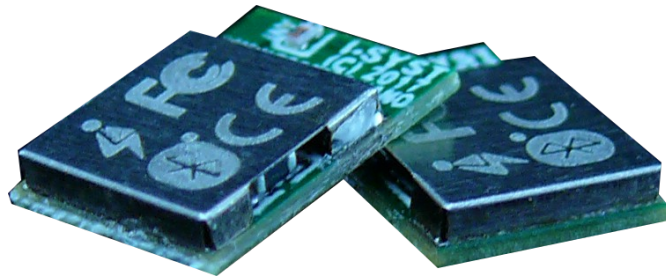

Part No : IBLE832N

Copyright © 2018 I-SYST, all rights reserved.

This document may not be reproduced in any form without, express written consent from I-SYST.

Limited Warranty

The IMM-NRF52832-NANO module is warranted against defects in materials and workmanship for a period of 30 days from the date of purchase from I-SYST or from an authorized dealer.

Disclaimer

I-SYST reserves the right to change this product without prior notice. Information furnished by I-SYST is believed to be accurate and reliable. However, no responsibility is assumed by I-SYST for its use; nor for any infringement of patents nor other rights of third parties which may result from its use. No license is granted by implication or otherwise under the patent rights of I-SYST.

In no event shall I-SYST be liable for any direct, indirect, incidental, special, exemplary, or consequential damages (including, but not limited to, procurement of substitute goods or services; loss of use, data, or profits; or business interruption) however caused and on any theory of liability, whether in contract, strict liability, or tort (including negligence or otherwise) arising in any way out of the use of I-SYST hardware and software, even if advised of the possibility of such damage.

I-SYST products are not designed for use in life support appliances, devices, or systems where malfunction of these products can reasonably be expected to result in personal injury.

I-SYST customers using or selling these products for use in such applications do so at their own risk and agree to fully indemnify I-SYST for any damages resulting from such improper use or sale.

Trademark

ARM® Cortex™ are registered trade mark of ARM

Bluetooth® is a registered trade mark of Bluetooth SIG

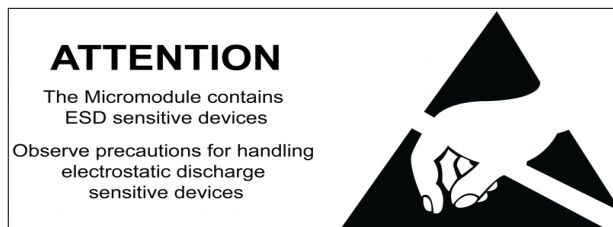

Table of Contents

Introduction.....	1
<i>Features:.....</i>	<i>1</i>
Module Layout.....	2
<i>Dimensions and I/O pins layout.....</i>	<i>2</i>
<i>SMD Footprint.....</i>	<i>4</i>
Quick Start.....	5
<i>Requirements.....</i>	<i>5</i>
<i>Flashing firmware.....</i>	<i>5</i>
<i>Breakout board.....</i>	<i>5</i>
<i>J-Tag wiring.....</i>	<i>6</i>
<i>Nordic Software.....</i>	<i>6</i>
<i>Eclipse IDE.....</i>	<i>6</i>

Introduction

The nRF52832 is an ultra low power System on Chip (SoC) from Nordic Semiconductor. It integrates the nRF52 series 2.4GHz transceiver, a 32 bits ARM® Cortex™-M4F MCU, Flash memory, analog and digital I/O. The nRF52832 supports ANT+, Bluetooth 5 Low Energy and proprietary protocols.

The IMM-NRF52832-NANO is a 10 x 7 x 1.6 mm module with embedded PCB antenna. It allows developers to take full advantage of the nRF52832 by making all its I/O available via 34 SMD 0.5mm pitch pads.

Features:

- 32 bits ARM® Cortex™-M4F @ 64MHz.
- 2.4GHz transceiver, Bluetooth 5 LE, ANT+
- 64KB SRAM.
- 512KB Flash
- 32 MHz Crystal 25PPM
- 32.768 KHz Crystal 20PPM
- DC/DC power mode configuration
- 30 configurable I/O pins
- Type 2 NFC-A Tag with wakeup on field
- 8 configurable 12 bits, 200 ksps ADC
- Digital microphone interface
- 3 x 4 channels PWM
- AES hardware encryption
- RNG, RTC
- Temperature sensor
- Up to 4 PWM
- Digital interfaces SPI Master/Slave, 2-wire Master (I2C compatible), UART (CTS/RTS)
- Quadrature decoder
- Low power comparator
- Operating voltage : 1.8V to 3.6V
- Dimension : 10 x 7 x 1.6 mm

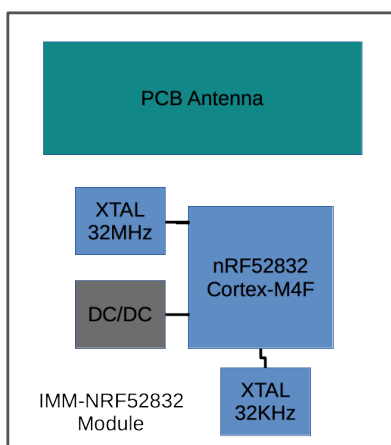

Module Layout

Dimensions and I/O pins layout

Bellow is the direct relationship of the module pads and the nRF52832 I/O pins.

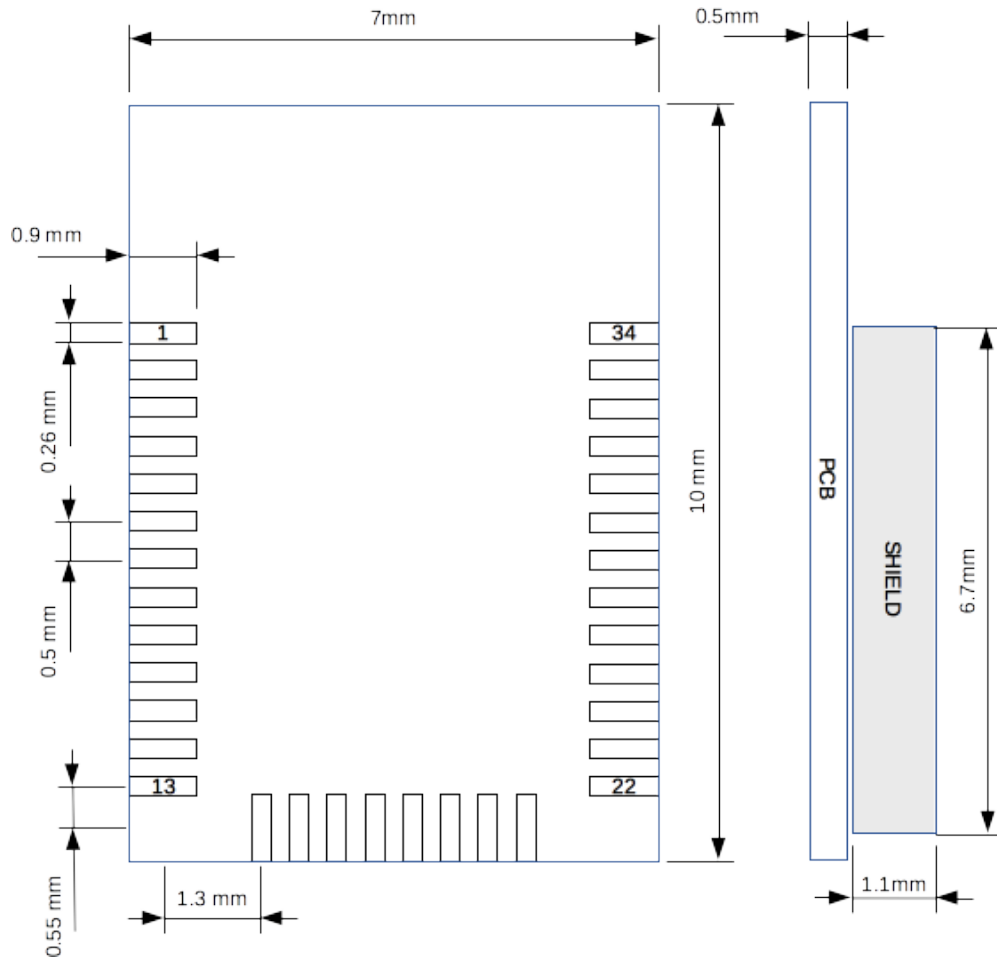

Fig. 1: Dimensions top view

Pin Number	Pin Name	Description
1	P0.22	GPIO 22
2	P0.21/nRESET	GPIO 21 or RESET active low
3	P0.20	GPIO 20
4	P0.19	GPIO 19
5	P0.18	GPIO 18
6	P0.17	GPIO 17
7	P0.16	GPIO 16
8	P0.15	GPIO 15
9	P0.14	GPIO 14
10	P0.13	GPIO 13
11	P0.12	GPIO 12
12	P0.11	GPIO 11
13	P0.10/NFC2	GPIO 10 or NFC2 tag
14	P0.09/NFC1	GPIO 9 or NFC1 tag
15	P0.08	GPIO 8
16	P0.07	GPIO 7
17	P0.06	GPIO 6
18	SWDIO	JTAG Data
19	SWDCLK	JTAG Clock
20	VDD	Power 1.8V-3.6V
21	GND	Ground
22	P0.05/AIN3	GPIO 5 or Analog Input 3
23	P0.04/AIN2	GPIO 4 or Analog Input 2
24	P0.03/AIN1	GPIO 3 or Analog Input 1
25	P0.02/AIN0	GPIO 2 or Analog Input 0
26	P0.31/AIN7	GPIO 31 or Analog Input 7
27	P0.30/AIN6	GPIO 30 or Analog Input 6
28	P0.29/AIN5	GPIO 29 or Analog Input 5
29	P0.28/AIN4	GPIO 28 or Analog Input 4
30	P0.27	GPIO 27
31	P0.26	GPIO 26
32	P0.25	GPIO 25
33	P0.24	GPIO 24
34	P0.23	GPIO 23

SMD Footprint

Note : Do not route any traces or planes under the indicated antenna area.

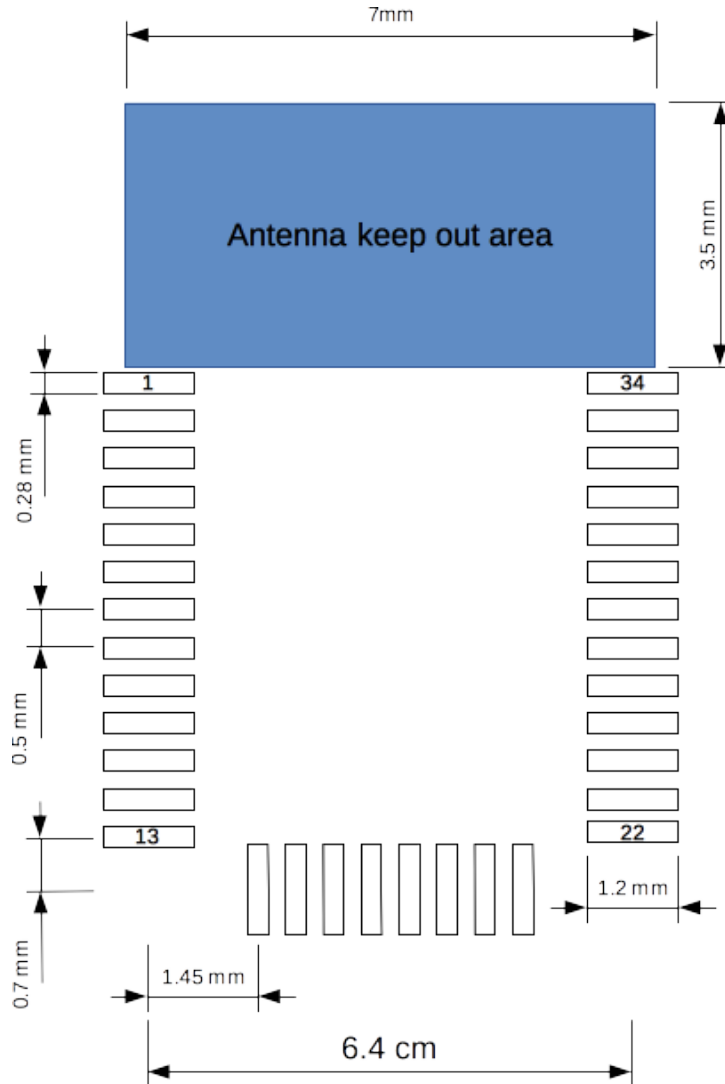

Fig. 2: SMD footprint

Quick Start

Requirements

The follows are required for software development

- Debug J-Tag : IDAP-Link, Segger J-Link, or any ARM compatible J-Tag.
- Nordic SDK & Softdevice ANT & BLE stack (<https://developer.nordicsemi.com/>)
- C/C++ embedded software development environment : Eclipse, Keil, CrossWorks, ...

Flashing firmware

The Nordic Softdevice is required to use ANT & BLE application. There are many methods to flash it in the module. The official method from Nordic is to use nRFGo with J-Link. This program is available only on Windows operating system. The other method is to use IDAP-Link with IDAPnRFProg for OSX & Windows. More details available on blog page <http://embeddedsoftdev.blogspot.ca/p/ehal-nrf51.html>. The IDAPnRFProg can program Softdevice, DFU and Firmware app without requiring mergehex. It can parallel program multiple nRF51 boards at once when multiple IDAP-Link are connected to PC..

Breakout board

The module can also be mounted on the optional breakout board, the IBK-BLUEIO-NANO. This breakout board has all I/O pins routed out to standard DIP32, 2.54mm pitch header pin, with onboard LED indicator and coin battery holder. Ready to be mounted on a breadboard. The SWD pins are also routed out for debug probe. Connect it to the IDAP-Link for OpenOCD debugging or turn the IMM-NRF52832-NANO into mBed compatible.

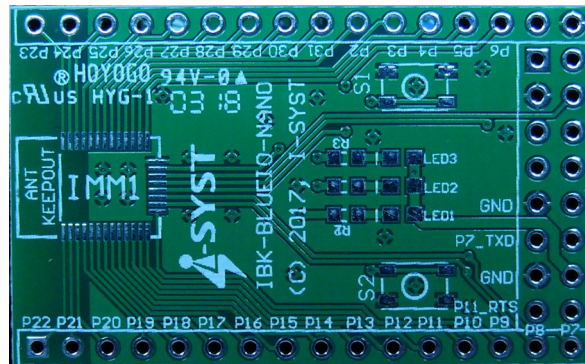

Fig. 3: IBK-BLUEIO-NANO.

Breakout PCB for the IMM-NRF52832-NANO module

J-Tag wiring

The IMM-NRF52832-NANO module has exposed the SWD (Serial Wire Debug) pins SWDIO & SWCLK, see I/O layout section. The module can be directly connected to a J-Tag tool for development by wiring the 2 SWD and the optional Reset pins to the appropriate pins on the J-Tag connector. The VIN must be wire to the VCC pin on the J-Tag. GND pad is also require to be connected to GND on J-Tag.

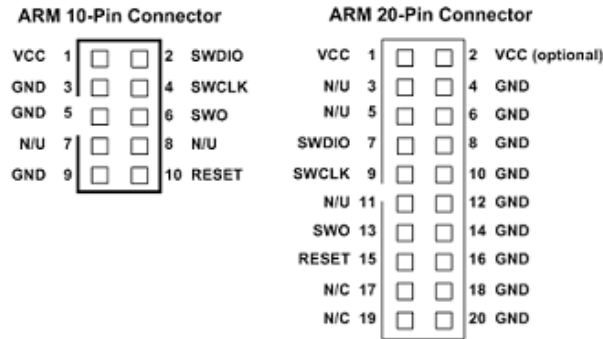

Fig. 4: ARM JTAG Connector

The module can be powered from 1.8V to 3.6V on VIN. It could be coin battery or DC supply source.



Fig. 5: IDAP-Link JTag with IBK-BLUEIO-NANO for development with the IMM-NRF52832-NANO module

Nordic Software

The Nordic SDK and software tools can be download from <http://developer.nordicsemi.com> and <http://www.nordicsemi.com>. Community support forum at <https://devzone.nordicsemi.com>.

Eclipse IDE

Eclipse with GCC is the most cost effective software development environment. It is 100% free. The drawback is that it requires a bit of gymnastics to setup. Fortunately many Blog posts are available on the Internet showing step by step. Follow this blog to setup the Eclipse IDE & GCC compiler: <http://embeddedsoftdev.blogspot.ca/p/eclipse.html>.

There are samples code in the Nordic SDK itself. Other Eclipse based example code are available from this Blog page <http://embeddedsoftdev.blogspot.ca/p/ehal-nrf51.html>