

DESCRIPTION DOCUMENT FOR WIFI TWO DIMMER ONE AMPERES BOARD

HARDWARE REVISION 0.1

Department	Name	Signature	Date
Author			
Reviewer			
Approver			

Revision History

Rev	Description of Change	Effective Date
A	Initial Release	

ABSTRACT:

This document is a detailed product description that describes the effective features of the product. It includes a functional hardware description of the product with its internal block diagram and product images.

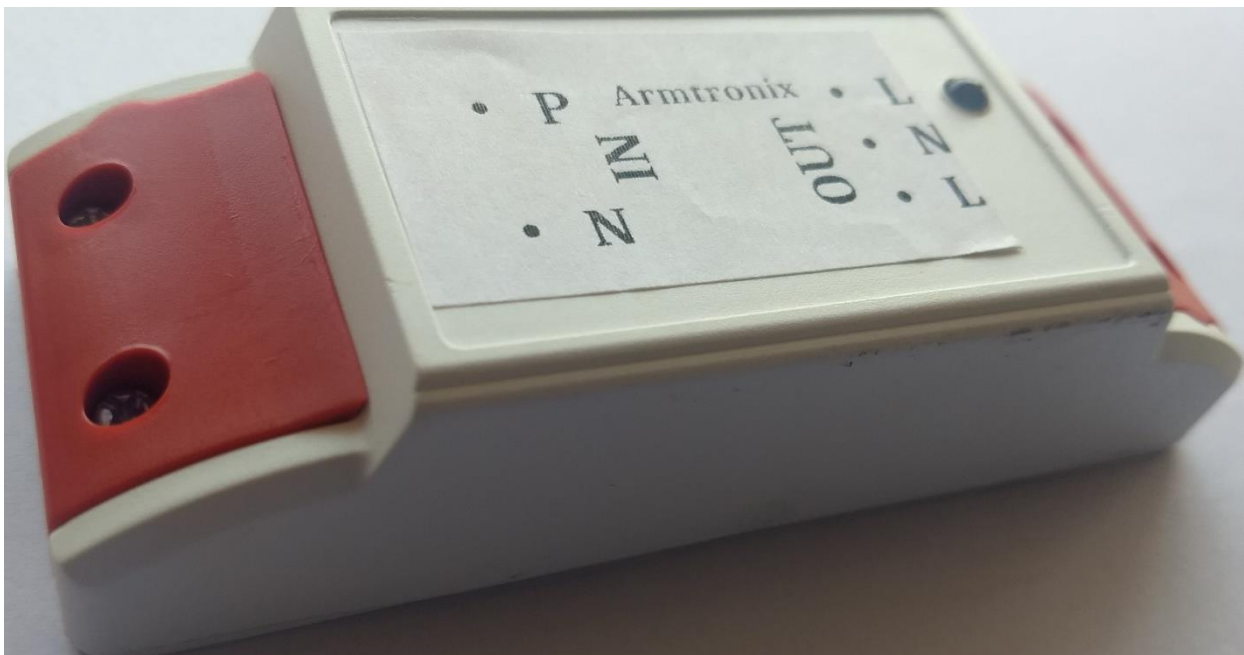

Table of Contents

Revision History	1
1. ABBREVIATIONS	3
2. REFERENCES	3
3. PURPOSE	3
4. SCOPE	3
5. SAFETY AND WARNING	3
6. INTRODUCTION	4
7. PRODUCT FEATURES	4
8. PRODUCT DESCRIPTION	4
a. PHYSICAL DESCRIPTION	4
b. FUNCTIONAL DESCRIPTION	5
9. SYSTEM OVERVIEW	5
10. TECHNICAL SPECIFICATION	6
a. ELECTRICAL SPECIFICATION	6
b. MECHANICAL SPECIFICATION	6
11. ELECTRICAL CONNECTIONS.....	7
12. HOW TO USE THE PRODUCT	9
13. HOW TO CUSTOMISE FIRMWARE.....	10
a. STEPS TO LOAD PROGRAM TO ESP8266:	10
b. STEPS TO LOAD PROGRAM TO ATMEGA328P:	13
IMPORTANT NOTICE	14

Table of figures

Figure 1: Block Diagram	5
Figure 2: Header and Switch Details	7
Figure 3: AC Input connection.....	7
Figure 4: Triac pin-out.....	7
Figure 5: Load connection.....	8
Figure 6: Other Header	8
Figure 7: Device hosting Access point.....	9
Figure 8: Access point name	9
Figure 9: Web server	9
Figure 10: Board Selection	11
Figure 11: IDE Selection	11
Figure 12: COM port selection.	12
Figure 13: Executing code	12

1. ABBREVIATIONS

Term	Description
A	Ampere
AC	Alternating Current
COM	Communication
DC	Direct Current
GPIO	General Purpose Input Output
HTTP	Hypertext Transfer Protocol
Hz	Hertz
I2C	Inter Integrated Circuit
IDE	Integrated Development Environment
IP	Internet Protocol
LED	Light Emitting Diode
MCU	Microcontroller Unit
MQTT	Message Queue Telemetry Transport
PCB	Printed Circuit Board
PWM	Pulse Width Modulation
SPI	Serial Peripheral Interface
SSID	Service Set Identifier
UART	Universal Asynchronous Receiver Transmitter
V	Volts
ZCD	Zero Crossover Detection

2. REFERENCES

Company Website link	https://www.armtronix.in
Intractable's Weblink	http://www.instructables.com/id/Wifi-Two-Triac-Dimmer-Board/
Github's Weblink	https://github.com/armtronix/Wifi-Two-Dimmer-Board

3. PURPOSE

The purpose of this document is to outline the design description for the Wifi 2-TRIAC 1A Board. It provides a high level summary of the product.

4. SCOPE

This document describes system architecture which includes Power supply, Microcontroller, WiFi Module and Triac.

5. SAFETY AND WARNING

Note that, this board to be powered with AC 230V with required current. Work and handle carefully with AC power as it is harmful and danger for human beings. Touching live wire or board when it is ON is danger and not advisable, it may cause to death, please avoid it.

Even a 50 V AC supply is sufficient to kill you. Please Switch off the mains before you make or change connections, be very careful. If you are not sure of anything related to the AC supply lines, please call an electrician ask and him to help you with it. Do not attempt to interface to mains unless you have adequate training and access to appropriate safety equipment. Never work on high voltages by yourself when you are alone. Always ensure that you have a friend/partner who can see and hear you and who knows how to quickly turn off power in case

of an accident. Use a 2A Fuse in series with the input to the board as a safety measure. Basic Wiring diagram is available on our instructables page and github. Please refer it.

Fire Hazard: Making wrong connections, drawing more than rated power, contact with water or other conducting material, and other types of misuse/overuse/malfunction can all cause overheating and risk starting a fire. Test your circuit and the environment in which it is deployed thoroughly before leaving it switched on and unsupervised. Always follow all fire safety precautions.

6. INTRODUCTION

Two Triac One Ampere board is a Wifi based remote control switch/dimmer product. Designed and developed to control lights and/or fans. Using this board the lights and fans can be controlled through Smartphone which you use regularly. This board is not just to switch ON/OFF the light, you can also vary the intensity of light from 0 to 100%. You can connect and control two loads simultaneously. It also has feature to connect virtual switch as potentiometer to vary the intensity of light in two way mode with respect to Smartphone.

7. PRODUCT FEATURES

- Works directly with AC power 100 - 240 V AC 50-60 Hz.
- Product firmware can be updated/reloaded/changed as per user requirement.
- Two Triac outputs, to control the lights.
- Triac output can handle up to 1 Amperes of current.
- WiFi with MQTT or HTTP protocol.
- A header is available on board to be used to connect Potentiometer/switch as virtual switch. It can be used as GPIO's. It can also be used for I2C communication by changing firmware of microcontroller.
- Basic Firmware to enter SSID and password to connect to the router
- Firmware has ability to control device through HTTP and MQTT mode.
- Push Button on board Provided for Restart and configuration Reset function.
- Does not require external neutral for output.
- It has bi colored namely Red and Green LED on board to indicate the status of the output.
- Product comes with wall mount plastic enclosure.

8. PRODUCT DESCRIPTION

a. PHYSICAL DESCRIPTION

- AC to DC Power supply module
- Triac 2Nos.
- Wifi Module
- Microcontroller

b. FUNCTIONAL DESCRIPTION

Block Diagram

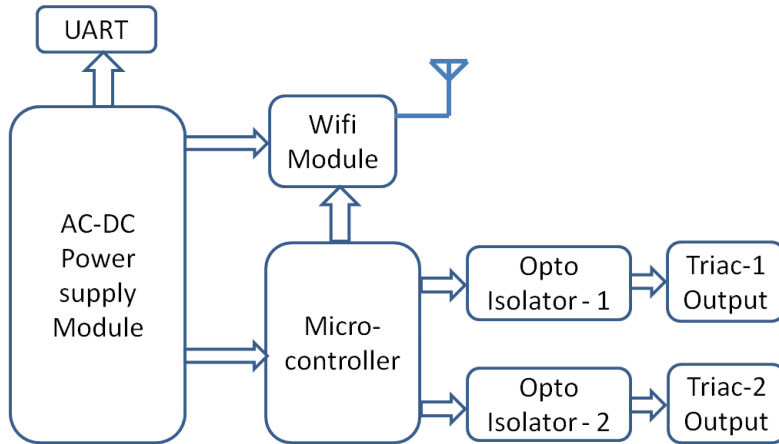

Figure 1: Block Diagram

Two Triac one Ampere board has an on-board power supply module which takes standard AC power as input and provides required DC power as output. The DC power is used to power-up microcontroller and Wifi module incorporated on board to run a dimmer algorithm and to establish Wifi communication with Smartphone respectively. There are two Triacs used to board to control ON/OFF and dimming of light intensity from a mobile application using MQTT/HTTP protocol. The board also has a bi-color LED to indicate the status of loads.

9. SYSTEM OVERVIEW

1. AC to DC Power supply module

AC to DC converter is power supply module manufactured from Hi-Link part number HLK-PM01. This power supply module rectifies and regulates voltage from 230 V AC to 5 V DC with output current capacity of 0.6A DC. The power of HLK-PM01 is at maximum of 3W. The 5V output can be accessed to connect any external sensors.

The DC-DC converter on board is used to regulate voltage from 5 V DC to 3.3 V DC to supply power to complete digital part.

2. Wifi Module

Wifi module used on the board is ESP12 with all its required GPIOs are easily accessible to user for their own application. Wifi module is powered by through 3.3 V DC. It works on both MQTT / HTTP protocol.

3. Zero Crossover Detection

Zero cross over detection is used to detect the zero crossing of AC phase to fire the Triac synchronously to get the smooth output. Optically isolated ZCD circuit is implemented to protect device from unwanted signals due to AC lines.

4. Triac

TRIAC is driven through optically isolated TRIAC drivers with reference to zero crossover detection. Synchronous switching method is used to regulate the power to loads. PWM signal will drive the TRIACs, and switches AC mains power from 0% to 100% of its total cycle. The PWM signal pulses can be configured in code with respect to AC mains frequency and voltage

level. BT136 Triac is used in this board to act as dimmer or switch.

5. Microcontroller

The Microcontroller executes the dimmer algorithm to drive the TRIAC switch, by receiving ZCD signal. Along with this, it has three LEDs to indicate the status of loads. Controller communicates with Wifi module through UART mode of communication to send and receive data to to-and-from respectively with connected Wifi network. ATmega328P microcontroller is used in the product to execute the algorithm, which is manufactured by Atmel incorporation and is compatible with Arduino.

Control processor has the capability for software up-gradation through Arduino and contains enough memory to upgrade and store the software for its own application.

10. TECHNICAL SPECIFICATION

a. ELECTRICAL SPECIFICATION

Input Specifications				
Description	Min	Typ	Max	Unit
Voltage AC	100	220	230	Volts
Current AC	0.6	2.6	-	Amps
Power AC	-	3	-	Watts
Frequency	50	-	60	Hz

Table 1: Input Specification

Triac-1 Output Specifications (Maximum)				
Description	Min	Typ	Max	Unit
Voltage AC	-	-	240	Volts
Current AC	-	-	1	Amps
Power AC	-	-	240	Watts

Table 2: Triac-1 Output Specification

Triac-2 Output Specifications (Maximum)				
Description	Min	Typ	Max	Unit
Voltage AC	-	-	240	Volts
Current AC	-	-	1	Amps
Power AC	-	-	240	Watts

Table 3: Triac-2 Output Specification

b. MECHANICAL SPECIFICATION

- Mechanical Dimensions of PCB are 70 x 50 x 20 mm (Length x Width x Height)
- Mounting Holes (M3) at distance of 4.5mm for edges of board

11. ELECTRICAL CONNECTIONS

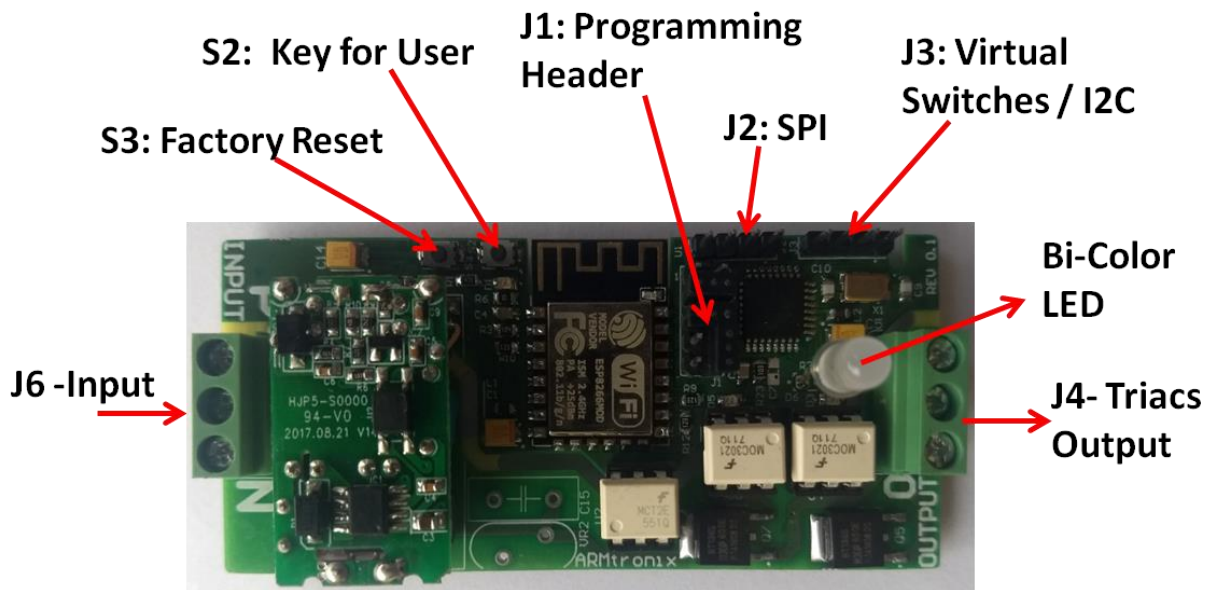

Figure 2: Header and Switch Details

Description of Header and Switches shown in Figure 2:

1. S2 Button is for Key for user
2. S3 Button is to reset the ESP
3. J1 UART programming header for both MCU and ESP.
4. J2 Header for Controller SPI Communication
5. J3 Header is for virtual switch and also compatible to I2C
6. J4 Output Terminal Block.
7. J6 Input terminal block



Figure 3: AC Input connection

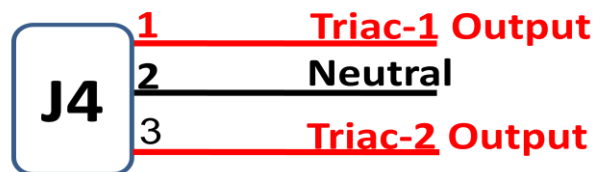

Figure 4: Triac pin-out

Figure 3, shows pinout and connection of AC Phase and Neutral connection to AC IN1 input connector. Figure 4, shows J1 output load connector.

Output: 1-Light, 1-Fan, Virtual Switch and Pot Wiring

Warning: These are 3.3V DC lines, NOT to bring in contact with AC lines

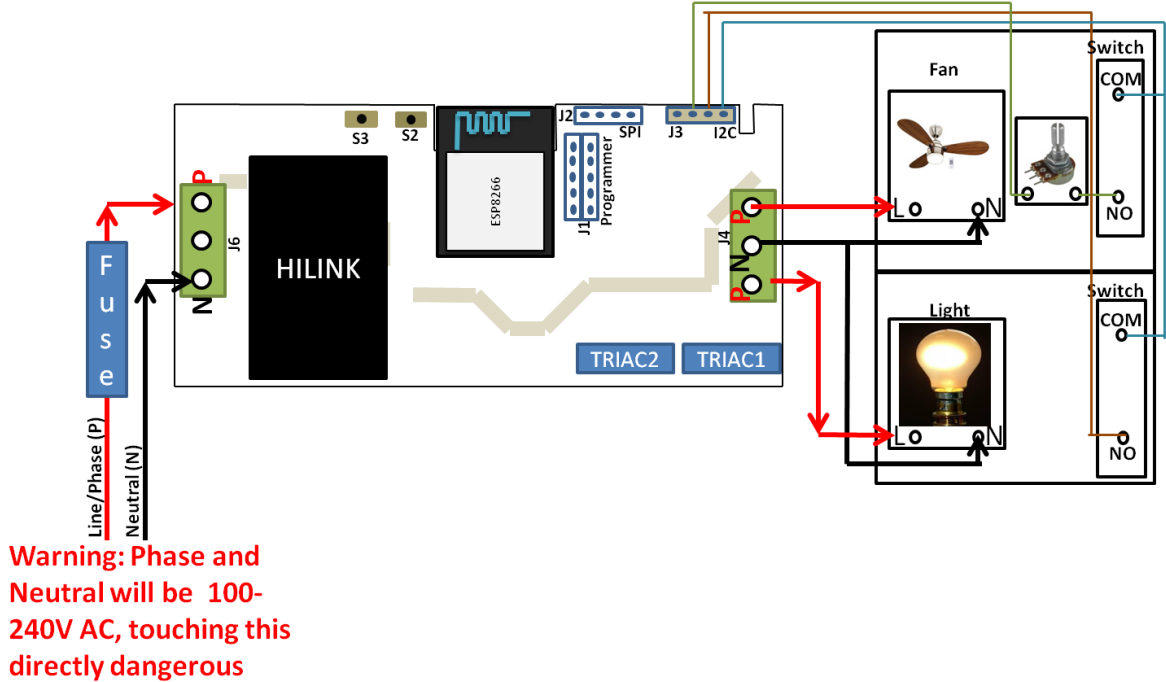

Figure 5: Load connection

Figure54 represents about connection between load and Triac output connector, along with virtual switch connections

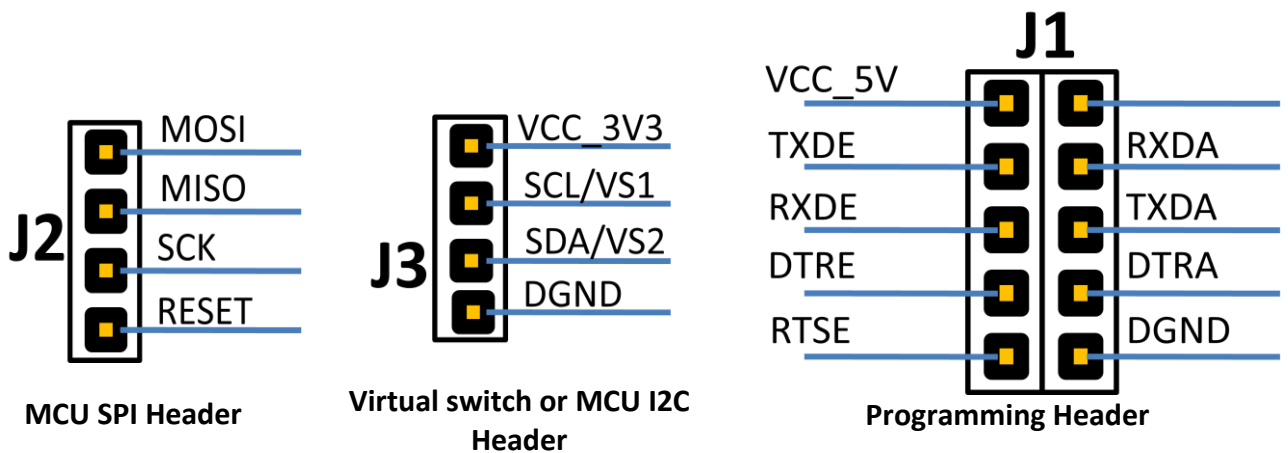

Figure 6: Other Header

Figure 6, shows the J1, J2 and J3 headers which Programming, MCU SPI header and Virtual switch or MCU I2C respectively. J2 and J3 can also be used GPIOs by modifying the MCU's firmware.

12. HOW TO USE THE PRODUCT

Power ON the device, so that, it will host the access point as shown in Figure 7,



Figure 7: Device hosting Access point

Connect the mobile to access point with Armtronix-(MAC ID). EX: Armtronix-1a-65-7 as shown in Figure 8.



Figure 8: Access point name

After connecting, open browser and enter 192.168.4.1 IP address, it will open the web server as shown in the Figure 9,

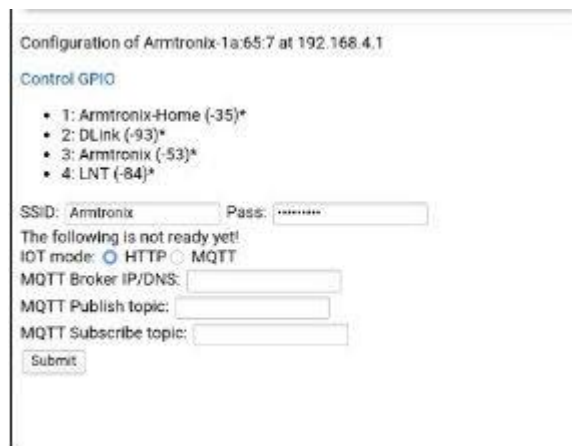

Figure 9: Web server

fill the SSID and password and select HTTP, if user wants to connect to MQTT then he has to select MQTT radio button, enter MQTT broker IP address, enter MQTT publish topic then MQTT subscribe topic and submit.

After submitting configuration, the ESP 8266 will connect to the router and router assigns IP address to the ESP. Open that IP address in the browser to control the switch (Relay).

Without configuring the SSID and Password we can control the Wifi Switch by connecting to the access point of the device and open the IP address of device i.e 192.168.4.1 the web server page will show the link with the name Control GPIO as shown in the Figure 8, by clicking this link we can control the Wifi Switch board but the response will be slow.

13. HOW TO CUSTOMISE FIRMWARE

You can program this board using Arduino IDE. Please follow the below steps to program the board by yourself with easy steps as mentioned below:

a. STEPS TO LOAD PROGRAM TO ESP8266:

1. Use external USB-UART converter between computer and this board.
2. Connect VCC of converter to "Pin-1.VCC_5V" of J1.
3. Connect RX pin of converter to "Pin-3.TXDE" of J1.
4. Connect TX pin of converter to "Pin-5.RXDE" of J1.
5. Connect DTR pin of converter to "Pin-7.DTRE" of J1.
6. Connect RTS pin of converter to "Pin-9.RTSE" of J1.
7. Connect GND of converter to "Pin-10.DGND" of J1.
8. Open your code in Arduino IDE as shown.
9. Click on Tools Tab, move mouse pointer on "Board: xxxxxxxxxxx" and click on "NodeMCU0.9 (ESP-12 Module)" as shown in figure 10.

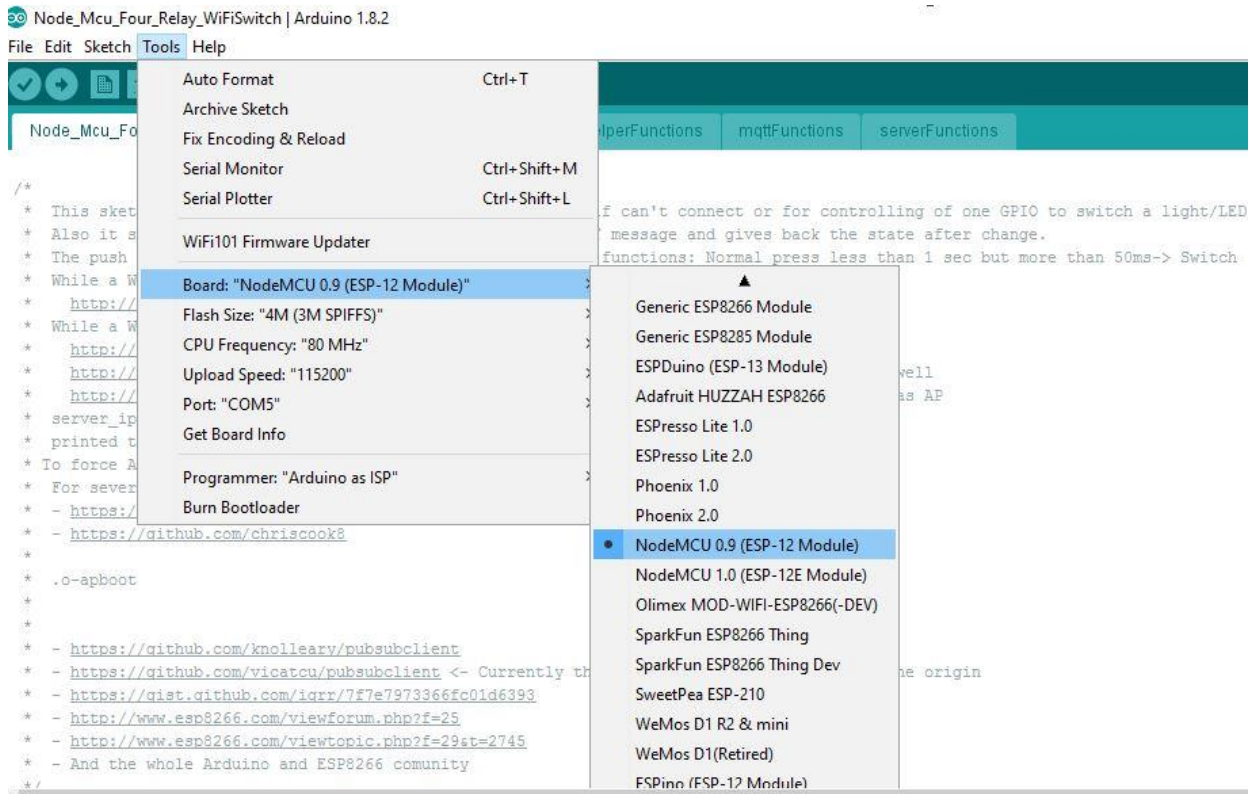

Figure 10: Board Selection

10. Click on tools tab, move mouse pointer to “Programmer: “Arduino as ISP””, under this click on “Arduino as ISP” to select. Refer to figure 11.

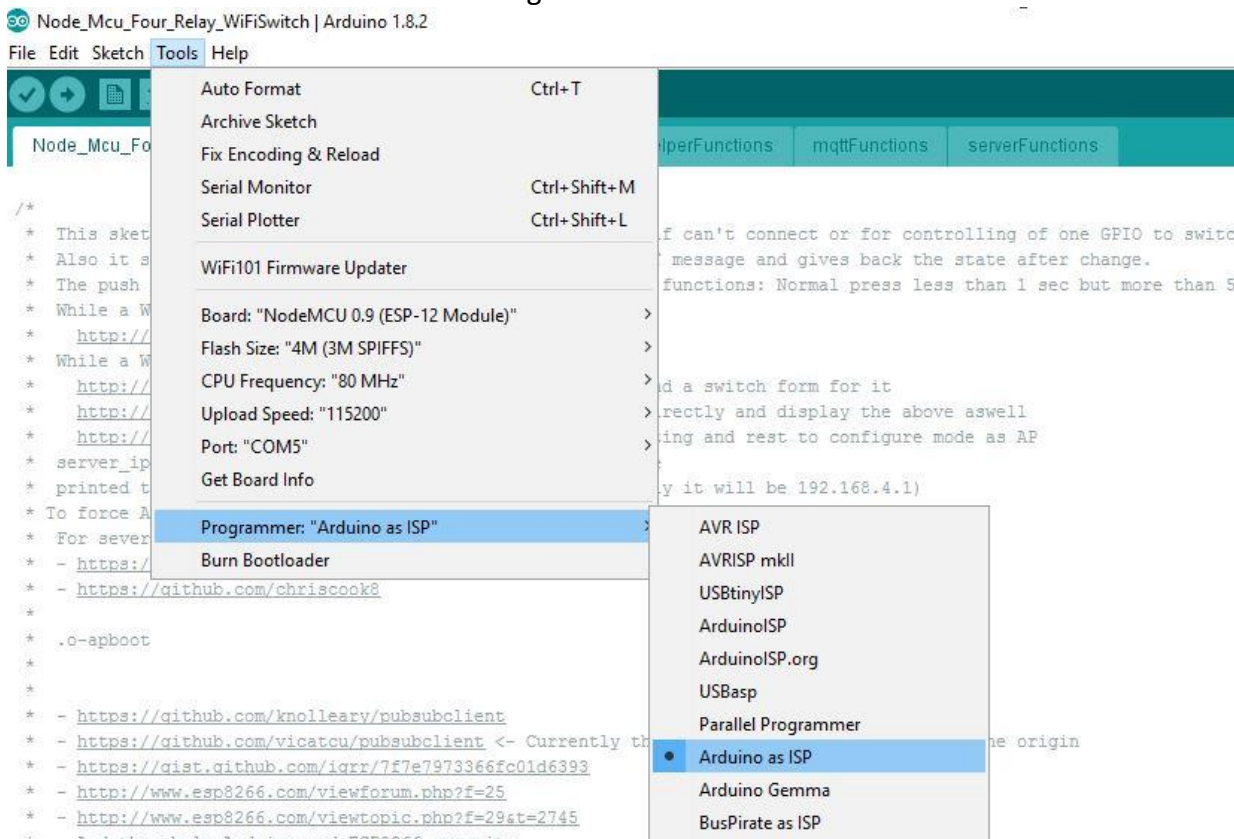

Figure 11: IDE Selection

11. Click on tools tab, move mouse pointer to “Port: “COMx”, under this click on “COMx” to select. (“x” refers to port number available in your computer) Refer to figure 12.

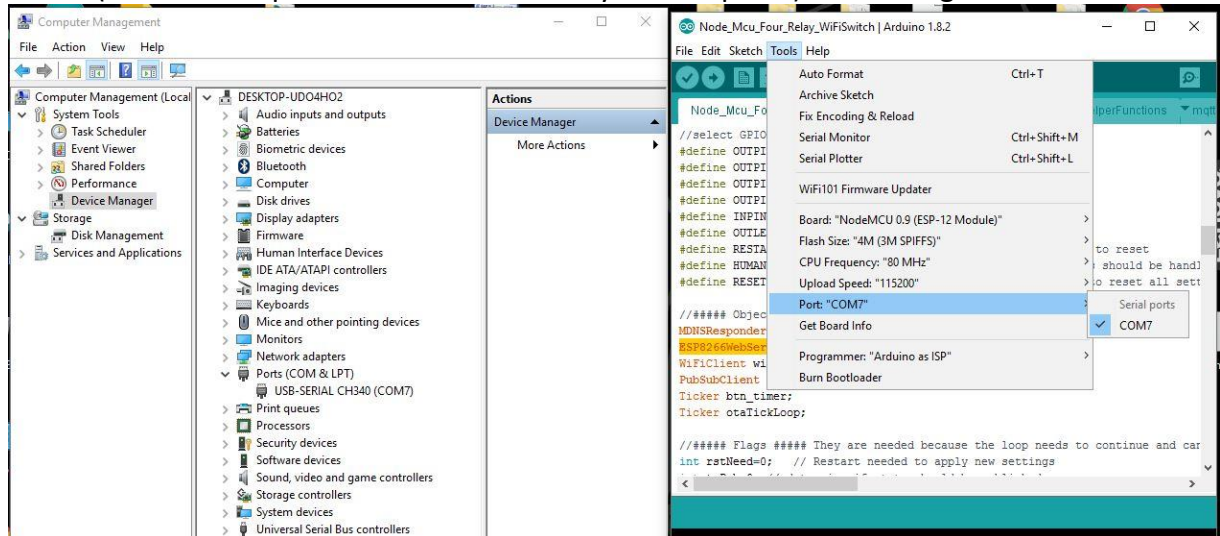

Figure 12: COM port selection.

12. Run the program. Refer to Figure 13.

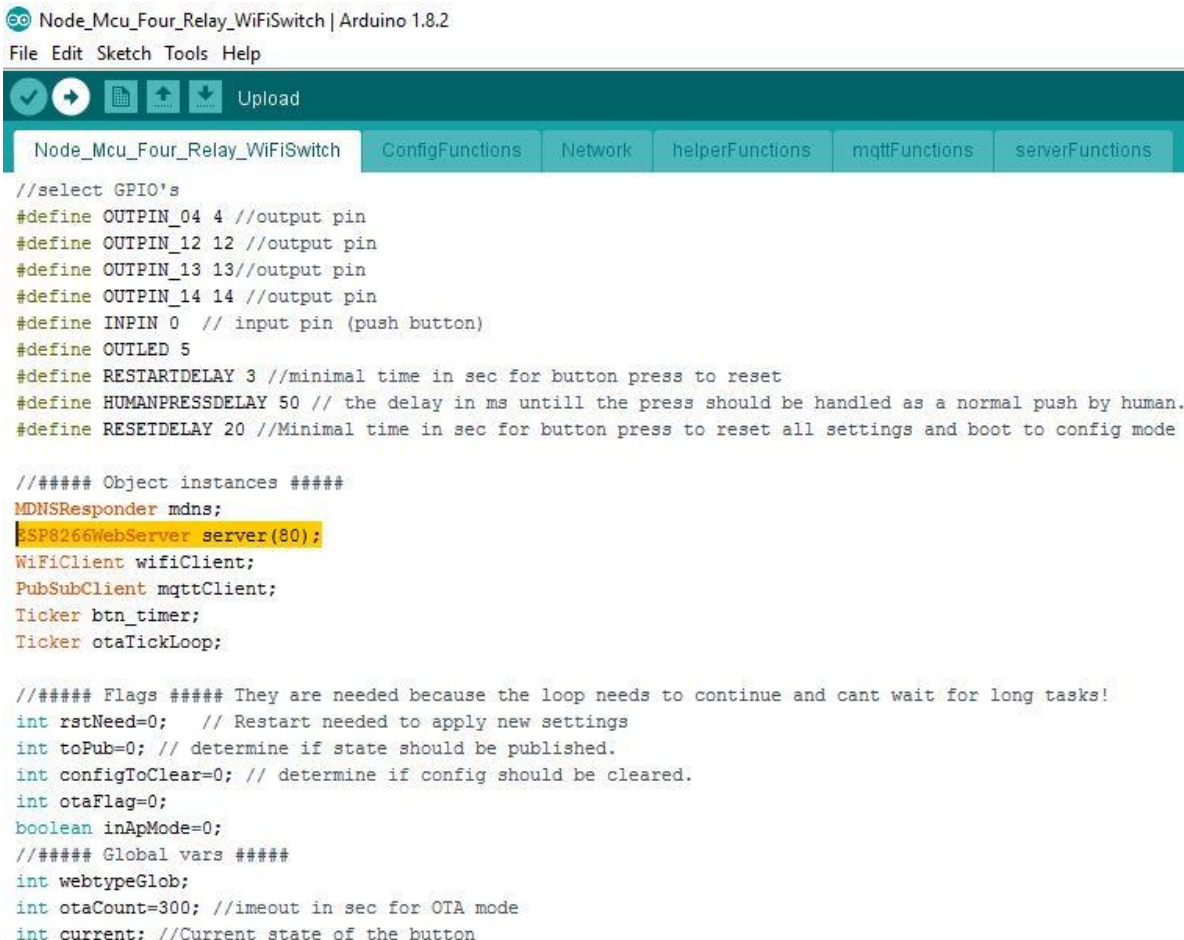

Figure 13: Executing code

b. STEPS TO LOAD PROGRAM TO ATMEGA328P:

1. Use external USB-UART converter between computer and this board.
2. Connect VCC of converter to "Pin-1.VCC_5V" of J1.
3. Connect TX pin of converter to "Pin-4.RXDA" of J1.
4. Connect RX pin of converter to "Pin-6.TXDA" of J1.
5. Connect DTR pin of converter to "Pin-8.DTRA" of J1.
6. Connect GND of converter to "Pin-10.DGND" of J1.
7. Follow same steps as shown in section from "13.a Steps to Load Program to ESP8266", except Step 10. In step 2, you need to select "Arduino Uno" instead of "NodeMCU0.9 (ESP-12 Module)". Follow the remaining steps as they are.

Once your loading of program is completed, disconnect converter from board and short Pin-3.TXDE to Pin-4.RXDA, short Pin-5.RXDE to Pin-6.TXDA, to check the board functionality and use. If the board is working as per your code, then you can install it for your application.



DOCUMENT #: BA001

DOCUMENT REV: 0.1

DOCUMENT NAME: DESIGN DESCRIPTION, Wifi DUAL DIMMER 1A Board.

IMPORTANT NOTICE

ARMtronix Technologies LLP and its subsidiaries reserve the right to make corrections, enhancements, improvements and other changes to its products and services and to discontinue any product or service. Buyers should obtain the latest relevant information before placing orders and should verify that such information is current and complete. All products are sold subject to ARMtronix Technologies LLPs terms and conditions of sale supplied at the time of order acknowledgment.

The information in this document is subject to update without notice. The contents of this document thereof must not be used for any unauthorized purpose.

-----END OF DOCUMENT-----